

CONTENTS

- OPERATING SYSTEM OF SHOTGUN
- GENERAL SAFETY RULES
- MANUAL SAFETY
- ASSEMBLY
- ASSEMBLY OF STOCK AND BARREL
- ASSEMBLY OF STOCK AND BARREL TO THE FRAME
- DISASSEMBLY OF LIMITTER
- LOADING-SHOTGUN
- LOADING CARTRIDGE TO THE MAGAZINE
- INSERTING CARTRIDGE TO THE BARREL CHAMBER
- UNLOADING OF SHOTGUN
- REMOVING CARTRIDGE FROM THE BARREL
- DISSASEMBLY OF MC 312 SHOTGUN FOR CLEANING AND MAINTANENCE
 - PULLING BACK THE MECHANISM AND FIXING
 - DISSASEMBLY OF BARREL
 - REMOVING THE MECHANISM
 - REMOVING THE TRIGGER
- USAGE OF SUITABLE CARTRIDGE
- CONTINUED SAFETY MANUAL WARNINGS IN ADDITION TO THE MANUAL
- SAFETY MEASURES
- SAFETY WARNINGS
- LEGAL NOTICE

TECHNICAL SPECIFICATIONS

TECHNICAL SPECIFICATION	MC 312
Action	SEMI-AUTO Inertial Rotary System
Gauge	12
Chamber	76 (3")
Barrel Length	51, 55, 61, 66, 71, 76 cm
Barrel	Chrome Coating
Magazine Capacity	(2+1),(3+1),(4+1), (5+1) (5+1 is not possible for the magnum style cartridges)
Recoil Pad	Ergonomic Rubber
Safety	Manual, Reversible Safety Button
Weight (For 12 Gauge)	2950-3200 gr
Stock and Forend	Synthetic and Walnut
Chokes	Mobile Choke System (1-2-3-4-5)
Locking System	Rotating Bolt With Reinforced Lugs
Receiver	Aluminium-Alloy Receiver
Trigger	Nickel, Chrome, Black Oxid
Front Sight	Special Phosphored

NOTE : Camouflage coating is optional according to the customers desires.

OPERATING SYSTEM OF SHOTGUN

MC 312 semi-automatic shotgun operates with the kinetic recoil (inertia) energy. This recoil energy completes the cycle of the action. This operating system is based on the rotary head which is located inside the mechanism.

MC 312 does not need any gas pressure and any action of barrel. Therefore, lost of pressure comes down to zero. It provides you more effective shooting to far distance than other shotguns.

MC 312 ISO 9001:2000 is manufactured according to international quality Standards and TS 870 Turkish standard.

PERFECT



GİRSAN

GENERAL SAFETY RULES

Please read safety information before use of MC 312 semi-automatic shotgun. Because of wrong usage of safety rules MC 312 semi-automatic shotgun that may cause death and injury.

Read the instructions and warnings in this manual CAREFULLY BEFORE using this shotgun.

Failure to read these instructions and to follow these warnings may result in serious injury or death of you and others and damage to property

NOTICE : NEVER DIRECT YOUR MC 312 SEMI-AUTOMATIC SHOTGUN TO AN UNSAFE DIRECTION

Make sure that there is no alive behind the shooting point while you are shooting any point.

Do not direct anywhere your shotgun's barrel without control of shot point.



NOTICE : ACT LIKE YOUR MC 312 SHOTGUN IS LOADED EVERYTIME

For your safety and the safety of others, it is imperative that you keep your shotgun locked and unloaded in a secure way. If you take shotgun to your hand, certainly control that if the cartridge is in chamber or not. If you charging or discharging the cartridge, make sure that your shotguns Barrel is on a safe direction.,

NOTICE : KEEP YOUR MC 312 SHOTGUN FAR AWAY FROM CHILDREN

Keep your shotgun empty and keep ammunition far away from it. Keep your shotgun where children can not reach. You must always keep your firearm and ammunition separately so that they are not accessible to children and/or other unauthorized persons.

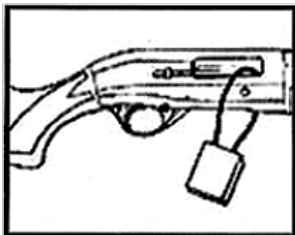

NOTICE : BEWARE OF BARREL OBSTRUCTIONS

Be sure the barrel is clear of obstructions before shooting. Mud, water, snow or other objects may inadvertently lodge in the barrel bore. A small obstruction can cause a dangerous increase in pressure and may damage your gun and cause injury to yourself and others. When you shoot hard ground or water so possibility of hopping and disruption is very high. This situation can give damage to alive without your object.



NOTICE : ALWAYS USE THE CORRECT AMMUNITION FOR YOUR PARTICULAR MC 312 SHOTGUN

Prefer cartridges which are suitable according to CIP or SAAMI standards.

NOTICE : ALWAYS WEAR EYES AND EAR PROTECTORS THAT ARE SPECIFIED FOR USE WITH SHOTGUN

Use shooting glasses and ear protectors while shooting.



NOTICE : NEVER TRANSPORT WITH A LOADED SHOTGUN

When transporting your firearm, be sure it is unloaded and locked. Safe and secure transportation of your shotgun is your responsibility. Do not forget to discharge your shotgun while you are passing from any barrier.



NOTICE : NEVER USE ALCOHOL OR DRUGS BEFORE OR WHILE SHOOTING.

Do not use your firearm if you are on any medication which impairs, even slightly, your mental or physical ability.

Do not forget if you use any alcohol ,any medicine when you use shotgun you can damage someone around you.



NOTICE : MAKE SURE THE SHOTGUN IS UNLOADED BEFORE GET ON VEHICLE

Before you get on any vehicle ,keep your shotgun locked and unloaded in secure..Please full your shotgun in only shooting area.



NOTICE : DO YOUR SHOTGUN'S MAINTENANCE REGULARLY.

After using your shotgun ,do your shotgun's maintenance and baste all required part of gun regularly according to user manual correctly .Please be sure there is not any pieces in the barrel like stone, cartridge's powder ,dirty ,snow.



NOTICE : OBEY THE SAFETY RULES

Use your shotgun suitable with carriage rules and conservation.

MANUAL SAFETY

MC 312 semi- auto shotgun has a manual safety lever which can be pushed from left to right to make the safety on. (safe position). When the safety latch is pushed from right to the left the manual safety will be off and the shotgun will be ready to shoot. A red sign will be appeared on the manual safety latch when the safety is off. (ready to shoot).



ASSEMBLY

NOTE : Make sure that safety lever is on while making the assembly.

ASSEMBLY OF STOCK AND BARREL

Remove fore-arm screw by turning to the counter clock wise end then remove fore-arm by pulling below it.



Fore-arm's tip is based on barrel and placed to circle of barrel slowly.



ASSEMBLY OF STOCK AND BARREL TO THE FRAME

Held fore-arm and Barrel and then pass over of magazine then push the Barrel heading to inside of body until to be disappear .End then set fore-arm screw.



DISASSEMBLY OF LIMITER

The limiter, limits the shotgun's capacity until two cartridges, if you want to remove it first you should remove fore-arm screw and then you can take limiter outside.



LOADING

LOADING CARTRIDGE TO THE MAGAZINE

First of all select the suitable cartridge according to your aim (hunting or target shooting, etc...) and then push the cartridge inside of magazine with your thumb until to be disappear.



INSERTING CARTRIDGE TO THE BARREL CHAMBER

First make sure that the shotgun safety is on. (safe position) After loading the magazine, press the trigger group lever. Make sure that if the cartridge fall into the cartridge's spoon .Pull the mechanism bolt handle to the end then release it. Now your shotgun is ready to shoot. When you feel ready, please push the safety lever to make the safety off and then shoot.

UNLOADING

REMOVING CARTRIDGE FROM THE BARREL

Make sure that your safety lever is on. (safe position) pull the mechanism back to the end, the cartridge will be removed from the barrel chamber.

UNLOADING THE CARTRIDGE FROM THE MAGAZINE

Make sure that your shotgun is at safety position. Pull the mechanism back to the end while pressing trigger group lever and then leave it. Repeat this action until discharge of magazine. The mechanism will stop at the back when all the cartridges are removed from the magazine.

DISSASSEMBLY MC 312 SHOTGUN FOR CLEANING AND MAINTANENCE

PULLING BACK THE MECHANISM AND FIXING

Press trigger group lever. Pull the mechanism fully back and fix it.

DISSASSEMBLY OF BARREL

Remove the fore-arm screw by turning to the clock wise end then remove fore-arm by pulling below it. Hold the shotgun with your right hand and hold the body by left hand then Barrel and fore-arm is hold together then remove the barrel and fore-arm together by pushing back .

REMOVING THE MECHANISM

Make sure that the mechanism is not fixed at the back. If it is fixed, pull the bolt handle and release it forward position slowly. Take out both handle by pulling it out. Take out the mechanism by turning the barrel below. Be careful do not fall the mechanism.



REMOVING THE TRIGGER GROUP

First pull the frame fixing pin with an another pin and then take it out. And then take the trigger group out by pulling the trigger group lever.



USAGE OF CORRECT CARTRIDGE

MC 312 is a semi-automatic, 12 caliber (3 inch) shotgun. MC 312 shotgun can be operated with the cartridges between 24 to 54 gram. If you produce own your cartridges, please obey all the international standards. Otherwise Our company will not be responsible because of wrong charging and bad ammunition.

MC 312

EXPLODED DRAWINGS

SHOTGUN ASSEMBLY

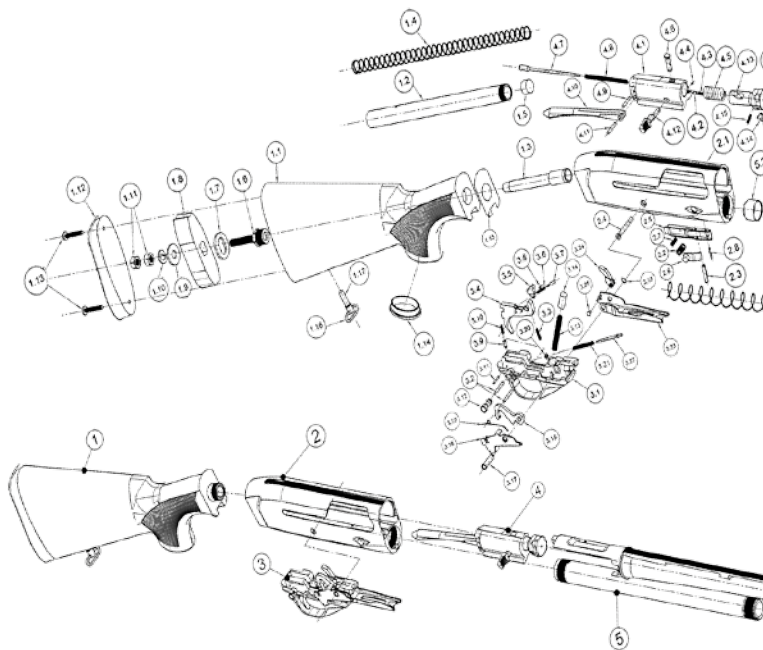

SHOTGUN ASSEMBLY

1-STOCK GROUP

- 1.1-STOCK (Y0312110000)
- 1.2-RECOIL SPRING GUIDE (Y0312112000)
- 1.3-RECOIL SPRING WEIGHT (Y0312114000)
- 1.4-RECOIL SPRING (Y0312118000)
- 1.5-SHOCK ABSORBER (Y0312118000)
- 1.6-SCREW (Y0312120000)
- 1.7-OVAL WASHER (Y0312122000)
- 1.8-STOCK SKID (Y0312124000)
- 1.9-WASHER (Y0312126000)
- 1.10-RONDELA (Y0312128000)
- 1.11-NUT (Y0312130000)
- 1.12-PAD(RUBBER) (Y0312132000)
- 1.13-PAD SCREW (Y0312134000)
- 1.14-ROSETTE (Y0312136000)
- 1.15-STOCK ADJUSTING PART (Y0312138000)
- 1.16-BELT HOLDER (Y0312142000)
- 1.17-BELT HOLDER PIN (Y0312144000)

2-FRAME GROUP

- 2.1-FRAME (Y0312310000)
- 2.2-FRAME SHEET SPRING (Y0312312000)
- 2.3-FRAME SHEET PIN (Y0312314000)
- 2.4-FRAME ASSEMBLY PIN (Y0312316000)
- 2.5-FRAME SHEET METAL BUSHING (Y0312322000)
- 2.6-FRAME SHEET METAL BUSHING (Y0312324000)
- 2.7-FRAME SHEET METAL BUSHING SPRING (Y0312326000)
- 2.8-FRAME SHEET METAL PIN (Y0312328000)

3-TRIGGER GROUP

- 3.1-TRIGGER GUARD (Y0312710000)
- 3.2-TRIGGER PIN (Y0312712000)
- 3.3-TRIGGER SPRING (Y0312714000)
- 3.4-TRIGGER (Y0312716000)
- 3.5-HAMMER HOLDER (Y0312718000)
- 3.6-HAMMER HOLDER SPRING (Y0312720000)
- 3.7-HAMMER HOLDER SPRING PIN (Y0312722000)
- 3.8-HAMMER HOLDER SPRING PIN (Y0312724000)
- 3.9-SAFETY SPRING PIN (Y0312726000)
- 3.10-SAFETY SPRING (Y0312728000)
- 3.11-SAFETY SPRING SUPPORT PIN (Y0312730000)
- 3.12-TRIGGER SAFETY BUTTON (Y0312732000)
- 3.13-HAMMER PISTON SPRING (Y0312734000)
- 3.14-HAMMER PISTON (Y0312736000)
- 3.15-HAMMER (Y0312738000)
- 3.16-TRIGGER GUARD INSERT SHEET (Y0312740000)
- 3.17-HAMMER PIN (Y0312742000)
- 3.18-HAMMER PIN RING (Y0312744000)
- 3.19-TRIGGER GUARD INSERT SHEET (Y0312746000)
- 3.20-SPECIAL STAMP (Y0312748000)
- 3.21-BULLET ELEVATOR SPRING (Y0312750000)
- 3.22-BULLET ELEVATOR SPRING PIN (Y0312752000)
- 3.23-BULLET SPOON (Y0312762000)
- 3.24-BULLET ELEVATOR (Y0312764000)
- 3.25-BULLET ELEVATOR PIN (Y0312766000)

SHOTGUN ASSEMBLY

4-MECHANISM GROUP

- 4.1-MECHANISM (Y0312410000)
- 4.2-PISTON (Y0312412000)
- 4.3-MECHANISMS LEVER PIN SPRING (Y0312414000)
- 4.4-MECHANISM LEVER PIN (Y0312416000)
- 4.5-ROTARY HEAD SPRING (Y0312418000)
- 4.6-ROTARY (BOLT) HEAD PIN (Y031242000)
- 4.7-FIRING (Y0312422000)
- 4.8-FIRING PIN SPRING (Y0312424000)
- 4.9-FIRING PIN SUPPORT PIN (Y031228000)
- 4.10-MECHANISM SUPPORT (Y0312428000)
- 4.11-MECHANISM SUPPORT PIN (Y0312430000)
- 4.12-MECHANISM LEVER (Y0312432000)
- 4.13-ROTARY HEAD (Y0312442000)
- 4.14-EXTRACTOR (Y0312444000)
- 4.15-ROTARY HEAD EXTRACTOR SPRING (Y0312446000)
- 4.16-EXTRACTOR (Y0312448000)

5-MAGAZINE GROUP

- 5.1-MAGAZINE TUBE (Y0312610000)
- 5.2-MAGAZINE SPRING BUSHING (Y0312612000)
- 5.3-MAGAZINE SPRING (Y0312614000)
- 5.4-MAGAZINE RING (Y0312616000)
- 5.5-LIMITTER (Y0312618000)

6-BARREL GROUP

- 6.1-BARREL BUSHING (Y0312510000)
- 6.2-CARTRIDGE LAUNCHER PISTON (Y0312512000)
- 6.3-CARTRIDGE LAUNCHER (Y0312514000)
- 6.4-CARTRIDGE LAUNCHER SPRING (Y0312516000)
- 6.5-CARTRIDGE LAUNCHER PIN (Y0312518000)
- 6.6-SIGHT (Y0312520000)
- 6.7-MOBIL SHOCK (Y0312522000)
- 6.8-BARREL (Y0312532000)
- 6.9-BARREL RIB (Y0312540000)
- 6.10-BARREL HOLDER (Y0312542000)
- 4.2- BARREL HOLDER PISTON (Y0312412000)
- 4.3-MECHANUM LEVER PIN SPRING (Y0312414000)

7-FOREND GROUP

- 7.1-FOREND GROUP (Y0312210000)
- 7.2-THICK STAMP (Y0312212000)
- 7.3-SPRING RING (Y0312214000)
- 7.4-FOREND RING (Y0312216000)
- 7.5-FOREND SCREW (Y0312222000)
- 7.6-FOREND BELT STAMP
- 7.7-FOREND BELT SCREW (Y0312226000)
- 7.8-BELT PIN (Y0312232000)
- 7.9-FOREND BELT (Y0312234000)

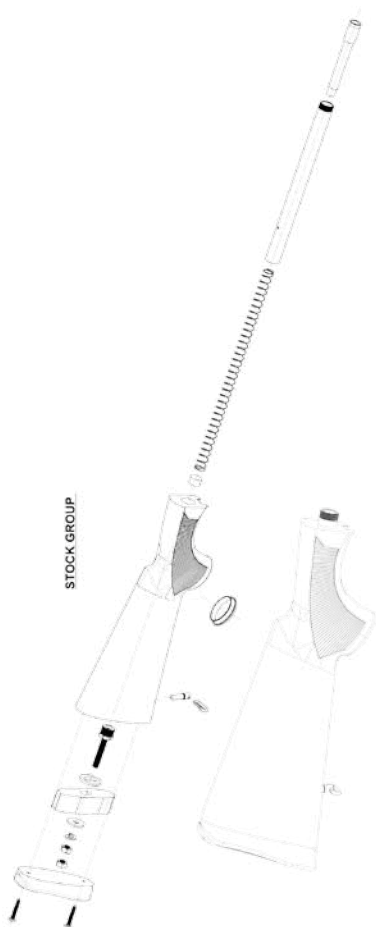

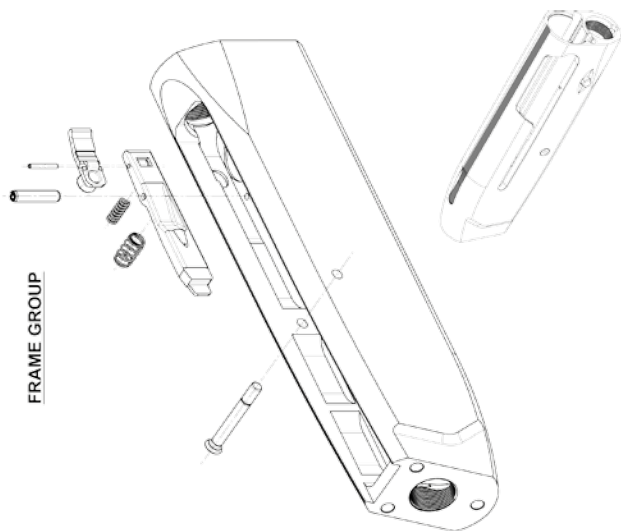

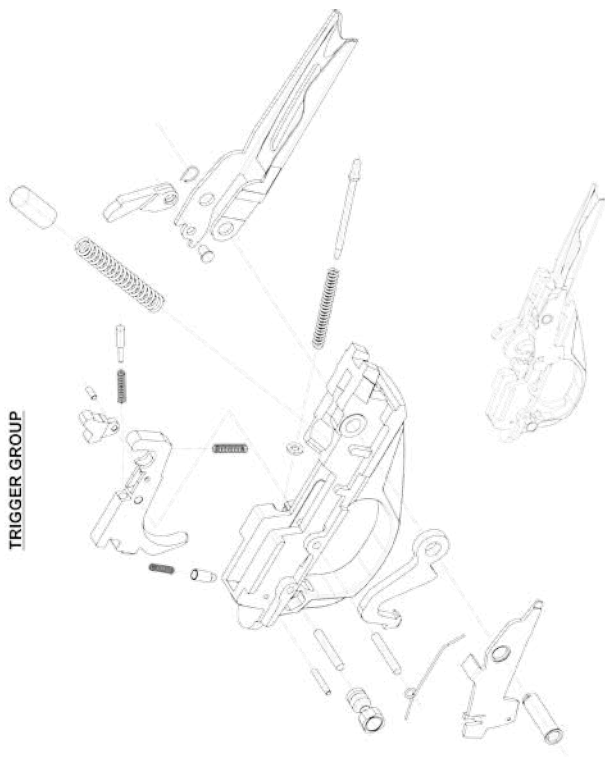

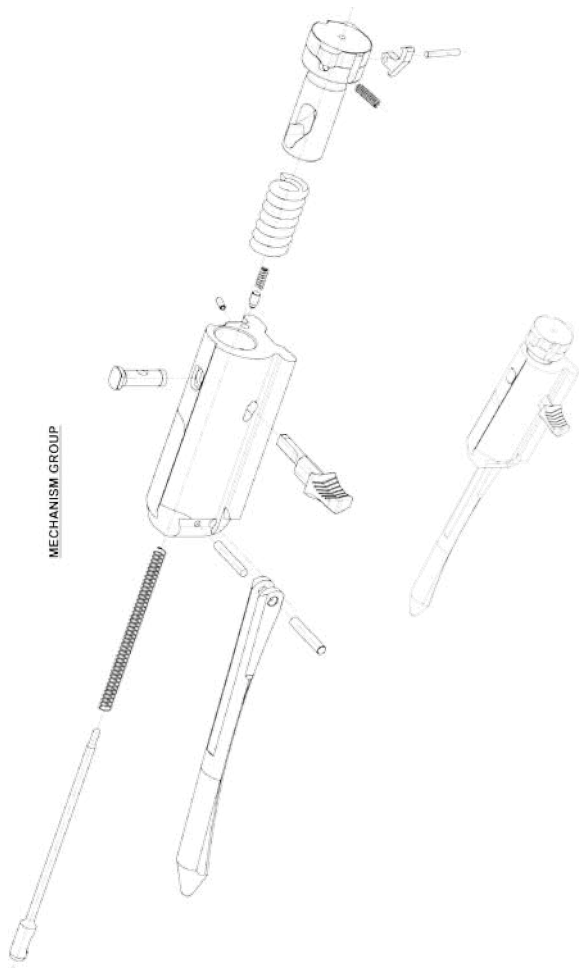

MAGAZINE GROUP

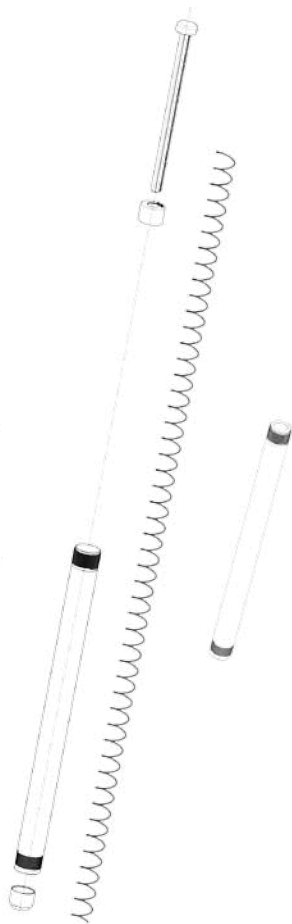

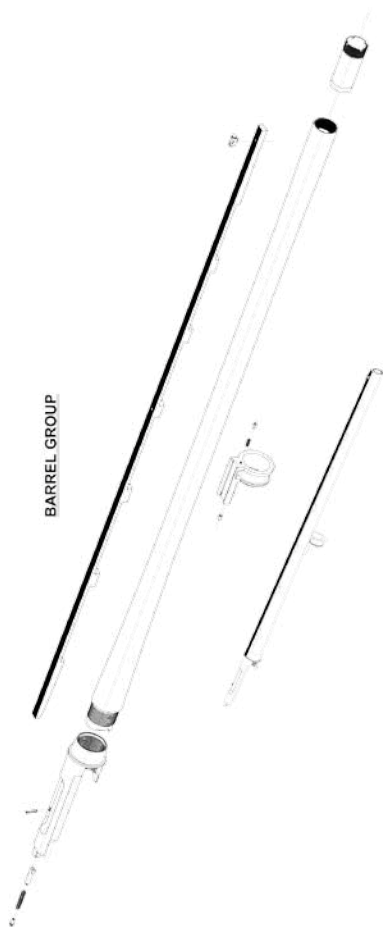

FOREND GROUP

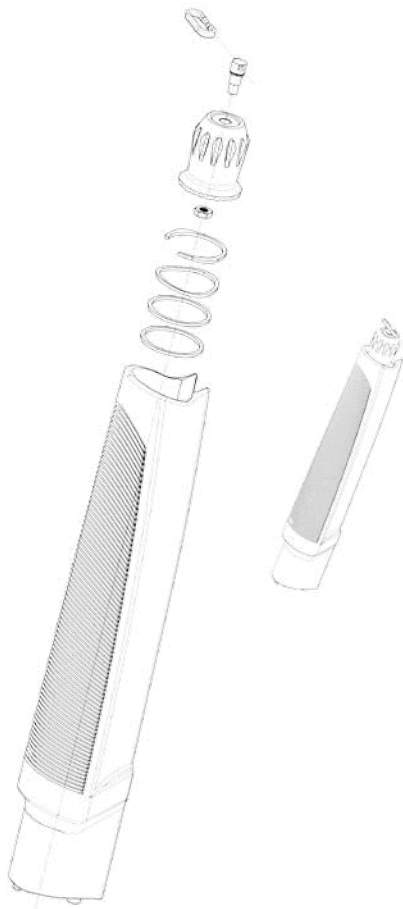

**Continued Safety
Manual Warnings
in addition to the manual.**

Girsan Shotgun

SAFETY MEASURES: Put check mark next to each warning and safety measure when understood.

- Always point the firearm in a safe direction even though it may be unloaded. Do not point the gun at anything you do not intend to shoot. Never ever hor-replay while handling a gun.
- Keep your finger away from the trigger when operating any other part of the gun's mechanism.
- Keep the safety "ON" until you are actually ready to fire. Treat gun with caution and always point in a safe direction.
- Keep your fingers away from the muzzle. Never pull a gun toward you by the muzzle.
- Be sure the barrel is clear of obstructions never assume, always check.
- Keep your gun unloaded when not in use.
- Always aim at a safe target, taking care that it does not conceal any other object. Be sure of your target and what lies behind, beyond, or near before you pull the trigger. Never shoot at sounds. To avoid ricochets, do not shoot at a flat, hard surface, curved surface, or at water.
- Store guns and ammunition separately, prevent access by children and others. Must be under lock and key. Guns should always be unloaded when stored.
- Never carry a loaded gun inside a vehicle, house, camp, or public place. When transporting the gun keep the gun "on safe" and unloaded. Never climb a tree or fence, or jump a ditch with a loaded gun.
- Never rely on any anyone's words that the gun is "on safe" or unloaded. Always check to see if the gun is "on safe" and unloaded when getting it from another person or storage.
- Never drink alcoholic beverages or use drugs before handling firearms or during shooting.
- Always use eye & hearing protection and make sure bystanders are also similarly protected.
- Although the firearm itself does not contain any lead, it fires ammunition containing lead or lead compounds, which are

known to be dangerous to your health. Take protective health measures when shooting or when cleaning firearms. Avoid exposure to the lead while handling and wash your hands after contact. Proper air ventilation is absolutely necessary when shooting indoors or cleaning the firearm.

- Use proper ammo type only, malfunction, injury, or death will result from the use of faulty, incorrect type, size, gauge, non-standard, re manufactured, hand loaded, reloaded ammunition, old ammunition, or damaged ammunition. Because of the poor or non existent quality control of companies or people, overloads and underloads may occur. Following safety rules will save your life or the life of someone else.
- Know the range of your ammunition, All ammunition may have a range up to 5 miles or more. Absolutely never shoot up into the air. Always know what lies behind, beyond, or near before shooting.



SAFETY WARNINGS

FIREARMS ARE DANGEROUS WEAPONS, WHICH CAN CAUSE SERIOUS INJURY OR

DEATH. WHEN USING ANY FIREARM, SAFETY MUST BE YOUR FIRST AND ONLY

CONCERN. FIREARM SAFETY IS YOUR SOLE RESPONSIBILITY.

Always keep this manual with your firearm. Make sure you understand all the operational instructions, safety procedures and warnings in this manual before you handle the firearm. If there's anything you don't understand, do not handle firearm, and write to us. If you sell, lend or give the firearm to another, make sure this manual goes with firearm. Obtain free firearm manual from Buds Police Supply.

ALWAYS TREAT YOUR FIREARM AS IF IT WERE LOADED. Always point the barrel in a safe direction! Use the manual safety button as outlined in this manual. Never move the safety to "FIRE" position until you are ready to fire. Never point a firearm at or near somebody else even if it's unloaded.

USE ONLY THE CORRECT AMMUNITION FOR YOUR FIREARM.

Use only the correct caliber and length ammunition for your pistol. Use factory made load of normal pressure.

MAINTAIN YOUR FIREARM.

Keep the barrel clean and free of obstructions. Clean your firearm regularly and have it inspected periodically to make sure it is mechanically correct and functioning properly. Worn or damaged parts are dangerous.

The owner is fully responsible to keep this firearm cleaned and maintained with routine checkups with qualified gunsmiths.

NEVER TOTALLY DEPEND ON A MECHANICAL SAFETY.

It is not a substitute for proper gun handling. Like all mechanical devices like safety are subject to breakage or malfunction from wear or abuse or dirt or corrosion or user did not fully engage safety or repair, or lack of maintenance or any combinations of factors beyond the control of manufacturer. Manufacturer has made these firearms with the highest quality materials and workmanship and safety is the sole responsibility of the owner.

NO MECHANICAL SAFETY IS "CHILDPROOF" OR "FOOLPROOF".

No safety ever invented can be relied upon to prevent an accidental shooting by a determined child or a grownup idiot "playing" with a gun.

TREAT EVERY GUN AS IF YOU EXPECT ITS MECHANICAL SAFETY NOT TO WORK.

You will be Astounded at how cautious.

Always keep the safety on the "ON" position until you are ready to fire and the muzzle is pointing at the target.

Make sure that you understand how all controls work before you attempt to load the firearm.

Keep the muzzle pointed in a safe direction and your finger off the trigger when operating the safety. Malfunctions which may cause a gun to fire when safety is engaged or disengaged are rare but can happen. Even if an accidental firing should occur, nobody will be hurt if you follow this rule. You must follow this rule.

WARNING! THREE THINGS
TO REMEMBER ABOUT
SAFETIES



1. NEVER TOTALLY DEPEND ON A MECHANICAL SAFETY. It is not a substitute for proper gun handling. Like all mechanical devices, a safety is subject to breakage and malfunction from wear or abuse or dirt or corrosion or user did not fully engage safety or repair, or lack of maintenance or any combinations of factors beyond the control of the manufacturer. Manufacturer has made these firearms with the highest quality materials and workmanship and safety is the sole responsibility of the owner.
2. No mechanical safety is "child-proof" or "foolproof". No safety ever invented can be relied upon to prevent accidental shooting by a determined child or grown up idiot "playing" with a gun.
3. Treat every gun as if you expect the mechanical safety to not work. You will be astounded at how cautious you become and how little tolerance you will have for the complacency of others.

Never attempt to load or unload any firearm inside a vehicle, building or other confined space (except a properly constructed shooting range). Enclosed areas offer no completely safe direction in which to point the firearm because you don't know what is behind the walls. When hunting in the fields or woods constantly monitor where everybody is. Properly position yourselves, don't let other shooters get behind you or in front of you or out of your view, creating a deadly situation. As always, point in a safe direction. Always keep the safety on the "ON" position until you are ready to fire and the muzzle is pointing at the target.

When shooting, full eye and ear protection is mandatory at all times. Shooters and spectators must wear shooting glasses and sound suppressor to prevent eye injury and hearing loss. Vision loss and hearing impairment can occur with only one moment of non-protection.

**WARNING! LEAD EXPOSURE:**

The actual firearm does not contain any lead, however it can fire ammunition containing lead, or lead compounds, known to the state of California to cause cancer, birth defects, reproductive harm, and other serious injury. Those who discharge a firearm stand near someone who fires or cleans firearms are hereby warned of the dangers presented by lead or lead compounds. Take protective health measures, avoid indoor shooting ranges. Clean firearms outdoors. Wear gloves, wash hands, etc.

WARNING! Barrel Obstructions:

BEFORE LOADING or firing a firearm, examine the bore and the firing chamber to be certain they are clean and free of any obstruction. Even a heavy coat of oil, grease, snow or water may result in damage to the firearm and injury to the shooter and/or persons near the firearm. A misfire or unusual sound upon firing is a signal to cease firing and to examine the chamber and bore. If there is any obstruction, clear the obstruction and clean

the bore and chamber before firing.

**WARNING! LIMITED VIEW:**

Always keep the muzzle pointed in a safe direction! Never attempt to load or unload any firearm inside a vehicle, building or other confined space (except a properly constructed shooting range). Enclosed areas offer no completely safe direction in which to point the firearm because you don't know what is behind. If an accidental discharge occurs, there is great risk of injury, death, or property damage. Before loading, always clean all, grease and oil from the bore and chamber, and check to be certain that no obstruction is in the barrel. Any foreign matter in the barrel could result in a bulged or burst barrel or other damage to the firearm and could cause serious injury to the shooter or to others. When hunting in the fields or woods constantly monitor where everybody is. Properly position yourselves, don't let other shooters get even a few feet in front of you or behind you.

 **WARNING! BARREL OBSTRUCTION:** 

If there is any reason to suspect that a bullet or projectile is obstructing the barrel, immediately unload the firearm (See Unloading Instructions) and check the chamber and the bore. A bullet may be lodged some distance down the barrel where it can not

easily be seen. Disassemble barrel from action. Check the bore by using a cleaning rod to pass through the barrel. If a blockage is in the bore, **DO NOT ATTEMPT TO SHOOT IT OUT WITH ANOTHER CARTRIDGE, OR BLOW IT OUT WITH A BLANK CARTRIDGE OR A CARTRIDGE FROM WHICH THE BULLET HAS BEEN REMOVED. SUCH TECHNIQUE(S) CAN GENERATE EXCESSIVE PRESSURE, DAMAGE THE FIREARM AND CAUSE SERIOUS PERSONAL INJURY.** If the blockage can be removed with a cleaning rod, clean any unburned powder grains from the bore, chambers & mechanism before resuming shooting. If the blockage can not be dislodged by tapping it with a cleaning rod, take the firearm to a qualified gunsmith.

 **WARNING! POINT IN SAFE DIRECTION, ALWAYS:** 

ALWAYS POINT YOUR FIREARM IN A SAFE DIRECTION AT ALL-TIMES, EVEN WHEN CERTAIN FIREARM IS UNLOADED. THIS PRACTICE WILL SERVE YOU WELL WHEN IN THE EXCITEMENT OF THE HUNT. Think ahead. Example: Don't lean loaded gun against yourself. As you pick up bird, your dog may hit trigger.

 **WARNING! NO SHOOTING FROM BOATS:** 

Do not shoot from a boat. Do not shoot from a canoe, standing or sitting. Because the recoil will make the canoe/boat turn over, dropping you into the water. This may cause drowning or hypothermia, which also may lead to death.

 **WARNING! LIGHTNING STORMS:** 

Do not hunt, shoot, or stand in a lightning storm. Being struck by lightning will cause death or serious injury.

 **FIRING WARNING!** 
**EYE AND EAR
PROTECTION:**

When shooting, full eye and ear protection is mandatory at all times. Shooters and spectators must wear shooting glasses and sound suppressor to prevent eye injury and hearing loss. Vision loss and hearing impairment can occur with only one moment of non-protection.

 **WARNING!** 
**Mechanical
Malfunctions:**

STOP SHOOTING IMMEDIATELY AND UNLOAD YOUR FIREARM if your Firearm develops: a mechanical malfunction; binding or stoppage; spitting powder/gas; cartridge primer is punctured; a cartridge case is bulged or ruptured; or the sound on firing does not sound quite right. **Do NOT** try one more shot but unload your firearm and take it and the ammunition to a qualified gunsmith or send it back to Guns INC. for examination. Do not assume that the firearm is empty merely because you checked the chamber. You must also check the bore for any fired shot or wad jammed inside the barrel.

Check for any kind of obstruction, including mouse nests, dead mouse, or spider webs, ice, snow, or mud.

 **WARNING!** 
**Hang Fire / Possible
Delayed Discharge:**

IF GUN FAILS TO FIRE, AS ALWAYS WATCH WHERE YOUR MUZZEL IS POINTING, WAIT FOR POSSIBLE DELAYED DISCHARGE FOR 5 MINUTES. SOMETIMES SLOW PRIMER IGNITION WILL CAUSE A "HANGFIRE" AND THE CARTIDGE WILL GO OFF AFTER A SHORT PAUSE. IF IT STILL FAILS TO FIRE, AGAIN, KEEP MUZZEL POINTED IN SAFE DIRECTION AT ALL TIMES, AVOID EXPOSURE TO THE BREECH. KEEP YOUR FACE AWAY FROM THE BREECH, THEN CAREFULLY OPEN ACTION, UNLOAD CARTRIDGE IN THOUGHTFUL SAFE WAY. DISPOSE OF CARTIRIDGE IN THOUGHFUL SAFE WAY.

LEGAL NOTICE

PISTOLS ARE CLASSIFIED AS FIREARMS OR DANGEROUS WEAPONS, and are sold by GUNS INC. / R.OX. NJ with the specific understanding that we are not responsible in any manner what -so-ever for their safe handling or resale under local laws and regulations. GUNS INC. / R.OX. NJ shall not be responsible in any manner whatsoever for the malfunctioning of the firearm, for physical injury or death, or for property damage resulting in whole or in part from (1) intentional or negligent discharge, (2) improper or careless handling, (3) unauthorized modifications and/or alteration to the internal/safety mechanisms, barrel, or other parts, (4) defective, improper, high pressure, hand-loaded, reloaded ammunition, non standard, damaged, or old ammunition, (5) abuse of firearm or lack of proper maintenance, corrosion, or lack of inspection by competent qualified gunsmith (6) neglect, or (7) other influences beyond our direct and immediate control. This limitation applies regardless of

whether liability is asserted on the basis of contract, negligence or strict liability (including any failure to warn). Under no circumstances shall I importer R.OX. NJ be liable for incidental or consequential damages, such as loss of use of property, commercial loss and loss of earnings or profits.

