

M107A1

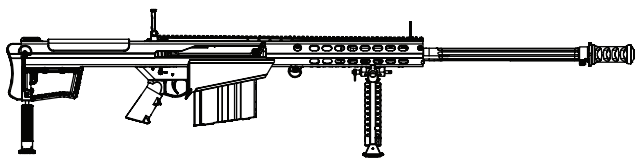

M107A1
OPERATOR'S MANUAL



TABLE OF CONTENTS

- 2 MANUFACTURER'S DISCLAIMER**
- 2 USE OF THIS MANUAL**
- 3 SAFETY GUIDELINES**
- 5 WARRANTY AND SERVICE**
- 6 DESCRIPTION OF THE FIREARM**
- 7 BREAK-IN PROCEDURE**
- 7 SPECIFICATIONS**
- 8 MAJOR COMPONENTS**
- 8 SAFETY MECHANISM**
- 9 BIPOD OPERATION**
- 9 SIGHTS**
- 11 ASSEMBLY OF MAJOR COMPONENTS**
- 15 LOADING AND FIRING**
- 18 UNLOADING AND CLEARING RIFLE**
- 19 UNLOADING THE MAGAZINE**
- 20 REMOVING THE MAINSPRING AND BUFFER**
- 21 INSTALLING THE MAINSPRING AND BUFFER**
- 23 CLEANING AND LUBRICATION**
- 24 GENERAL MAINTENANCE**
- 25 INSPECTION OF MAJOR COMPONENTS**
- 29 TROUBLESHOOTING**
- 32 EXPLODED VIEW AND PARTS LIST**

B MANUFACTURER'S DISCLAIMER

BFMI will not be responsible for injury, death, or damage to property resulting from either intentional or accidental discharge of this firearm or from its function when used for purposes or subjected to treatment for which it was not designed. BFMI will not honor claims involving this firearm which result from careless or improper handling, unauthorized adjustment or parts replacement, corrosion, neglect, the use of the wrong caliber ammunition, or the use of other than commercially manufactured ammunition in good condition, or any combination thereof.

USE OF THIS MANUAL

Read this manual before you use or manipulate your Barrett product. It is important that you understand the principles of safe firearm handling in general and the features of this product. This manual is not a substitute for training from a qualified instructor. Important safety topics are discussed in this chapter and throughout this manual. This manual should remain with the product and it should be transferred with the product to subsequent owners. Additional manuals can be ordered from Barrett Firearms Manufacturing or can be downloaded from the company website, **barrett.net**. Technical specifications are subject to change without notice. Please ensure you have the most updated revision of this manual by checking **barrett.net**. The revision letter can be found on the back of this manual.

SAFETY GUIDELINES



**FAILURE TO FOLLOW SAFETY GUIDELINES
MAY CAUSE INJURY OR DEATH**

AMMUNITION

Do not use hand loaded, re-manufactured, or surplus ammunition. Always use new, clean, dry, properly stored, and correct caliber ammunition from reputable manufacturers.

SAFETY DISTANCE

Bullets fired from this rifle may travel as far as 4 miles. Make certain that you have an adequate backstop.

HEARING PROTECTION

Always wear adequate hearing protection when the rifle is firing; wear both earplugs and shooting muffs together for maximum protection. This includes observers. Observers should always be behind the shooter.

EYE PROTECTION

Appropriate eye protection should be worn when both shooting and maintaining your rifle. It is normal for firing to generate airborne dust and debris. Protect your eyes from solvents and uncaptured parts under spring pressure while performing maintenance on your rifle.

MUZZLE CONTROL

Always keep the muzzle pointed in a safe direction. Never allow your muzzle to point at anything that you do not intend to shoot. Upon firing the muzzle brake releases high-pressure gas from its side ports that can damage objects or cause injuries, keep everything away from the vicinity of the muzzle brake.

ASSUME EVERY FIREARM IS LOADED

Always treat every firearm as if it were loaded. Look and feel for an empty chamber. Do not trust the extractor to provide an empty chamber.

BEWARE OF BARREL OBSTRUCTIONS

Ensure the barrel's bore is free of obstructions before you fire your rifle. Even the smallest obstruction such as a stuck patch or even grease will cause increased pressures that can rupture the barrel.

KEEP YOUR FINGER OFF THE TRIGGER

Keep your finger off the trigger and out of the trigger guard until your sights are aligned on your target and you intend to fire.

KEEP YOUR SAFETY ON

Keep your safety on until your sights are aligned on your target and you intend to fire.

FAILURE TO FIRE

If your rifle fails to fire when you pull the trigger, do not pull the charging handle. Keep the rifle pointed toward a safe area and wait 2 minutes. If a hang-fire (slow ignition) has occurred, the round will probably fire within two minutes. If the round does not fire, remove and inspect the cartridge. If the primer is indented properly, discard it in a safe manner.

MAINTAIN YOUR RIFLE PROPERLY

Performing proper maintenance, as outlined in this manual, insures that your rifle will be safe to shoot and will perform to design specification for many years. Alterations, modifications or adjustments may damage your rifle, make it unsafe to fire, and will void warranty claims.

STORE YOUR RIFLE SAFELY

It is your responsibility to take reasonable precaution to secure your rifle, keep it properly secured and prevent unauthorized use.

ALCOHOL, MEDICATIONS AND DRUGS

Do not handle or operate your rifle under the influence of alcohol, medication, or drugs.

WARRANTY AND SERVICE

For one year from date of purchase, Barrett Firearms Manufacturing Inc. (BFMI), warrants to the original owner, that this product was manufactured free of defects in materials and workmanship. BFMI will correct any defect covered under the warranty by repair or replacement with the same or comparable model. BFMI will not be responsible for injury, death, or damage to property resulting from either intentional or accidental discharge of this firearm or from its function when used for purposes or subjected to treatment for which it was not designed. BFMI will not honor claims involving this product which result from careless or improper handling, unauthorized adjustment or parts replacement, corrosion, neglect, the use of the wrong caliber ammunition, or the use of other than commercially manufactured ammunition in good condition, or any combination thereof. Please visit **barrett.net** for any additional information.

If you need factory service, whether covered under warranty or not, please contact BFMI for instructions on how to have your rifle repaired.

**Barrett Firearms Manufacturing Inc.
P.O. Box 1077
Murfreesboro, TN 37133-1077
615-896-2938**

DESCRIPTION OF THE FIREARM

The M107A1 is a semi-automatic, recoil operated rifle chambered in .50 BMG (**FIGURE 1**). The rifle is fed from a 10 round detachable magazine. With its low felt recoil and self-loading action, the M107A1 offers rapid, accurate fire power. The muzzle brake, dual barrel springs and long mainspring design make the rifle comfortable to shoot.

The M107A1 has been upgraded with cutting-edge materials and technology to further increase performance. An upgraded bolt, bolt carrier, and hydraulic buffer allow the rifle to operate more reliably while suppressed or in extreme conditions. Other upgrades, such as the barrel extension, rear hand grip and ejector improve the operation, durability and overall function of the rifle system.

The rifle is shipped from the factory in 2 pieces: the upper receiver complete and lower receiver complete. It is recommended to always store and transport the M107A1 in the provided airtight, watertight carrying case.

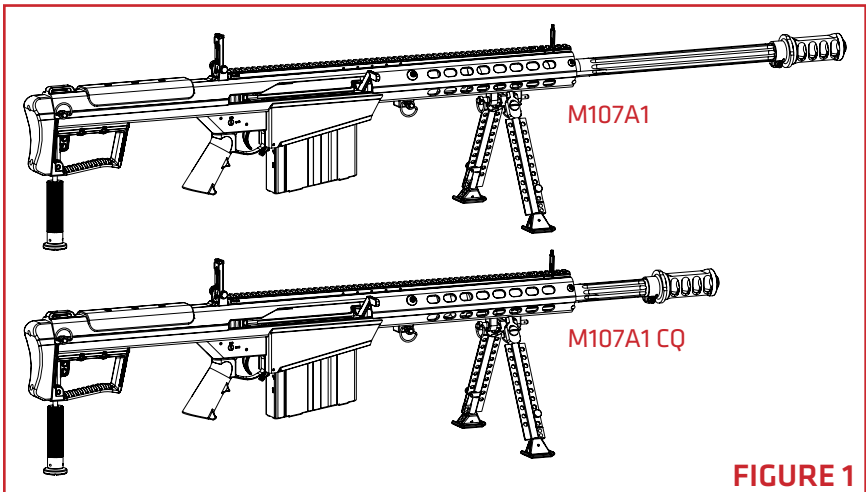

FIGURE 1

BREAK-IN PROCEDURE

Barrett does not offer a specific procedure for barrel break-in other than checking for obstructions and using your new rifle.

Experience has shown that the bore becomes less prone to fouling over time and that accuracy may improve with use. Ensure that the rifle is adequately lubricated and follow the loading/unloading and safety procedures when operating your rifle.

SPECIFICATIONS

MODEL	M107A1	M107A1 CQ
Caliber	.50 BMG (12.7 x 99 mm)	.50 BMG (12.7 x 99 mm)
Operation	Semi-Automatic	Semi-Automatic
Weight	27.55 lbs (12.5 kg)	26.26 lbs (11.91 kg)
Overall Length (Assembled)	56.8" (1442.8 mm)	48.4" (1229.4 mm)
Length (Takedown Mode)	37.75" (958.9 mm) Lower 41.38" (1050.9 mm) Upper	37.75" (958.9 mm) Lower 41.38" (1050.9 mm) Upper
Barrel Length	29" (736.6 mm)	20.6" (523.2 mm)
Barrel Twist	1:15	1:15
Magazine Capacity	10 rounds	10 rounds
Stock	Integral with lower receiver - steel	Integral with lower receiver - steel
Safety	Manual thumb-lever	Manual thumb-lever
Sights	Fixed front, Adjustable rear sights	Fixed front, Adjustable rear sights
Muzzle Velocity (Standard 660 grains (42.8 g) Projectile)	2750 f/s (853 m/s)	2500 f/s (762 m/s)

MAJOR COMPONENTS - FIGURE 2

1. Upper receiver
2. Bolt carrier group
3. Lower receiver
4. Magazine

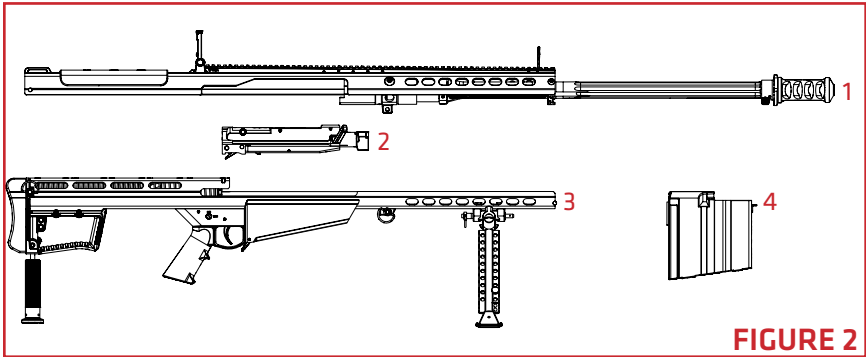

FIGURE 2

SAFETY MECHANISM

The safety mechanism is located above the grip on the left side of the lower receiver. To place the rifle in the safe mode, push the safety lever selector to the “Safe” position. To place it in the fire mode, push the safety lever to the “Fire” position. (FIGURE 3)

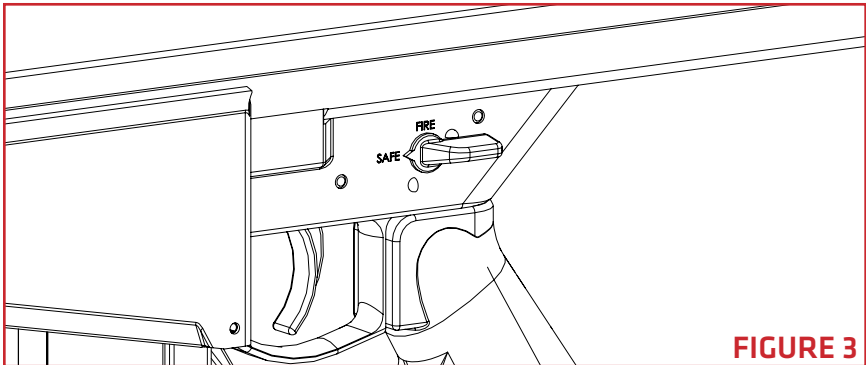

FIGURE 3

BIPOD OPERATION

The bipod assembly is used to fire from the prone position and assist in operator manipulation of the firearm.

To reposition the bipod legs, pull each bipod leg away from the yoke (**FIGURE 4-A**) and rotate to the desired position (**FIGURE 4-B**). The bipod leg will lock into place (forward, rearward, and 90 degrees from the receiver). The bipod legs of the M107A1 extend to increase height.

Pulling on the feet of the bipod causes the legs to extend. To retract a leg, depress the plunger located on the bipod leg and push on the foot (**FIGURE 4**).

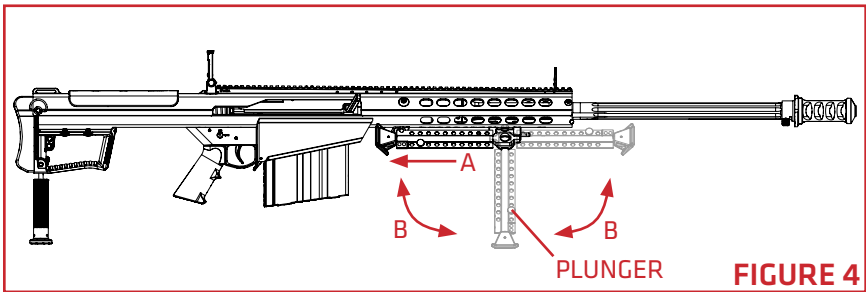

SIGHTS

This section provides information on how to make sight corrections to zero the M107A1 iron sights and make elevation/windage adjustments. Only the rear sight is adjustable for elevation and windage (**FIGURE 5**).

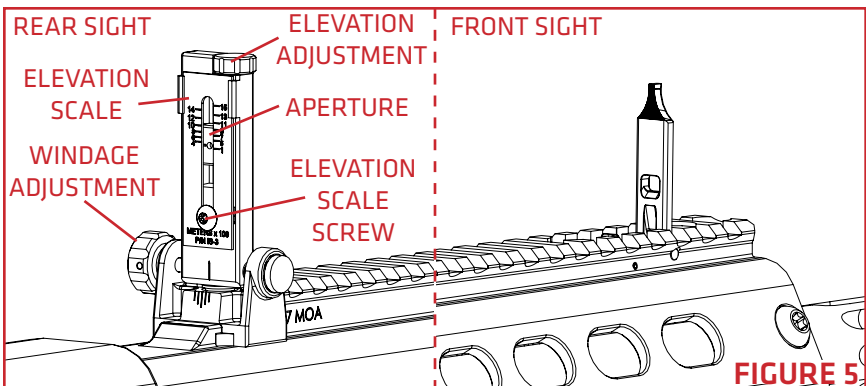

ZEROING PROCEDURE

Using a bore collimator or laser bore sight, project to a 100 meter distance. Rotate the elevation adjustment knob on the rear sight to vertically adjust the aperture to be aligned with the collimator/laser. Loosen the elevation scale screw (**FIGURE 5**) and adjust the scale to align the 100 meter mark with the aperture. Tighten the elevation scale screw then fire a test group to confirm zero. If needed, make small additional adjustments to the elevation knob until zeroed at 100 meters.

WARNING

ENSURE COLLIMATOR OR LASER BORE SIGHT IS REMOVED BEFORE FIRING RIFLE.

ELEVATION/WINDAGE CORRECTION

With the M107A1 iron sights zeroed, the rear sight can be used for quick elevation and windage adjustments. Elevation adjustments are performed made by rotating the elevation screw on the top of the rear sight body. Windage adjustments are performed by rotating the windage knob on the left side of the rear sight (**FIGURE 5**). When rotating the adjustment knobs clicks can be heard and felt. The table displays the POI shift at specific distances for each windage adjustment click.

ONE CLICK MOVES POINT OF IMPACT LEFT OR RIGHT

Range	Centimeters	Inches
100 meters	1.47	0.58
200 meters	2.97	1.17
300 meters	4.44	1.75
400 meters	5.92	2.33
500 meters	7.39	2.91
600 meters	8.89	3.5
700 meters	10.36	4.08
800 meters	11.84	4.66
900 meters	13.31	5.24
1000 meters	14.8	5.83

ASSEMBLY OF MAJOR COMPONENTS

1. Extend the bipod legs on the lower receiver by pulling the legs down (1) to the front, where they will lock into place. Place the lower receiver on a level surface.

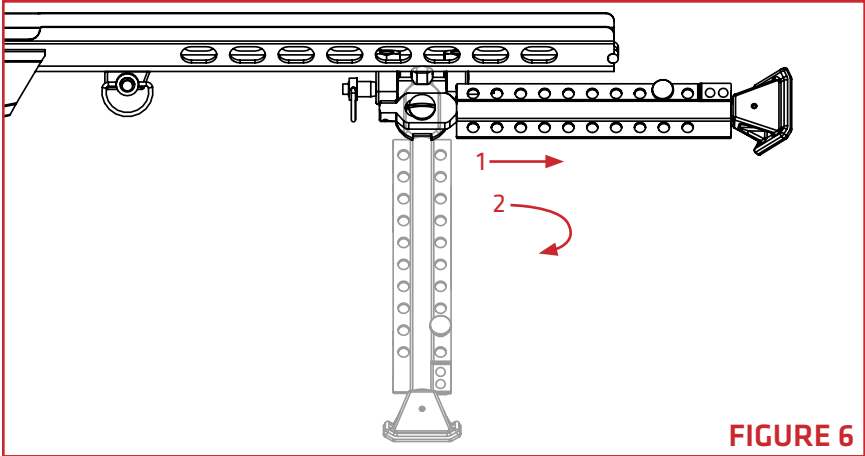

FIGURE 6

2. The bolt carrier group is held in place under tension in the lower receiver by the midlock pin, which extends through a vent hole in the lower receiver and into the bolt carrier (FIGURE 7). (Both the midlock pin and the rear lock pin, located in a retaining hole in the end of the lower receiver, have finger rings to aid in removal.)

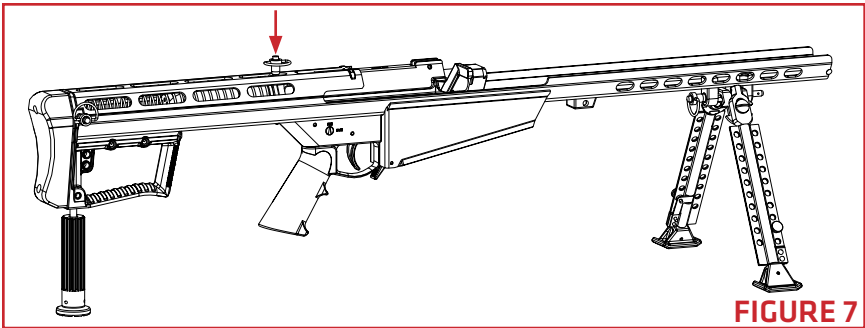
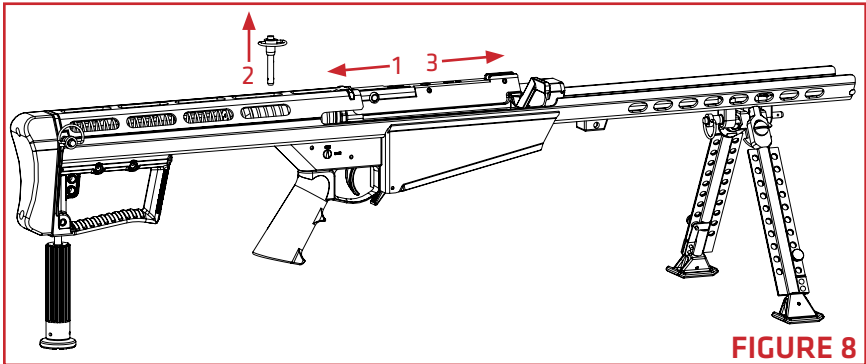
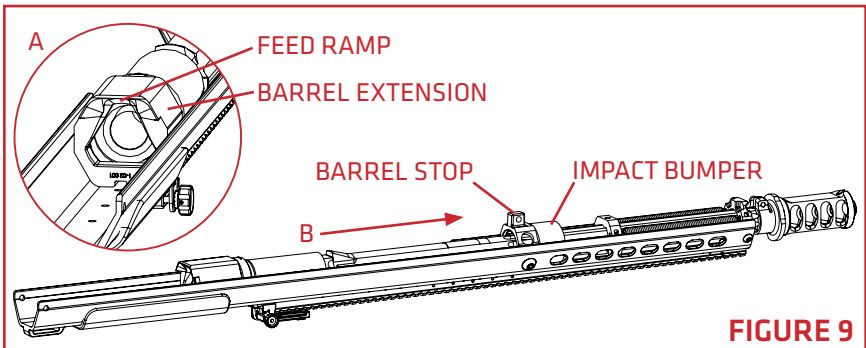

FIGURE 7

3. Standing above and to the rear of the lower receiver, grasp the charging handle with the right hand, and carefully pull back (1), against tension, while withdrawing the midlock pin from its retaining hole (2). The button on the midlock pin must be pressed for it to be removed. Allow the bolt carrier to come forward SLOWLY until there is no more spring tension and it rests in the lower receiver (3) (**FIGURE 8**).

**FIGURE 8**

4. Carefully pick up the upper receiver. The barrel will be nested inside for compact storage. Ensure the barrel is rotated so that the barrel extension and feed-ramp is correctly aligned (**FIGURE 9-A**). Slide the barrel forward until it is fully seated against the barrel stop (**FIGURE 9-B**). Slide the impact bumper into position on the large diameter of the barrel and against the barrel stop.

**FIGURE 9**

⚠ WARNING

THE TENSION ON THE BARREL SPRINGS IS APPROXIMATELY 70 lbs (32 kg). SERIOUS INJURY COULD RESULT IF SPRINGS ARE SUDDENLY RELEASED

- The barrel springs at the front of the upper receiver are held in by the barrel key and the front barrel bushing. The rear lock pin can be locked into the barrel key to help provide additional leverage and create a handhold. While maintaining the downward tilt of the upper receiver (to keep the barrel in place), firmly grasp the rear lock pin locked into the barrel key—not the springs—and pull it into place on the forward slot of the barrel (**FIGURE 10**). Work the barrel key until it is firmly seated in the barrel slot. Remove the rear lock pin from the barrel key. The upper receiver is now fully assembled.

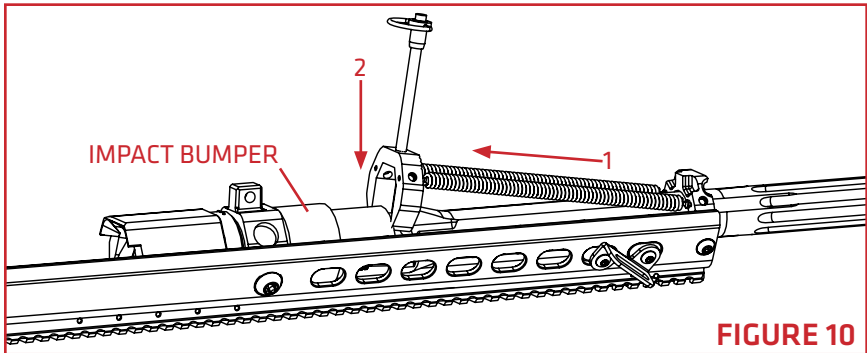
**FIGURE 10**

- Rotate the upper receiver top rail to the 12 o'clock position then place the upper receiver over the lower receiver.
- Engage the notch in the front barrel bushing of the upper receiver with the front hinge pin of the lower receiver. To help couple the notch in the front barrel bushing and the front hinge pin of the lower receiver, tilt the upper receiver upwards to a 45-degree angle (**FIGURE 11**).

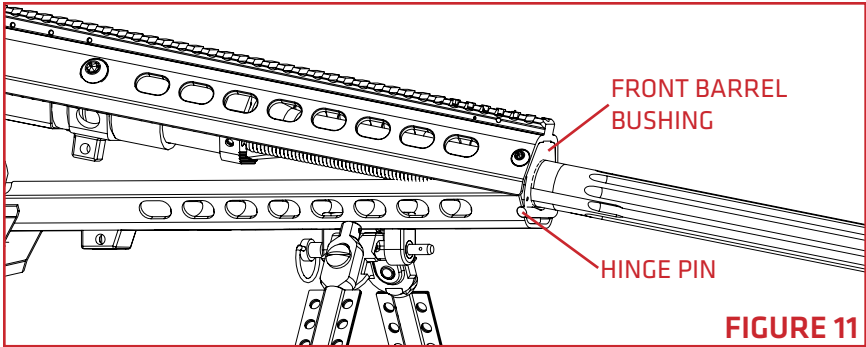

8. While positioned directly behind the rifle, grasp the charging handle and pull rearward against mainspring tension so the bolt will clear the barrel extension when the upper receiver is lowered (**FIGURE 12**).

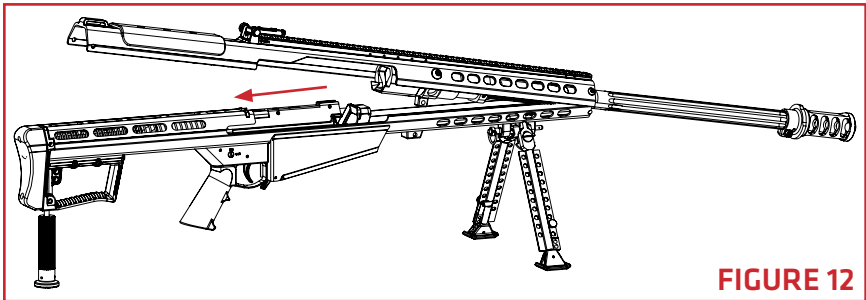

9. Close the upper receiver onto the lower receiver. With the bolt retracted, the upper receiver should fit into the lower receiver easily without being forced. If the upper does not fit on the lower, check front barrel bushing/hinge pin alignment. Release the charging handle SLOWLY until the bolt is fully closed (**FIGURE 13**).

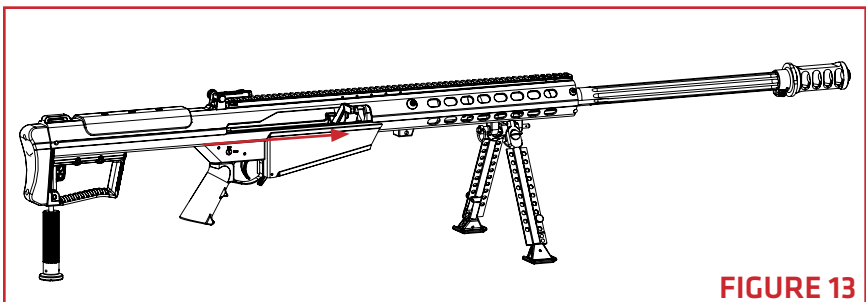

- Place the midlock pin (shorter pin) through the midlock hole in front of the magazine well on bottom of the rifle until it is fully seated, locking the upper and lower receivers together. Insert the rear lock pin through the rear lock hole of the upper receiver to complete the mating of the receivers (**FIGURE 14**). (Both the midlock pin and the rear lock pin, have a detent button that will need to be depressed and finger rings to aid in removal and installation.)

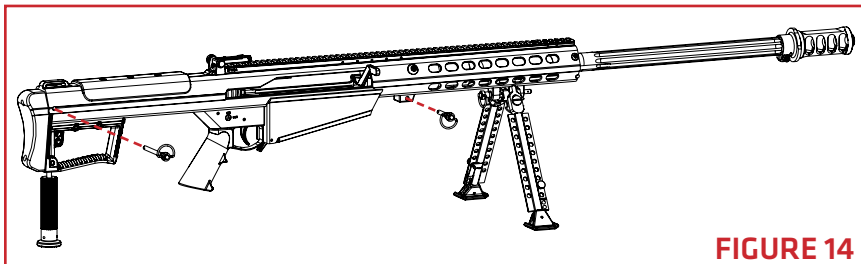
**FIGURE 14****⚠ WARNING**

THE RIFLE MUST NOT BE FIRED WITHOUT BOTH THE MIDLOCK AND REAR LOCK PINS FIRMLY IN PLACE. SERIOUS INJURY OR DEATH COULD RESULT.

LOADING AND FIRING

- Using appropriate ammunition, load the magazine in the normal manner (**FIGURE 15**). Ensure that cartridges are pushed all the way to the rear of the magazine. Load no more than 10 rounds.

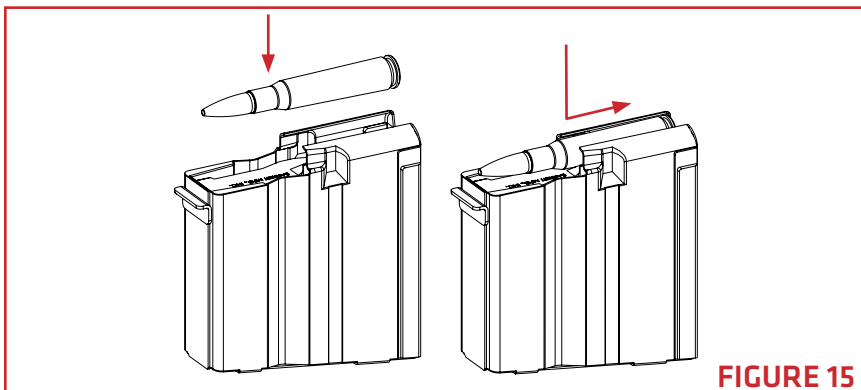
**FIGURE 15**

2. Ensure the safety lever is pointed towards SAFE (**FIGURE 16**).

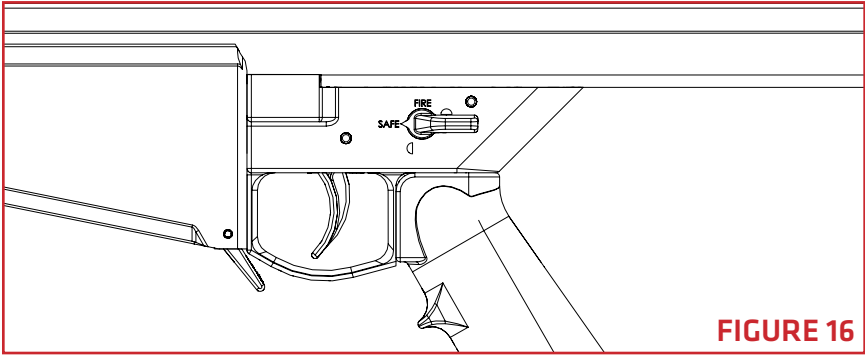
**FIGURE 16**

3. Insert the magazine into the magazine well in the lower receiver, with magazine tilted at approximately a 45° angle (bullet tips upward). Insert the front of the magazine hook to its hinge, located in the front of the magazine well (1). Swing the rear of the magazine up until it locks into place by means of the magazine catch (2) (**FIGURE 17**). It should lock in with an audible click. Tug down on the magazine to ensure it is properly seated.

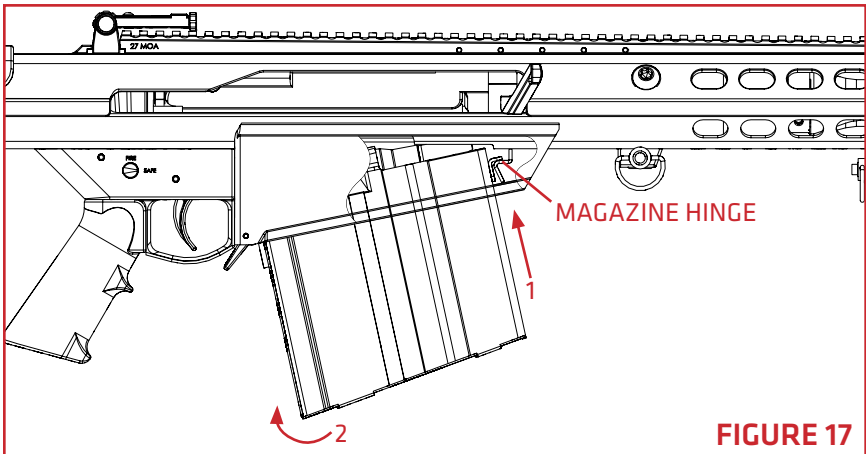
**FIGURE 17**

4. With the safety in the safe position (safety lever horizontal) and the muzzle pointed in safe direction pull the charging handle to the rear until it stops, then release it (do not keep your hand on the charging handle). The rifle then loads and locks under its own spring power for all subsequent rounds.

⚠ WARNING

DO NOT ATTEMPT TO FORCE A CARTRIDGE INTO THE CHAMBER BY FORCING THE BOLT CLOSED. IF THE BOLT DOES NOT CLOSE EASILY, REMOVE THE CARTRIDGE AND EXAMINE IT FOR DAMAGE OR DEFECTS. CHECK THE CHAMBER FOR OBSTRUCTIONS.

⚠ WARNING

DOUBLE HEARING PROTECTION SHOULD BE WORN WHEN FIRING SINCE HARMFUL LEVELS OF NOISE ARE GENERATED.

⚠ WARNING

THE SHOOTER MUST BE POSITIONED DIRECTLY BEHIND THE RIFLE WITH THE RECOIL PAD HELD FIRMLY AGAINST THE SHOULDER. FIRING THE RIFLE IN ANY OTHER POSITION COULD RESULT IN INJURY BY CONTACT WITH THE RIFLE OR RIFLE SCOPE.

5. Because the rifle is recoil-operated, the shooter must be positioned squarely behind the rifle, with the recoil pad firmly against the shoulder. Anything less may result in injury, discomfort, or failure of the action to cycle correctly.
6. Rotate the safety to the FIRE position (**FIGURE 18**).

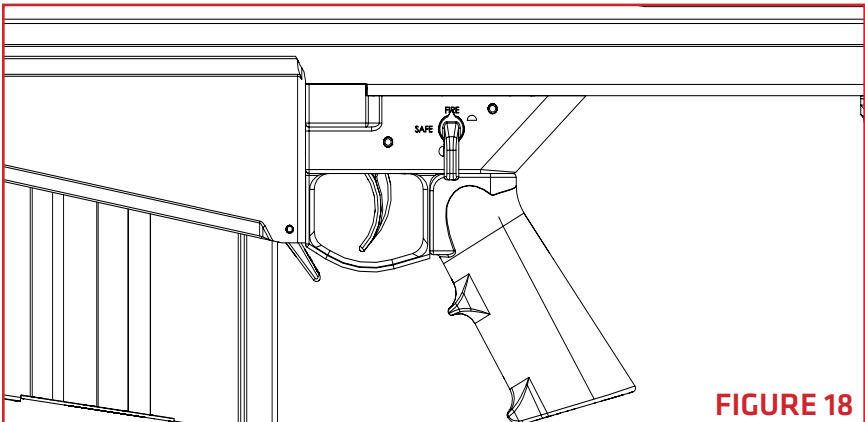
**FIGURE 18**

- The rifle may now be fired. The rifle will fire one round for each pull of the trigger, until the magazine and chamber are empty.

⚠ WARNING

THE BOLT DOES NOT AUTOMATICALLY REMAIN TO THE REAR WHEN THE RIFLE OR MAGAZINE IS EMPTY. ALWAYS PULL THE CHARGING HANDLE TO THE REAR TO INSPECT CHAMBER FOR AMMUNITION.

- After the magazine is emptied, or you are done firing, place the safety lever in the safe position with the muzzle pointed in a safe direction and remove magazine. Clear the firearm by pulling the charging handle to the rear several times; visually and physically check the chamber for ammunition.

UNLOADING AND CLEARING RIFLE

- Place the safety lever in the “SAFE” position.
- Press the magazine catch forward, towards the magazine and remove the magazine (**FIGURE 19**).

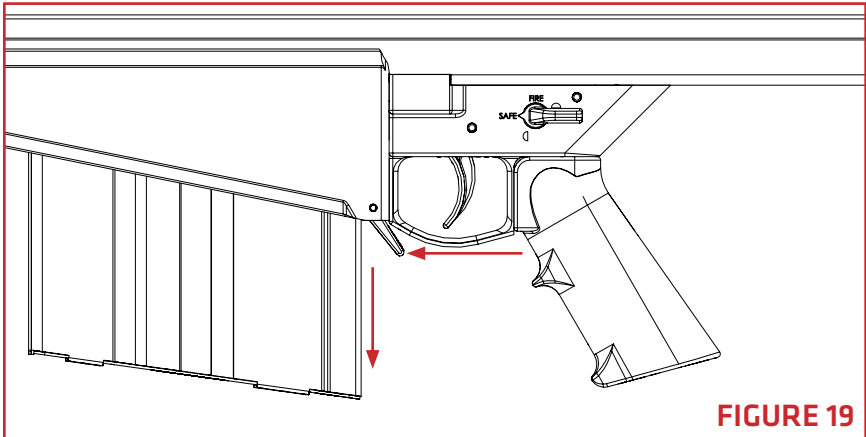

3. Pull the charging handle to the rear, and visually and physically check the chamber for ammunition (**FIGURE 20**). Insert a chamber flag into the ejection port to indicate the rifle is clear.

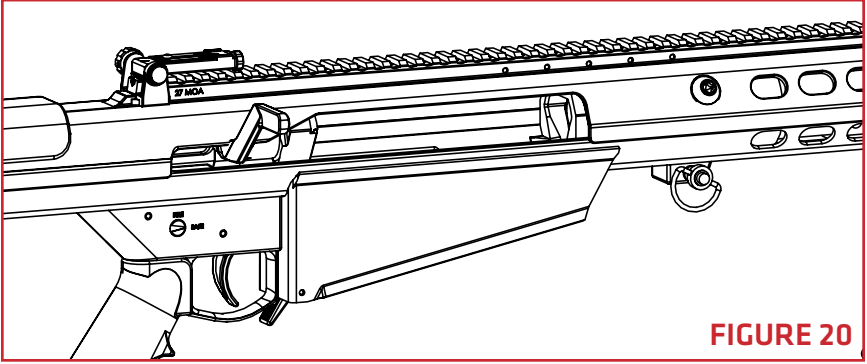
**FIGURE 20**

⚠ WARNING

RECENTLY FIRED BRASS MAY BE VERY HOT

UNLOADING THE MAGAZINE - FIGURE 21

1. Hold the magazine in either the right or left hand, cartridges facing away from you.
2. Using the thumb of the other hand, push the cartridges forward and out one after another, until all are ejected.

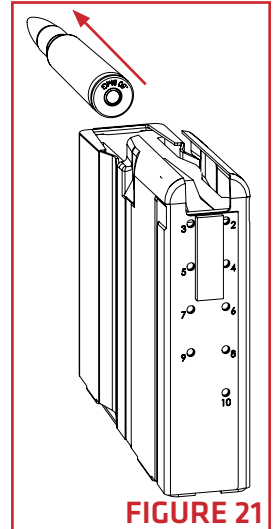
**FIGURE 21**

REMOVING THE MAINSPRING AND BUFFER

1. Remove hydraulic buffer to expose buffer sleeve (**FIGURE 22**).

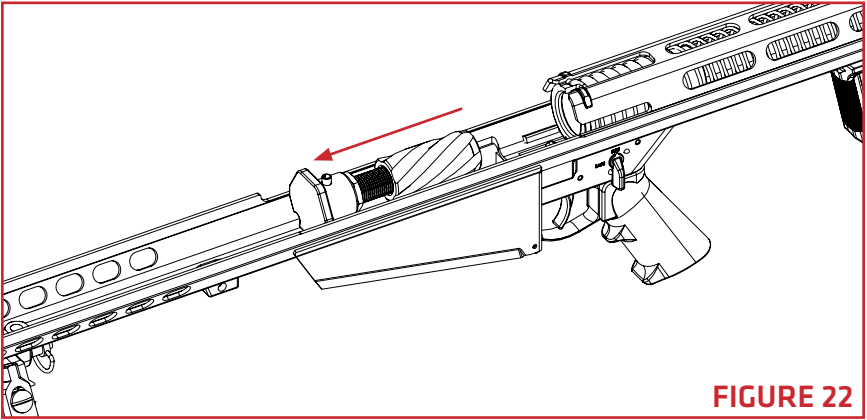

FIGURE 22

2. While maintaining constant control and pressure, rotate the buffer and spring to align the buffer notch with buffer stop on lower receiver (**FIGURE 23**).

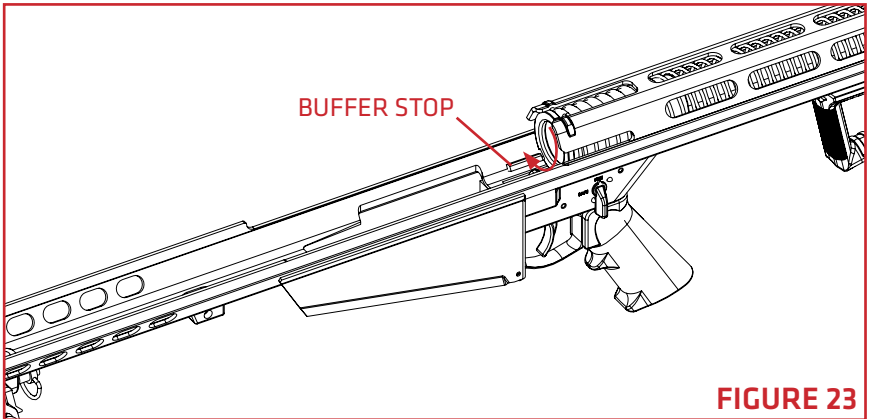

FIGURE 23

3. Allow buffer sleeve and mainspring to fully extend then remove (**FIGURE 24**).

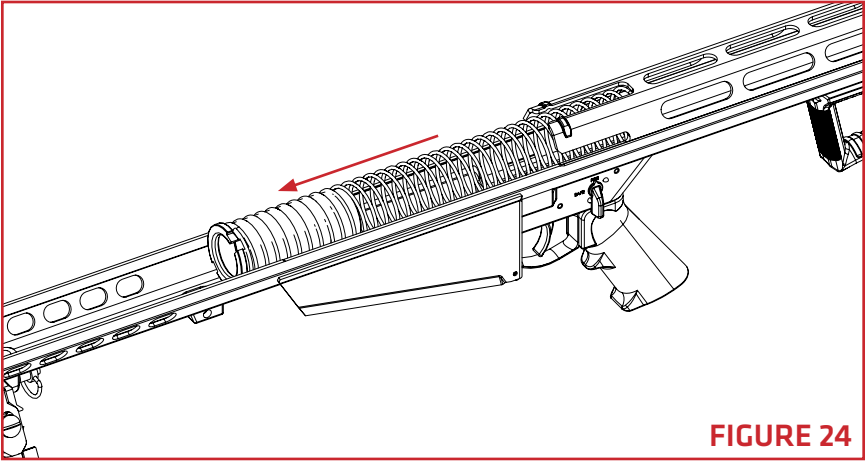

FIGURE 24

INSTALLING THE MAINSPRING AND BUFFER

1. Place buffer sleeve and mainspring into the lower receiver and align the buffer sleeve notch with the welded buffer stop of the lower receiver. (FIGURE 25).

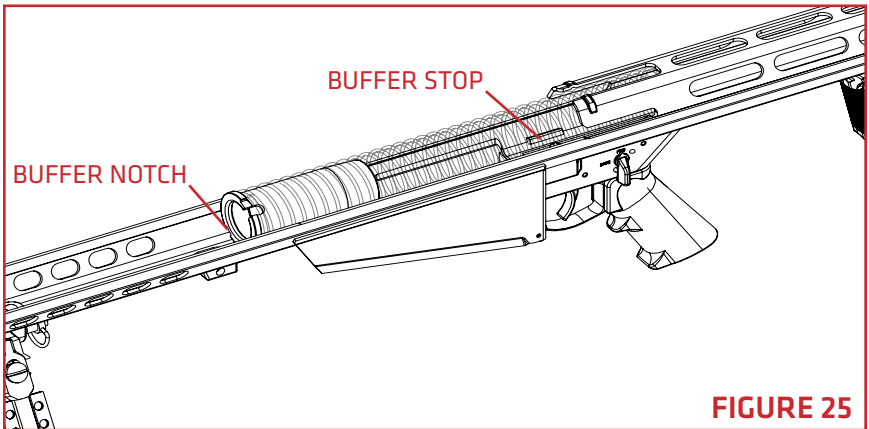

FIGURE 25

2. Push the buffer sleeve and mainspring into the lower receiver in one continuous, fluid motion. Once pushed past the buffer stop, rotate the buffer sleeve to align the notches vertically with the larger notch on top (FIGURE 26).

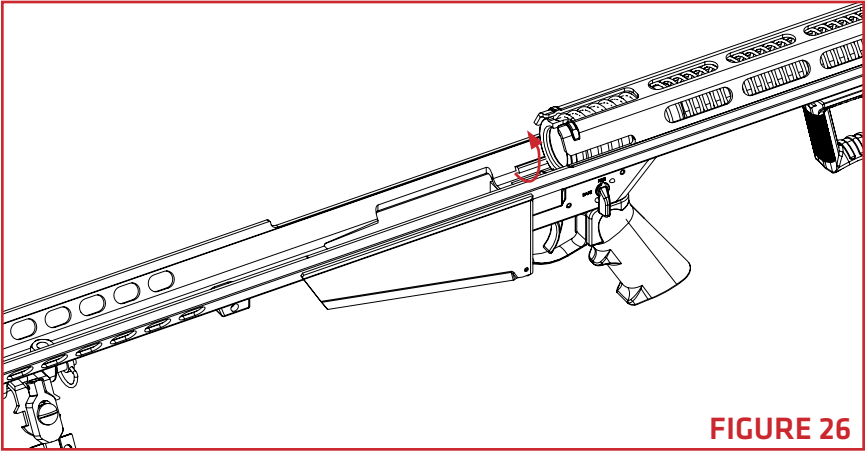

FIGURE 26

3. Insert the hydraulic buffer and ensure the index pin on the buffer nests inside the grooves in the buffer sleeve (**FIGURE 27**).

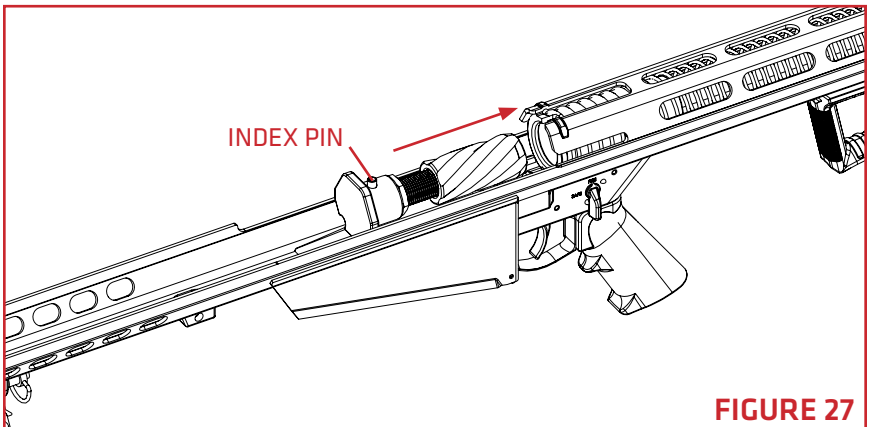

FIGURE 27

⚠ WARNING

**UNLOAD AND CLEAR THE RIFLE BEFORE DISASSEMBLY.
ENSURE NO LIVE AMMUNITION IS PRESENT DURING
DISASSEMBLY OR ASSEMBLY.**

⚠ CAUTION

**DO NOT INSERT CLEANING RODS THROUGH THE MUZZLE.
THE BARREL CROWN COULD BE DAMAGED WHICH WOULD
SEVERELY DEGRADE THE ACCURACY OF THE RIFLE.**

CLEANING AND LUBRICATION

1. The rifle should be cleaned and lubricated after each shooting session.
2. Apply cleaning solvent to a chamber brush and clean the chamber. Barrett Heavy Bore Cleaner is recommended.
3. Apply cleaning solvent to a bore brush and clean the bore. Barrett Heavy Bore Cleaner is recommended.
4. Clean the muzzle brake with a stiff plastic brush and bore solvent. It is best to clean the muzzle brake at the same time the barrel is being cleaned as the bore solvent will help loosen the carbon build-up on its interior walls.
5. Clean the bolt face with bore solvent. Use a stiff plastic brush to remove carbon from both the extractor and the ejector. Depress the ejector and extractor by hand to test for smooth function.
6. Use dry patches as necessary to remove cleaner from the bore and chamber.
7. Clean the remainder of the rifle with cotton-tipped swabs, general-purpose brushes and rags. Make sure all metal surfaces are coated with preservative oil.

⚠ WARNING

TO PROTECT THE RIFLE FROM CORROSION, THE RIFLE AND THE INTERIOR OF THE CARRYING CASE SHOULD BE MOISTURE FREE BEFORE THE RIFLE IS PLACED IN THE CARRYING CASE FOR STORAGE.

GENERAL MAINTENANCE

1. Ensure that all bearing surfaces and exposed parts, particularly those listed below, are clean and properly lubricated:
 - Barrel
 - Bolt and bolt carrier
 - Mainspring housing
 - Trigger assembly
 - Transfer bar assembly
 - Lower receiver

2. Inspect all parts for looseness and tighten or replace, as necessary.
 - Inspect all parts (especially along welds) for cracks or damage and replace, if necessary.
 - Each time the rifle is assembled for firing ensure that the barrel, chamber, and locking lugs of the bolt are free of excess oil. When possible, an operational check using ten dummy rounds should be performed. Insert the dummy rounds into a magazine and load the magazine into the rifle. Manually operate the bolt carrier to the rear and forward, making sure the cartridges feed, extract, and eject properly. If the rifle is not functioning correctly, refer to the Troubleshooting section.
 - Refer to the **TROUBLESHOOTING** section for Malfunction and Immediate Action Troubleshooting.

3. The magazine, chamber/bore, and firing pin channel should be free of cleaner, oil, grease, or other lubrication prior to use

INSPECTION OF MAJOR COMPONENTS - FIGURE 28

The rifle's major groups are packaged as shown below:

1. Upper Receiver
2. Bolt Carrier Group
3. Lower Receiver
4. Magazine

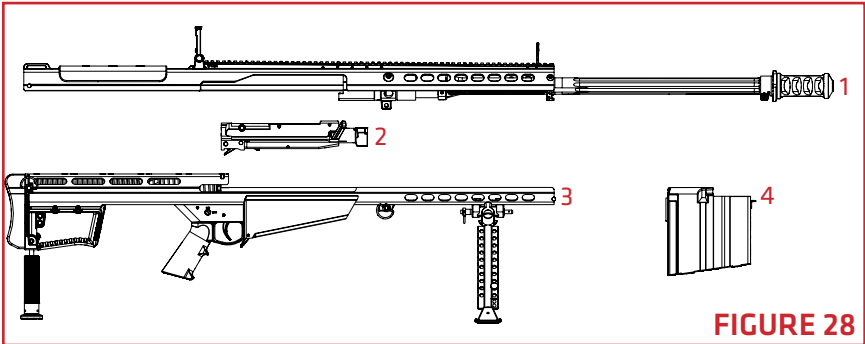

FIGURE 28

Ensure all components are present and inspect for damage. Detailed inspection should be conducted as follows:

⚠ WARNING

UNLOAD AND CLEAR THE RIFLE BEFORE INSPECTION. ENSURE NO LIVE AMMUNITION IS PRESENT DURING THE INSPECTION AND TROUBLESHOOTING PROCESS.

INSPECTION: THE UPPER RECEIVER - FIGURE 29

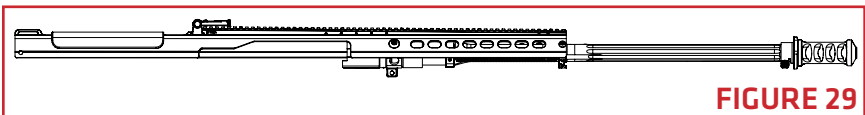
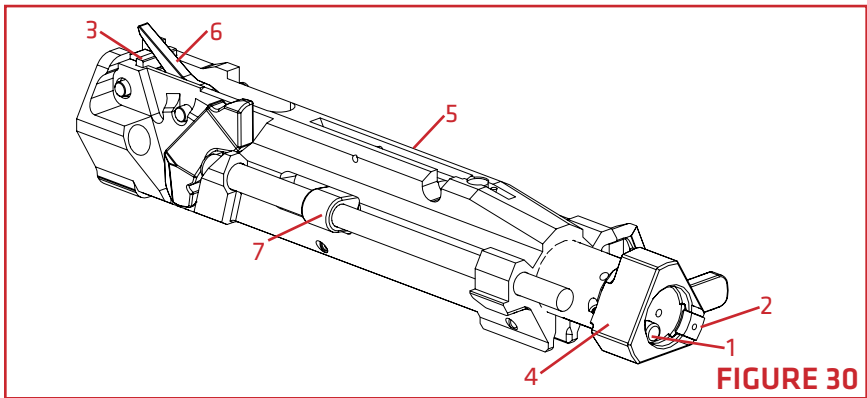

FIGURE 29

1. The barrel springs must not be overstretched, and each coil should be tight, with no spaces between coils when the barrel key is not engaged into the barrel.
2. The battery and impact bumpers should be in good condition (not frayed, cracked, or twisted).
3. The muzzle brake should be tight and fully screwed on.

4. The upper receiver should not be cracked, bent, or burred.
5. Check the front hinge pin slot in the front of the upper receiver to ensure that it is not deformed in any way.
6. The barrel should be clean and free of obstruction and oil.
7. All scope mountings should be tight, in good condition, and free of oil (iron sights, front and rear, may be lightly oiled at pivot points to prevent corrosion).

INSPECTION: THE BOLT CARRIER GROUP - FIGURE 30



1. Ejector (1) and extractor (2) must be checked to ensure they are under spring tension, and neither chipped nor worn and does not stick in one position.
2. De-cock the firing mechanism by using the rear lock pin to depress the sear (**FIGURE 31**). Avoid the cocking lever to reduce chance of being pinched during de-cocking. Manually work the bolt (4) in and out, feeling for any roughness, which may indicate wear, corrosion, or dirt/grit in the bolt carrier(5).

⚠ WARNING

USE REAR LOCK PIN TO DE-COCK THE FIRING MECHANISM. AVOID THE COCKING LEVER TO REDUCE CHANCE OF BEING PINCHED.

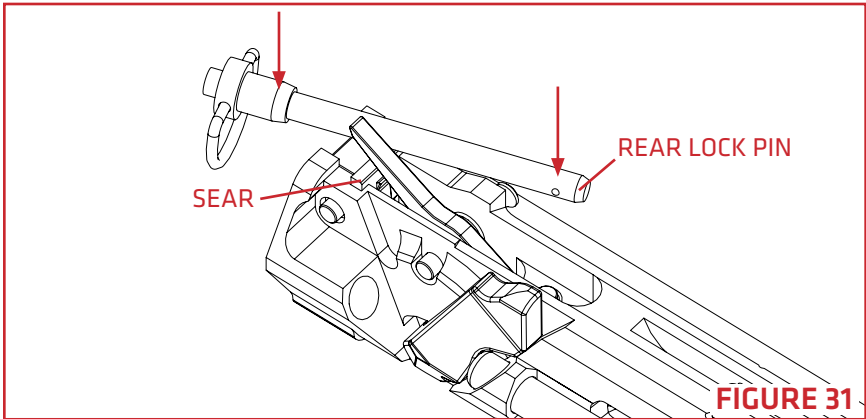

3. Push the bolt into the carrier and inspect for firing-pin protrusion. Check firing-pin hole (on bolt face) to ensure it is not eroded or elongated. Bolt face should not be pitted.
4. Swing the cocking lever (6) forward. The sear (3) should capture the firing-pin extension before the cocking lever is fully depressed.
5. Manual Bolt Extender (7) slot should be free and clear of debris.

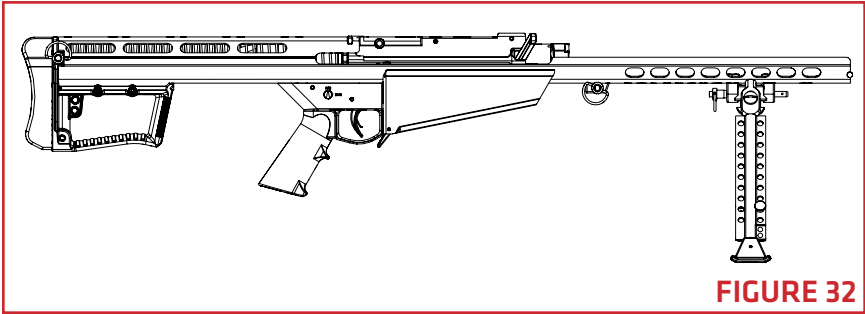
INSPECTION: THE LOWER RECEIVER - FIGURE 32**FIGURE 32**

1. With bolt carrier in place, pull it rearward and check to see that the mainspring moves freely (full travel) and is not deformed.
2. Hold bolt carrier back and down approximately $\frac{1}{4}$ inch (6 mm) under mainspring housing (sheet metal closure). With the thumb safety on fire, pull the trigger. Firing mechanism should function (a slight rise in bolt carrier is normal). If the housing is bent, the bolt carrier will rise excessively as the trigger is pulled, preventing proper functioning.
3. Lower receiver should not be cracked, bent, or burred.
4. Check the hinge pin at the front of the lower receiver to ensure that it is not cracked, bent, or deformed in any way.
5. Check bipod assembly for function and the mounting hardware is tight.

TROUBLESHOOTING

MALFUNCTION	CAUSE	CORRECTIVE ACTION
FAILURE TO FEED	Sluggish action	Clean and lubricate or if cold check for over lubrication
	Check Magazine: a. Proper Installation b. Dirt/Debris c. Damage	a. Reinstall magazine into the receiver b. Clean magazine c. Replace magazine
	Rifle short cycles	Hold rifle more firmly in the shoulder
	Bolt carrier assembly binds	Please contact Tech Support
	Weak/broken mainspring	Replace mainspring
FAILURE TO CHAMBER	Check cartridge for damage	Remove damaged round
	Check for dirty chamber	Clear and clean chamber
	Check for faulty mainspring	Replace mainspring
	Check for bent receiver	Please contact Tech Support
FAILURE TO COCK	Check bolt carrier for proper assembly, worn or missing parts	Replace worn or damaged parts
		Reassemble correctly

MALFUNCTION	CAUSE	CORRECTIVE ACTION
FAILURE TO LOCK OR UNLOCK	Check for obstruction between firing pin and bolt	Disassemble and clean
	Check for excessive dirt or debris in locking area	Clean chamber and barrel extension
FAILURE TO FIRE	Faulty ammunition	Replace ammunition
	Verify bolt carrier is fully in battery	Manually cycle carrier (do not force closed)
	Check for improper installation of firing pin	Assemble properly
	Check for broken or improper installation of trigger components	Replace or reinstall trigger components
	Check for obstruction of the firing pin or trigger	Remove obstruction or debris
FAILURE TO EXTRACT	Check for broken or missing extractor	Replace extractor
	Ensure extractor is moving freely in slot	Remove, clean and lubricate extractor, plunger and spring
	Check for dirty chamber	Clean chamber

MALFUNCTION	CAUSE	CORRECTIVE ACTION
FAILURE TO EJECT	Check for proper movement of ejector	Remove, clean, lubricate or replace ejector and/or spring as needed
VERY HARD RECOIL	Check for faulty/hot ammunition	Replace or cool ammunition
	Check for damaged or missing mainspring/buffer	Replace/install mainspring or buffer as needed
	Check for loose, missing, damaged/ clogged muzzle brake	Please contact Tech Support

EXPLODED VIEW AND PARTS LIST

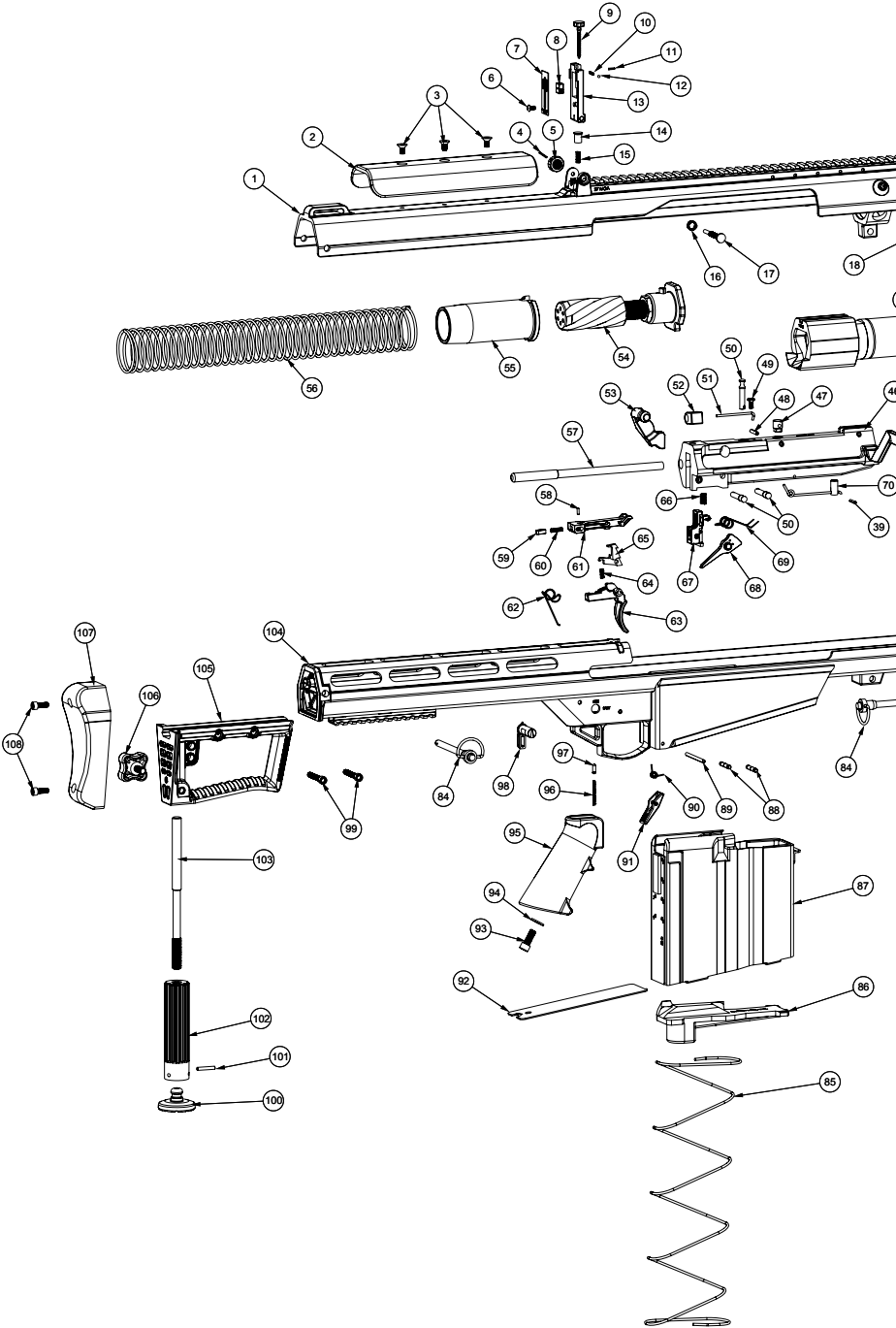

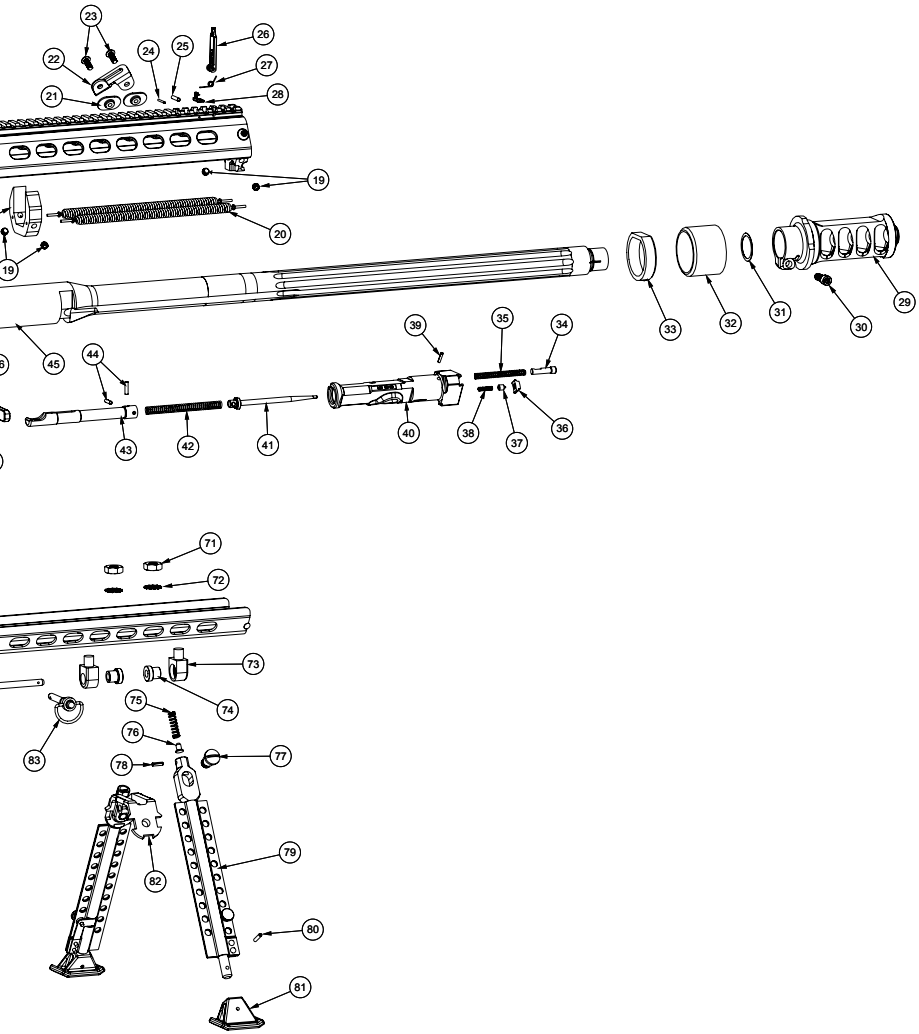

ITEM NO.	DESCRIPTION	QTY.
1	Upper Receiver Complete	1
2	Cheek piece	1
3	Cheek piece Screw	3
4	Windage Knob Pin	1
5	Windage Knob	1
6	Rear Sight Scale Screw	1
7	Rear Sight Scale	1
8	Rear Sight Aperture	1
9	Elevation Screw	1
10	Elevation Screw Spring	1
11	Elevation Screw Pin	1
12	Elevation Screw Ball	1
13	Rear Sight Body	1
14	Rear Sight Base Detent	1
15	Rear Sight Spring	1
16	Windage Screw Spring	1
17	Windage Screw	1
18	Barrel Key	1
19	Barrel Spring Screw	4
20	Barrel Spring	2
21	Center Nut Plate	2
22	Front Sling Loop	1
23	10-32 x.50 BHCS	2

ITEM NO.	DESCRIPTION	QTY.
45	.50 BMG Barrel Complete	1
46	Bolt Carrier Complete	1
47	Bolt Index Pin	1
48	Bolt Index Pin	1
49	Accelerator Spring Screw	1
50	Bolt Carrier Pin	3
51	Accelerator Spring	1
52	Bolt Extender	1
53	Accelerator	1
54	Hydraulic Recoil Buffer Assy.	1
55	Buffer Sleeve	1
56	Main Spring	1
57	Accelerator Rod	1
58	Transfer Bar Pin	1
59	Transfer Bar Detent	1
60	Transfer Bar Spring	1
61	Transfer Bar	1
62	Trigger Spring	1
63	Trigger	1
64	Disconnecter Spring	1
65	Disconnecter	1
66	Sear Spring	1
67	Sear Assembly	1

ITEM NO.	DESCRIPTION	QTY.
89	Magazine Catch Pin	1
90	Magazine Catch Spring	1
91	Mag. Catch	1
92	Mag. Floor Plate	1
93	Pistol Grip Screw	1
94	Pistol Grip Stock Washer	1
95	Pistol Grip	1
96	Safety Spring	1
97	Safety Detent	1
98	Safety	1
99	10-32 X 1.25 SHCS TORX	2
100	Monopod Rotating Foot Lower	1
101	1/8 X 3/4 Split Pin Stainless	1
102	Monopod Rotating Foot Upper	1
103	Monopod Elevation Screw	1
104	Lower Receiver Complete	1
105	Rear Grip	1
106	Monopod Lock Knob	1
107	Recoil Pad	1
108	Recoil Pad Screw	2

68	Cocking Lever	1
69	Cocking Lever Spring	1
70	Cam Pin Assembly	1
71	Yoke mount Nut	2
72	Yoke Mount Washer	2
73	Yoke Mount	2
74	Bipod Shim Bushing	2
75	Bipod Spring	2
76	Bipod Detent	2
77	Bipod Pin	2
78	Bipod Screw	2
79	Bipod Leg	2
80	RP - .125 DIA. x .625	2
81	Foot Shoe	2
82	Bipod Yoke	1
83	Midlock Pin	1
84	Rear Lock Pin	2
85	Magazine Spring	1
86	Magazine Follower	1
87	Magazine	1
88	Trigger Housing Pin	2

24	Front Sight Catch Pin	1
25	Front Sight Pin	1
26	Front Sight	1
27	Front Sight Spring	1
28	Front Sight Catch	1
29	Muzzle Brake	1
30	Muzzle Brake Screw	1
31	Muzzle Brake Shim Kit	1
32	Impact, Barrel Bumper	1
33	Battery Bumper	1
34	Hard Stop Ejector	1
35	Ejector Spring	1
36	Extractor	1
37	Extractor Plunger	1
38	Extractor Spring	1
39	Cam / Ejector Pin	2
40	Bolt	1
41	Firing Pin	1
42	Firing Pin Extension Spring	1
43	Firing Pin Extension	1
44	Firing Pin Pin	2



P.O. Box 1077
Murfreesboro, TN 37133 USA
615.896.2938
615.896.7313 fax
barrett.net