

Owner's Manual

Owner's Manual for:
Remington Genesis™ In-Line
Muzzleloading Rifle

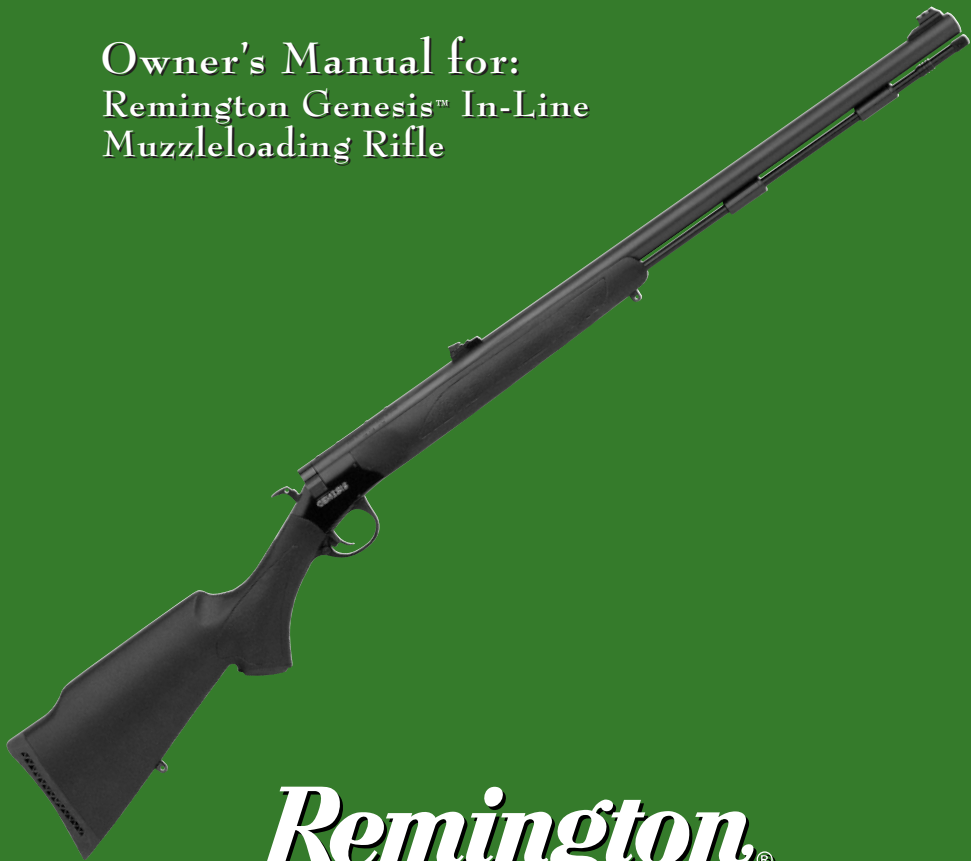

Remington®

IMPORTANT!

READ ALL WARNINGS AND
INSTRUCTIONS IN THIS
MANUAL BEFORE USING THIS SHOTGUN



PAGE 2-6THE TEN COMMANDMENTS OF FIREARM SAFETY

PAGE 7-8.....SPECIAL MUZZLELOADER SAFETY INSTRUCTIONS

PAGE 9-14IMPORTANT PARTS OF THE FIREARM

PAGE 14-23....LOADING AND SHOOTING PROCEDURES

PAGE 23-28....CLEANING INSTRUCTIONS

PAGE 28-29 ..FIELD CLEANING

PAGE 29-30 ..PARTS AND SERVICE

A Tradition of Performance and Safety.

In 1816 Eliphalet Remington was confident he could make a flintlock that was as good or better than any he could buy. His confidence was well founded. The barrel he handcrafted set a new standard for firearm accuracy and spawned generations of products that have made Remington® Arms America's leading gunmaker. While performance and style are certainly hallmarks of Remington firearms, one factor ultimately drives their performance. Safety. Eliphalet Remington never lost sight of the fact that his rifles were potentially lethal and could kill someone if handled improperly. And after more than 180 years the same holds true for any firearm, including your new Remington. Eliphalet Remington's first flintlock launched a proud tradition of accuracy and responsibility.

Safety is Critical to Performance.

A superbly crafted gun is only as good as the hands that hold it. You can never be too careful. Shooting accidents are often caused by careless oversights such as failing to control the direction of the muzzle, failing to fully engage the safety, leaving ammunition in the chamber or using improper loads. These oversights can result in the destruction of life, limb or property. There's no calling back a bullet once it's been fired, so it's critical that you know the principles of safe gun handling and storage before you ever take your new Remington firearm out of the box.

The proper use and performance of your firearm depends on correct assembly and maintenance, so it's critical that you familiarize yourself with the information in this instruction book. Even if you're a veteran shooter with a collection of Remington firearms, take the time to read this literature. Not all firearms are the same. That means the first step in safe handling is to learn the features and requirements of your new Remington.

THE TEN COMMANDMENTS OF FIREARM SAFETY

The Ten Commandments of Firearm Safety should be etched in your memory forever. Let them govern your actions wherever and whenever you're involved with firearms. In the field. On the range. Or in your home. Please take the time to review and understand these rules.

1st COMMANDMENT

Always Keep the Muzzle Pointed in a Safe Direction.

This is the most important gun safety rule. A safe direction is one in which an accidental discharge will not cause injury to yourself or others. Never allow your gun to point at anything you don't intend to shoot. Be especially careful when you're loading or unloading. Treat every gun as if it were loaded. And make it a habit to know where the muzzle is pointed at all times, even when your firearm is unloaded. No one will be injured by an accidental discharge if you keep your firearm pointed in a safe direction. It's as simple as that.

2nd COMMANDMENT

Firearms Should be Unloaded When Not in Use and Secured from Unauthorized Use.

Load your firearm only when you're in the field or on the target range and ready to fire. Never let a loaded gun out of your sight or out of your hands. Unload it as soon as you're finished shooting – before you bring it into your car, camp or home. Remember, unloading your firearm means unloading it completely, so there is no ammunition in the chamber or in the magazine. Before handling a firearm or passing it to someone else, visually check the chamber, receiver and magazine to be certain they do not contain ammunition. Always keep the gun's action open when not in use. Never assume a gun is unloaded even if you were the last person to use it. Always check for yourself.

2nd COMMANDMENT (cont'd)

Let common sense rule when you carry a loaded gun. If you're in a situation that could risk accidental discharge – such as crossing a fence, wading through a stream or climbing a tree – always unload your gun. Never pull or push a loaded firearm toward yourself or another person. And never carry a loaded gun in a scabbard, detached holster or gun case.

Certain firearms (including some Remington® rifles and shotguns) are equipped with internal security devices to prevent unauthorized use. In addition, some firearms owners use external devices, such as cable locks and trigger blocks, for the same purpose. Even if you use such a device, you should still keep your firearm unloaded when stored or not in use. And using internal or external devices cannot substitute, however, for securing your firearms and ammunition in a separate, locked location.

Safe storage of firearms is just as critical as safe handling. Never store guns loaded. Be sure to keep your firearms in a secure place where unauthorized persons cannot get their hands on them without your knowledge.

Take special care if there are children around. Kids are fascinated by guns. It's a natural curiosity that can have tragic consequences when not properly supervised. Store your firearms in a locked gun safe or some other location that physically bars a child from gaining access.

Ammunition should be stored and locked in a location separate from your firearm. Never leave an unsecured firearm or ammunition in a closet, dresser drawer or under the bed. Remember, it is your responsibility to make sure that children and others unfamiliar with firearms cannot get access to your firearm and ammunition.

3rd COMMANDMENT

Don't Rely on Your Gun's Safety.

Treat every gun as if it can fire at any time, whether or not there's pressure on the trigger. Your firearm has been carefully designed to maximize performance and safety. However, because a gun's safety is a mechanical device, it could fail.

Human error is a more likely reason for a gun safety to fail. By mistake, you may think the safety is on when it really isn't. Or the safety may have been disengaged without your knowledge. Or you could think your gun is unloaded when there's actually a cartridge or shell in it. A mechanical safety is not a substitute for common sense. It's merely a supplement to your proper handling of a firearm.

Never touch the trigger on a firearm until you are ready to shoot. Keep your fingers away from the trigger when you're loading or unloading. And don't pull the trigger when the safety is engaged or positioned between safe and fire.

Before using your gun, read this instruction book to understand the exact location and operation of your firearm's safety. Even when the safety is on, maintain control of your loaded firearm and control the direction of the muzzle. In other words, don't rely on your safety to justify careless handling. If your firearm's internal mechanisms are broken or have been altered, your firearm may fire even when the safety is on. Remember, you and your safe gun handling practices are your gun's best safety.

4th COMMANDMENT

Be Sure of Your Target and What's Beyond It.

You can't stop a shot in mid-air, so never fire unless you know exactly where your shot is going and what it will strike. Never fire at a sound, a movement or a patch of color. A hunter in camouflage can easily be mistaken for a target by an impulsive shooter. Before you pull the trigger be absolutely sure of your target and what's behind it. Make sure the shot has a backstop such as a hillside or dense material like sand. Remember, bullets can travel great distances with tremendous velocity. Know how far your shot will go if you miss your target or the bullet ricochets

Use Proper Ammunition.

Every firearm is designed to use a certain caliber or gauge of ammunition. Using the wrong ammunition, mixing ammunition or using improperly reloaded ammunition can cause serious personal injury or death. And it only takes one cartridge or shotshell of the incorrect caliber or gauge, or which has been improperly reloaded, to destroy your firearm. It's your responsibility to make sure the ammunition you use exactly matches the caliber or gauge of your gun. Refer to this instruction book to find out the specific requirements of your firearm. Always read and heed the instructions on ammunition boxes.

Confusing shells or cartridges can cause serious personal injury or death and destroy your firearm. Examine your shells or cartridges closely and use only the precise caliber or gauge for your specific firearm. For example, suppose you accidentally loaded a 20 ga. shell into a 12 ga. shotgun. Because the 20 ga. shell is too small for the chamber, the 20 ga. shell could travel down the barrel and get lodged in the bore. If you then loaded a standard 12 ga. shell behind it and fired, the 12 ga. shot will slam into the lodged 20 ga. shell and may cause the barrel to explode right in your hand. This is commonly called a 12/20 burst, and it can kill you.

Check all ammunition before you load it to make sure it matches your gun's requirements. Every Remington® cartridge and shell is head-stamped with its caliber or gauge for easy identification. Likewise, you'll find the caliber or gauge of your new Remington firearm imprinted on the barrel.

Reloading Requires Extra Diligence.

If you're an ammunition reloader you are responsible for personally assuring that the loads and components of your reloaded ammunition meet your gun's factory-tested standards. Never use ammunition which has been reloaded by someone else!

Many shooters handload as a hobby or to save money on commercial, factory-made ammunition. However, it requires a thorough knowledge of reloading procedures and a deep respect for the explosive potential of gunpowder.

Firearms are designed, manufactured and proof-tested to standards based on factory-loaded ammunition. Handloaded or reloaded ammunition that deviates, either intentionally or accidentally, from load or component recommendations can be very dangerous.

Reloaders must observe all possible safety precautions and practices related to the proper handling of explosives. Whether you're a seasoned reloader or just starting out, you should study the subject, watch reloading demonstrations and talk to experienced reloaders.

The first rule of reloading is to always follow the manufacturer's instructions for the components you're using. They'll tell you to follow certain guidelines. Namely:

1. Don't mix or substitute powders or primers.
2. Don't use unknown or substandard components.
3. Use only suitable components that have been factory-tested by reputable ammunition, powder and bullet manufacturers.
4. Always be sure to use the manufacturer's recommended recipe when reloading.

Not following these guidelines could result in severe injury to yourself or severe damage to your firearm. Dangerously high pressure and explosions can result from an overcharge of powder or other deviations from established reloading guidelines. Be very careful. The process of reloading exposes you to environmentally hazardous material. Lead, which is known to cause cancer and birth defects, is the most common substance in bullets and shot. It is important to handle lead bullets and shot with extreme care. Work only in a well ventilated area and always wash your hands after exposure and before eating. Never smoke while reloading.

Primers and powders are also highly toxic and flammable. So after reloading be sure to clean up all materials from your work area. Don't leave primer or powder spills anywhere on the floor or bench top. Dispose of all waste material in accordance with the manufacturer's recommendations.

5th COMMANDMENT (cont'd)

Finally, when reloading or handloading concentrate on what you're doing at all times. Do not be distracted by talking to others, listening to the radio or watching TV while reloading. Never reload after consuming alcoholic beverages or drugs of any kind. You are working with extremely hazardous materials and you can't risk even a few seconds of distraction. Remember, if you reload, you are the ammunition manufacturer and you are responsible for the performance and safety of your reloaded ammunition.

6th COMMANDMENT

If Your Firearm Fails to Fire When You Pull the Trigger, Handle With Care.

If for some reason the ammunition doesn't fire when you pull the trigger, stop and remember the 1st Commandment of Firearm Safety – always keep the muzzle pointed in a safe direction. Keep your face away from the breech, then put the safety on, carefully open the action, unload the firearm and dispose of the cartridge safely. Remember that anytime there's a shell in the chamber, your gun is loaded and ready to use. Even if you tried to shoot and your gun didn't fire, treat your firearm as if it could still discharge.

7th COMMANDMENT

Always Wear Eye and Ear Protection.

Your sight and hearing risk injury from shooting and should be protected at all times. Wear protective shooting glasses to guard against falling shot, clay target chips, powder residue, ruptured cartridge cases and even twigs and branches in the field. Also be sure to wear eye protection when you're disassembling or cleaning a gun so that tensioned parts (like springs) and cleaning solvents don't come in contact with your eyes. Continued exposure to shooting noise can permanently damage your hearing. On the range, where shooting volume is the loudest, be sure to use the maximum protection of a headset. And learn to use ear protection in the field, especially in confined locations like duck blinds.

8th COMMANDMENT

Be Sure the Barrel is Clear of Obstructions Before Shooting.

Before loading your gun, open the action and make sure there's no ammunition in the chamber or magazine. Check the barrel for any obstructions or debris. Even a small amount of snow, mud, excess lubricant or grease in the bore can dangerously increase pressure and cause the barrel to bulge or burst when firing. Use a cleaning rod and patch to wipe away anti-rust compounds or any other residues or obstructions in the barrel. Never try to shoot out an obstruction by loading another shell and firing!

When firing rely on your instincts. If the noise or recoil of your firearm seems weak, stop everything, unload your firearm and be sure nothing is lodged in the barrel. Remember the 12/20 burst? That's what can happen when the barrel is obstructed. So always be sure you're using the correct ammunition in your firearm and that it's free of obstructions.

9th COMMANDMENT

Don't Alter or Modify Your Gun and Have it Serviced Regularly.

Your firearm has been designed to operate according to certain factory specifications. You'll jeopardize your safety and that of others around you by attempting to alter its trigger, mechanical safety or other mechanisms. So never alter or modify your firearm in any way.

Like any mechanical device, a firearm is subject to wear. It must be maintained and periodically serviced to assure optimum safety and performance. Only a qualified service facility should service, repair or modify your Remington® firearm. Consult your instruction book for instructions on how to send your firearm to the factory or for the location of the nearest Remington repair station.

Proper cleaning and lubrication are also important to firearm maintenance and are necessary to assure accuracy, safety and reliability. Before cleaning, always make sure that your gun is completely unloaded. And always clean the barrel from the chamber end to the muzzle when possible.

Make it a practice to clean your bore every time you're going to shoot. Be sure to clean your entire gun before and after long-term storage and no less than once a year. It's also important to clean your gun whenever it's been exposed to adverse conditions such as rain, dirt, mud, snow, sleet or saltwater.

For safe and dependable operation of your firearm, all parts of your gun must be properly cleaned and lubricated. Periodically inspect the internal workings of your firearm to be sure they're clean and free of rust, unwanted dirt and debris.

Use recommended lubricants on your gun and do not over-lubricate. Excessive use of a non-recommended lubricant could adversely affect the function and safe operation of your firearm. Remember, you are responsible for the proper care and maintenance of your firearm. Failure to properly maintain your firearm can not only damage or ruin your firearm, it can expose you and others to unnecessary risks of personal injury or death.

Remington® has a wide range of firearm care products and resources for best results when cleaning your gun. Everything from solvents and lubricants to rods and patches. They're all available from your Remington dealer.

10th COMMANDMENT

Learn the Mechanics and Handling Characteristics of Your Firearm.

Not all firearms are alike. They have different mechanical characteristics that dictate how you should carry and handle them. Anyone who plans to use a firearm should first become totally familiar with the type of firearm it is and the safe handling procedures for loading, unloading, carrying, shooting and storing it.

Before you even unpack your new Remington firearm, read this instruction book from cover to cover and familiarize yourself with the different component parts of the gun. Then read, understand and follow the Ten Commandments of Firearm Safety in this book.

LEAD EXPOSURE WARNING

Discharging firearms in poorly ventilated areas, cleaning firearms or handling ammunition may result in exposure to lead, a substance known to cause birth defects, reproductive harm, cancer and other serious physical injury. Have adequate ventilation at all times. Wash hands thoroughly after exposure.

SHOOT SOBER!!

There's one other rule that must be followed when handling firearms. In fact, respect for this rule is necessary in order to effectively practice the Ten Commandments of Firearm Safety. The rule is: SHOOT SOBER! Guns and alcohol or drugs make a deadly combination. Never consume anything that would mildly impair your judgment or physical coordination when you're using a firearm. A staggering percentage of the shooting accidents that occur every year involve alcohol or drugs. Be smart. Always shoot sober and stay alive.

WARNING

Failure to follow any of these safety rules may cause personal injury or death to the shooter or bystander and damage to property. Do not use a firearm until you fully understand and practice the Ten Commandments of Firearm Safety. If you have any questions about the safe use of a Remington firearm, write to us at Remington Arms Company, Inc., Consumer Service, P.O. Box 700, Madison, NC 27025-0700, or call us at 1-800-243-9700.

SPECIAL SAFETY RULES FOR MUZZLELOADERS

In addition to the Ten Commandments of Firearm Safety, there are several guidelines specific to black powder guns that muzzleloaders must observe at all times to ensure their safety and the safety of others. The following is a brief overview of these guidelines. For full details, thoroughly read this instruction book.

MUZZLELOADING SAFETY RULES

1. **NEVER** smoke while using your muzzleloader or while near any quantity of black powder, PYRODEX[®] or Triple Seven[®].
2. **BEFORE LOADING, MAKE SURE THE FIREARM IS NOT ALREADY LOADED.** To make sure it is unloaded, insert the ramrod provided with the rifle into the bore to the breech plug and note its position at the muzzle. It should be approximately 1/4 inch below flush with the end of the barrel if the rifle is not loaded. **NOTE: Nothing can be attached to the ramrod while using it in this way. USE ONLY THE RAMROD PROVIDED.**
3. **ALWAYS CHECK AND CLEAR THE FLASH HOLE THROUGH THE BREECH PLUG BEFORE SHOOTING. ALWAYS CHECK THE BARREL FOR OBSTRUCTIONS BEFORE LOADING AND SHOOTING.** Before checking for an obstruction, put the safety mechanism in the 'SAFE' position (RED BAND WILL NOT SHOW) and remove the 209 primer and residue from the breech plug. Water, snow, mud or any other material can obstruct the barrel and cause barrel damage.
4. **USE BLACK POWDER, PYRODEX[®] OR TRIPLE SEVEN[®] ONLY TO LOAD YOUR MUZZLELOADING FIREARM.** Never use even small amounts of smokeless powder, even if it is black in color. The use of any other propellant may cause injury or death to the shooter or bystanders and damage the firearm.
5. **NEVER EXCEED THE MAXIMUM RECOMMENDED POWDER CHARGE CONTAINED IN THIS BOOK.** To do so could result in injury or death to the shooter or bystanders.
6. **NEVER POUR POWDER DIRECTLY FROM A POWDER FLASK OR CONTAINER.** A sudden powder ignition from a lingering spark could cause the entire flask to explode. Use an individual charge from a powder measure when loading your rifle. Read and follow your powder manufacturer's procedures for powder storage.
7. **NEVER USE THE WRONG AMMUNITION COMPONENTS.** Only use ammunition components that exactly match the caliber markings on your firearm and are meant to be used together. Use only pure lead components when shooting lubed conical bullets. Do not use any other lead alloys with lubed conical bullets as they may be too hard for proper and safe use in your muzzleloader.
8. **WHEN LOADING, BE CERTAIN POWDER, PATCHES AND PROJECTILES ARE IN THEIR PROPER SEQUENCE AND THAT THEY ARE COMPLETELY SEATED AGAINST ONE ANOTHER.** Serious personal injury or death can result if space is left between them. To provide a reference mark for future loadings, mark the ramrod at the muzzle once a projectile has been loaded to the proper depth. **NOTE:** Be sure to recheck the ramrod mark if you change loading components or alter the ramrod. See Picture 16 on page 18. Never attempt to shoot out a projectile that is not firmly seated against the powder charge or does not seat to the proper depth. Remove these projectiles following the instructions on pages 21 and 22.
9. **ALWAYS USE COTTON PATCHING.** The use of non-cotton patching could build up a static electric charge possibly creating a spark that could ignite the powder.
10. **NEVER POUND THE RAMROD.** Muzzleloading propellants are impact sensitive and could ignite from impact. Keep the ramrod directly away from your face or body.
11. **KNOW THE RANGE OF YOUR FIREARM.** Muzzleloading projectiles have a range of more than one-half mile.
12. **IF THE FIREARM FAILS TO FIRE, BE PREPARED FOR A HANGFIRE.** Keep the muzzle pointed in a safe direction and wait no less than one full minute before opening the bolt. A spark may have reached the powder without any sound. The rifle could fire at any moment during this minute. If the rifle does not fire within a minute, carefully follow the directions on how to handle a misfire on page 19.

SPECIAL SAFETY RULES FOR MUZZLELOADERS (cont'd)

MUZZLELOADING SAFETY RULES

13. **RENDER YOUR FIREARM INOPERABLE WHENEVER YOU ARE NOT SHOOTING.** Never place the primer into the breech plug until just before firing and remove it immediately if you do not fire. Never carry or store a loaded firearm in a building or a vehicle. Unload it by firing it into a suitable backstop before returning to your vehicle, entering a building, crossing or climbing up or down any obstacle that may prevent you from keeping full control over the firearm, such as a fallen tree, fence, tree stand or slippery area. Failure to follow this rule may cause serious injury or death to the shooter or bystanders.
14. **BLACK POWDER LEAVES HEAVY CORROSIVE RESIDUES.** A thorough cleaning and lubing are absolute necessities before storage and prior to loading and shooting. Follow the cleaning instructions starting on page 23. Always carry loading and cleaning equipment with you in the field.
15. **WARNING:** Discharging firearms in poorly ventilated areas, cleaning firearms or handling ammunition components may result in exposure to lead, a substance known to cause birth defects, reproductive harm, cancer and other serious physical injury. Have adequate ventilation at all times. Wash hands thoroughly after exposure. **WARNING:** Failure to follow any of these muzzleloading safety rules may cause personal injury or death to the shooter or bystander and damage to property. Do not use a muzzleloading firearm until you fully understand and practice the Ten Commandments of Firearm Safety and the safety guidelines specific to muzzleloader shooting, to your muzzleloading firearm and to your muzzleloading ammunition components. If you are unfamiliar with muzzleloading firearms, seek professional instruction from a qualified organization such as the International Black Powder Hunting Association, National Muzzleloading Rifle Association, National Rifle Association or your State Hunter Safety program. If you have any questions about the safe use of a Remington® black powder firearm, write to us at Remington Arms Company, Inc., Consumer Services, P.O. Box 700, Madison, NC 27025-0700 or call us at 1-800-243-9700.

DON'T KEEP THIS TO YOURSELF.

Now that you're a gun owner you have the obligation to help ensure that shooting sports are safe for everyone – participants and bystanders alike. You can do that by practicing these principles of firearm safety and passing them on to others – especially new shooters. Set an example for beginners. Be a guide to their safe entry into the exciting world of shooting sports. Invest your time and patience for the love of the sport and for its future. After all, it's your love of the sport that led you to buy a new Remington.

Firearm ownership ownership is a right and privilege. It's a right guaranteed in this nation's Constitution. It's a privilege which carries with it a personal responsibility to use your firearm in a way which will ensure your safety and the safety of others. The preservation of this right and privilege depends on the personal commitment of you and your fellow shooters to the safe and responsible use of firearms. Let the Ten Commandments of Firearm Safety outlined in the book guide you at all times. Teach and promote these rules whenever you can. Remember, firearm safety depends on you! That's the only way to really enjoy your new Remington firearm and to preserve sport shooting as we know it today.

Remington Genesis™ ML In-Line Muzzleloading Rifle

Congratulations on your choice of a Remington Genesis In-Line Muzzleloading rifle. With proper care, it should give you many years of dependable use and enjoyment.

Firearm Safety

*A person using a firearm has assumed an enormous responsibility. You must use your firearm in a way that will ensure not only your own safety, but that of others. Safe firearm handling is not a part-time or occasional requirement – it is a full-time responsibility. You **must** know how to use your firearm safely at **all** times under **all** circumstances. **Never** use any firearm without a complete understanding of how it works and how to use it safely.*

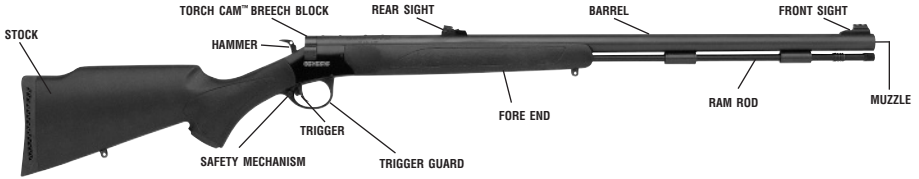

This picture shows the main parts of a Remington Genesis In-Line Muzzleloading Rifle. The picture will aid in understanding the instructions in this book.

This instruction book is intended to help you learn how to properly and safely use and care for your Remington® firearm. Only when you understand and can safely practice all of the instructions in this book, should you begin to use the firearm with live ammunition. If you are unfamiliar with muzzleloading firearms, seek professional instruction from a qualified organization such as the International Black Powder Hunting Association, National Muzzleloading Rifle Association, National Rifle Association or your State Hunter Safety program.

If you loan or sell this firearm, this book must accompany the firearm.

Replacement books are available from Remington at no charge.

If you have any questions concerning the safe use of your Remington firearm, write to us at Remington Arms Company, Inc., Consumer Services, P.O. Box 700, Madison, NC 27025-0700.

Important Parts of the Firearm

The Safety Mechanism. The safety mechanism on the Remington Genesis ML muzzleloading rifle is a button located on the trigger guard behind the trigger. The safety mechanism blocks the trigger when engaged in the 'SAFE' position. The safety mechanism provides protection against accidental or unintentional discharge under normal usage when properly engaged and in good working order. The safety mechanism is not a substitute for following the rules of safe gun handling.

To engage the safety mechanism, push the button so that the **RED BAND MARKING CANNOT BE SEEN**.

(See **Picture 2**). Always put the safety mechanism in the 'SAFE' position before handling, loading or unloading the firearm.



Picture 2

Important Parts of the Firearm (cont'd)

The Safety Mechanism. When you are ready to fire the firearm, push the safety mechanism button so that the **RED BAND IS SHOWING** forward to disengage the safety mechanism. The hammer may now be cocked in order to fire the firearm. (See **Picture 3**).

Do not touch the trigger while moving the safety mechanism. Your fingers and all other objects should be kept outside of the trigger guard and away from the trigger until you are actually ready to fire by pulling the trigger.



Picture 3

WARNING

The firearm will fire when the trigger is pulled and the **RED BAND IS SHOWING** if the hammer is cocked. Never pull the trigger when the safety mechanism is in the 'SAFE' position. Even when you think the safety mechanism is in the 'SAFE' position, careless handling can cause the firearm to fire. SEE THE TEN COMMANDMENTS OF FIREARM SAFETY ON PAGES 2-6.

The Hammer Mechanism. The Genesis ML inline muzzleloading rifle is equipped with an external hammer. The hammer must be cocked in order to fire the firearm. An ambidextrous hammer spur is included with the rifle to aid in cocking the hammer, especially when used with telescopic sights. Install the hammer spur by screwing it into either the right or left side of the hammer.

The Trigger Assembly. Pulling the trigger fires the firearm. The trigger is adjusted at the factory. Never attempt to alter the trigger or trigger assembly.

WARNING

NEVER put your finger on the trigger unless you are going to fire the firearm.

The Barrel. The barrel of your rifle has a rust preventative compound applied at the factory to protect the metal during shipment. Before shooting your rifle for the first time, you must clean the anti-rust compound from the barrel and breech plug. To clean the barrel, refer to the Cleaning Instructions on pages 23 and 24.

The inside of the barrel must be clean and free of obstructions.

I. TO CHECK THE INSIDE OF THE BARREL:

1. Point the firearm in a safe direction.
2. Put the safety mechanism in the 'SAFE' position.
3. Check to be sure there is no primer or primer residue in the breech plug primer pocket and there is no charge in the barrel. See instructions on using the ramrod to check for a charge in the barrel on page 7.

WARNING

If there is a charge in the barrel, do not attempt to remove it by shooting it out if you are unsure what the charge is or if you are unsure if the charge is safe. Instead, remove the charge using the instructions on pages 21 and 22.

Important Parts of the Firearm (cont'd)

The Barrel.

4. Remove the breech plug. See instructions on page 13.
5. Look through the inside of the barrel from the breech end to the muzzle. (See **Picture 4**).



Picture 4

II. TO REMOVE OBJECT FROM INSIDE THE BARREL:

(To remove a charge, see REMOVING A CHARGE on pages 21 and 22.)

1. Use the ramrod with an extension, or a cleaning rod designed for use with rifled bores.
2. With the breech plug removed, remove the powder charge and push the ramrod or cleaning rod through the barrel from the breech end to the muzzle to remove the object.
3. If an object cannot be easily pushed out of the barrel with a ramrod or cleaning rod, contact the Remington service center listed on page 29 of this owner's manual.

WARNING

NEVER try to remove an object from the barrel by firing it out. This may cause serious damage to the firearm and injury or death to the shooter or bystanders.

III. TO CLEAN THE BARREL FOLLOW THE INSTRUCTIONS SHOWN ON PAGES 23 AND 24.

Before loading the firearm, make sure the inside of the barrel is free of dirt or other obstructions.

The Torch Cam™ Breech Block.

The Torch Cam™ breech block is located in front of the hammer mechanism. (See **Picture 5**). The Torch Cam™ breech block opens from the shooter's right to expose the breech plug. The Torch Cam™ breech block contains the firing pin and must be locked into the closed position to cover the primed breech plug in order to fire the rifle.



Picture 5

Important Parts of the Firearm (cont'd)

The Torch Cam™ Breech Block.

TO OPEN THE TORCH CAM™ BREECH BLOCK

1. Grasp the firearm with your left hand beneath the receiver. (See **Picture 6**).
2. Lift the Torch Cam™ breech block up with your right hand and swing the breech block counter clockwise to the shooter's left side of the firearm. (See **Picture 7**).
3. The breech plug is now visible and accessible for priming



Picture 6



Picture 7

TO CLOSE THE TORCH CAM™ BREECH BLOCK

1. Grasp the firearm with your left hand beneath the receiver. (See **Picture 6**).
2. Rotate the Torch Cam™ breech block clockwise toward the shooter's right side of the firearm. (See **Picture 8**).
3. Press down firmly on the grooved edge of the Torch Cam™ breech block to lock it into place. (See **Picture 9**). You should hear an audible click and feel the detent ball lock into place. The Torch Cam™ breech block must be locked into place to fire the firearm.



Picture 8



Picture 9

The Breech Plug.

The breech plug holds the 209 primer used to ignite the powder charge. The breech plug is located at the rear of the barrel and is exposed by opening the Torch Cam™ breech block. (See **Picture 10**).

The breech plug is installed at the factory but should be removed and thoroughly cleaned along with the barrel prior to firing the muzzle loading rifle for the first time in order to remove any residual rust preventives applied at the factory. To remove the breech plug, follow the instructions below. To clean the barrel, follow the instructions listed on pages 23 and 24.



Picture 10

Important Parts of the Firearm (cont'd)

To Remove The Breech Plug.



WARNING

Never attempt to remove the breech plug with a primer in the primer pocket.

1. Point the firearm in a safe direction and insure that the safety mechanism is in the 'SAFE' position.
2. Open the Torch Cam™ breech block by following the instructions on page 12.
3. With the Torch Cam™ breech block open, inspect the breech plug to insure no primer or primer residue remaining in the breech plug primer pocket, and there is no charge in the barrel. See instructions on using the ramrod to check for a charge in the barrel on page 7.



WARNING

If there is a charge in the barrel, do not attempt to remove it by shooting it out if you are unsure what the charge is or if you are unsure if the charge is safe. Instead, remove the charge using the instructions on pages 21 and 22.

4. Disengage the safety mechanism and cock the hammer.
5. Return the safety mechanism to the 'SAFE' position.
6. Use the breech plug wrench provided to remove the breech plug from the barrel. (See **Picture 11**). (Note: The breech plug may be difficult to remove after firing. To remove a stuck breech plug, first try to actually tighten the breech plug and then rock the wrench back and forth to attempt to loosen the breech plug.)
7. If the breech plug can not be removed with reasonable force using the breech plug wrench provided, contact the Remington Service Center listed on page 29 of this Owner's Manual.



Picture 11

To Install The Breech Plug.



WARNING

Never attempt to install the breech plug with a primer in the primer pocket.

1. With nothing in the barrel and a clean breech plug, apply Remington breech plug grease sparingly onto the breech plug threads. This will aid in preventing the breech plug from becoming stuck after prolonged periods of storage or after firing your muzzle loading rifle. Avoid putting grease on the front face of the breech plug. This will foul the powder that comes in contact with it, increasing the chances of a misfire or hang fire.
2. Open the Torch Cam™ breech block to expose the threaded end of the barrel.

Important Parts of the Firearm (cont'd)

To Install The Breech Plug.

3. With the hammer cocked and the safety mechanism in the 'SAFE' position, place the breech plug in the threaded rear opening of the barrel. (See **Picture 12**).



Picture 12

4. Use the breech plug wrench provided to thread the breech plug into the rear of the barrel. Start it by hand at first to ensure it is not cross threaded.
5. Make sure the breech plug is tightened snugly and the back face of the breech plug is seated slightly below the rear edge of the barrel. Do not over-tighten.

⚠ WARNING

THE BREECH PLUG MUST BE SEATED CORRECTLY IN THE BARREL TO ENSURE THE PROPER AND SAFE OPERATION OF THE FIREARM. DO NOT ATTEMPT TO FIRE THE RIFLE if the breech plug will not thread in smoothly and tighten snugly with the BACK FACE of the breech plug seated slightly below the REAR EDGE of the barrel. If the breech plug cannot be seated correctly, contact the Remington Service Center listed on Page 29 of this Owner's Manual.

Loading and Shooting Procedures

Use Black Powder, PYRODEX® or Triple Seven® Only

Never use modern smokeless gun powder even if it is black in color. Never use any powder other than black powder PYRODEX® or Triple Seven in this muzzleloader. The use of any other propellant will cause serious injury or death to the shooter and bystanders and damage to the firearm.

Prior to loading and shooting the firearm, refer to the cleaning instructions starting on page 23.

It is essential your gun is clean for proper safety, function and accuracy.

Black Powder, PYRODEX® and Triple Seven®

Black powder is the name that identifies the type of powder that is safe to use in muzzleloading firearms and DOES NOT REFER TO ALL POWDERS THAT ARE BLACK IN COLOR. Some modern smokeless powders are black in color but are designed to be used only in modern centerfire cartridges and shotgun shells. Be sure to identify the powder as a type to be used in muzzleloading firearms by the name and NOT THE COLOR. PYRODEX® and Triple Seven® are black powder replicas that are intended for use in percussion type muzzleloading firearms and are the ONLY black powder replicas that are safe to use in this Remington® Genesis™ ML Muzzleloading rifle.

PYRODEX® Powder is intended to be used as a volume-to-volume replacement for black powder and will produce similar velocities and pressures as the same volume of the appropriate granulation of black powder. Thus, a volumetric powder measure that is set to measure 100 grains of black powder can be filled with PYRODEX® or instead to achieve similar results. PYRODEX® is used on a volume-to-volume replacement basis and NOT ON A WEIGHT-TO-WEIGHT BASIS.

Loading and Shooting Procedures (cont'd)

⚠ WARNING! TRIPLE SEVEN® Powder is NOT intended to be used as a volume-to-volume replacement for black powder or PYRODEX®. To obtain similar velocities and pressures as black powder or Pyrodex® powder, you must decrease the volume of Triple Seven® powder by 15%. Thus, on a volumetric basis, to replicate the same pressure and velocity of a 100 grain black powder or Pyrodex® load, you must calibrate your volumetric powder measure to 85 grains for Triple Seven®.

⚠ WARNING! The use of ANY quantity of smokeless gun powder in this muzzleloading firearm will produce dangerously high pressures which WILL result in serious injury or death to the shooter and bystanders, and damage to the firearm.

*Black powder is available in four powder grain sizes which are identified by a series of 'F's' marked on the container. 2F or FFG is used in .45 caliber or larger guns. **This is the granulation recommended for use in this muzzleloading rifle. Do not use any other granulation.***

PYRODEX® is available in two grain sizes identified by an 'RS' or 'P' on the container.

PYRODEX® RS – Stands for Rifle and Shotgun powder and is designed for use in all calibers of percussion type muzzleloading rifles and shotguns. **PYRODEX® RS is recommended for use in this muzzleloading rifle. Do not use PYRODEX® P or any other designation.**

Triple Seven® FFG is designed for use in all calibers of percussion type muzzleloading rifles and shotguns. TRIPLE SEVEN® FFG is recommended for use in this muzzleloading rifle.

⚠ WARNING! ONLY 2F OR FFG Black Powder, PYRODEX® RS, or TRIPLE SEVEN® FFG should be used in this rifle.

This muzzleloading rifle is designated for use with a maximum powder charge of 150 grains of FFG Black Powder, Pyrodex® RS loose powder or 130 grains Triple Seven® FFG loose powder.

Pelletized Propellants

Pyrodex® and Triple Seven® propellants are available in either 30 grain or 50 grain pre-measured pellet form and are intended to produce similar velocities and pressures as the same volume of the appropriate granulation of black powder or Pyrodex®. Thus, two 50 grain Pyrodex® or Triple Seven® pellets will produce pressures and velocities equivalent to a charge of 100 grains of black powder or Pyrodex® powder.

This muzzleloading rifle is designated for use with a maximum three (3) 50 grain pellet propellant charge of Pyrodex® or Triple Seven® 50 caliber pellets.

⚠ WARNING! Never exceed the maximum powder charge for this muzzleloading rifle. Failure to comply with any of these warnings could result in serious personal injury or death to the shooter or bystanders and damage to the firearm.

Selecting the Projectile.

Note: Only use projectiles designated for use in muzzleloading firearms.

There are three projectile types that can be fired safely and accurately in this rifle. They are the sabot conical, the lubed conical and the patched round ball.

(See **Picture 13**).



Picture 13

Loading and Shooting Procedures (cont'd)

The Saboted Conical.

With a sabot projectile, the sabot engages the barrel rifling (rather than the projectile itself) to provide a gas seal as well as to provide the rotation necessary to stabilize the projectile in flight. A smaller-than-bore-size projectile can be used with a sabot resulting in higher muzzle velocity, flatter trajectory. The sabot is self-lubricating, so there is no need to use additional lubrication when shooting sabot projectiles. Never use a patch with conical projectile that is to be used with a sabot.



The Lubed Conical.

With the lubed conical, the projectile itself engages the rifling to provide a gas seal as well as the rotation necessary to stabilize the projectile in flight. Never use a patch or sabot with a lubed conical projectile. Always use lubricant with any projectile that is not to be used with a sabot.



The Patched Round Ball.

With a patched round ball, the lubed cloth patch serves the same purpose as the sabot does with the sabot conical projectile type. It engages the rifling to provide a gas seal as well as the rotation necessary to stabilize the ball in flight.



WARNING

The patch should be well lubricated and made of cotton to avoid building a static electric charge in the barrel as the projectile is being seated on the powder charge. A non-cotton patch could create a spark and ignite the powder charge causing serious injury or death to the shooter or bystanders.

Never use a jacketed bullet without a sabot in this muzzleloading rifle. Only pure lead lubed projectiles, specifically designed for muzzleloading, are meant to be used without a sabot. Never use a sabot with a round ball. The sabot is not designed for a round ball and could easily separate from the powder charge creating a dangerous air gap. Be absolutely certain that loading components are used only as they were intended to be used and are properly used together.

Loading the Powder and Projectile.

WARNING! Before Loading Make Sure:

1. The firearm is in good working order.
2. The firearm is pointed in a safe direction.
3. The safety mechanism is in the 'Safe' position. See page 9.
4. The Torch Cam™ breech block is in the open position. See page 12.
5. There is no primer in the primer pocket of the breech plug or primer residue on the breech plug.
6. The firearm is not already loaded. See page 7.
7. The barrel is free from obstructions. See page 10.
8. The breech plug is properly seated in the barrel. See pages 12, 13 and 14.
9. The flash hole through the breech plug is clear.
10. You are wearing ear and eye protection.
11. You are in a place that is safe to shoot.
12. You are using only the correct loading components for this rifle.

Loading and Shooting Procedures (cont'd)

I. LOADING THE POWDER:

WARNING

Do not attempt to load the firearm until you have read and understand this book in its entirety and all 12 of the previous loading conditions listed above have been met.

1. Using the ramrod with extension and cleaning jag or a cleaning rod, swab the bore to the breech plug with a cleaning patch that has been saturated with Remington 40-X™ Bore Cleaner or a Remington Express Clean patch to remove any debris or fouling that may have accumulated in the bore while the rifle was in storage.
2. Using the same method, swab a dry patch through the bore.
3. Repeat steps 1-2 until the dry patch comes out clean.
4. Point the firearm in a safe direction and fire at least two primers to make sure the flash hole through the breech plug is clear and dry. Residual bore cleaner at the breech could saturate the powder and increase the possibility of a misfire or hang fire.

WARNING

Wait at least one full minute after firing the last round or primer before pouring powder or placing pellets into the bore to allow time for any residual sparks to be extinguished.

5. Place the butt of the rifle on a firm, stable surface with the muzzle pointed up and well away from your body.

Treat the firearm as if it could go off at any time.

WARNING

Make sure you are using 2F or FFg black powder, PYRODEX® RS or Triple Seven® FFG only. Never use ANY quantity of any other powder. Never pour powder directly into the muzzle from a powder flask or container. A lingering spark could ignite the entire container of powder. Always use an individual charge measure. Never exceed the maximum charge listed on page 15.

NEVER USE CENTERFIRE POWDER CHARGING EQUIPMENT FOR MUZZLELOADERS

6. Keep the muzzle pointed up and away from your body at all times to keep the powder in the bottom of the barrel and to avoid accidents or injuries.
7. Proceed to load the projectile.

II. LOADING THE PROJECTILE:

WARNING

Do not attempt to load the firearm until you have read and understand this book in its entirety and all 12 of the loading conditions listed previously under "BEFORE LOADING MAKE SURE" on page 16.

1. Keep the butt of the rifle on a firm, stable surface with the muzzle pointed up and away from your body.
2. If you choose to use a lubricated wad, place it evenly on the muzzle so it plugs the entire bore. Push the wad into the bore a short distance with a short starter
3. Load ONE of the projectiles as follows:

- To load a Saboted Conical, firmly seat the projectile in the sabot and push the sabot and projectile into the bore by hand. (See **Picture 14**).
- To load a Lubed Conical, push the lubricated projectile by hand into the bore. (See **Picture 14**).
- To load a Patched Round Ball, lay a lubricated patch evenly over the muzzle and push a round ball into the center of the patch and into the bore by hand. (See **Picture 14**).

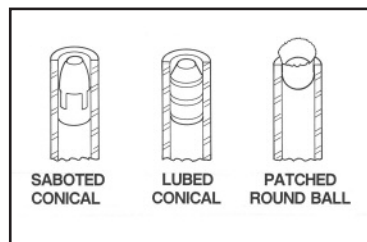

Picture 14

Loading and Shooting Procedures (cont'd)

II. LOADING THE PROJECTILE:

4. Use the ball end of a short starter to start the projectile and align it with the bore. Push the projectile approximately six inches into the bore with the shaft of the short starter.
5. Use the ramrod to seat the projectile (and lubricated wad if used) firmly on the powder charge. (See **Picture 15**).



Picture 15

WARNING

Do not pound on the ramrod to seat the projectile. Black Powder, PYRODEX®, and Triple Seven® are impact sensitive and may ignite from impact. The impact may also deform the projectile, adversely affecting accuracy.

6. Be sure the projectile is firmly seated on the powdercharge so there isn't a gap between the powder and the projectile. To provide a reference mark for future loadings, mark the ramrod at the muzzle once a projectile has been loaded to the proper depth. (See **Picture 16**).

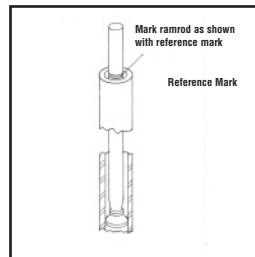

Picture 16

Note: Be sure to recheck the ramrod mark if you change loading components or alter the ramrod.

7. Remove the ramrod from the barrel and replace it in the fore end under the barrel.

III. PLACING THE 209 PRIMER:

NOTE: Only use 209 Shotgun primers. For optimum performance use Remington KLEENBORE® primers for muzzleloading firearms

1. With the muzzle pointed in a safe direction, open the Torch Cam™ breech block to expose the breech plug.
2. Locate the primer pocket in the center of the breech plug (See **Picture 17**).
3. Inspect the primer pocket thoroughly to insure that it is free of debris and that the flash hole is clear of obstructions.
4. Place one 209 primer into the primer pocket located in the center of the breech plug. The primer should fit easily in the primer pocket without being forced into place.
5. To close the Torch Cam™ breech block, rotate the Torch Cam breech block clockwise toward the shooter's right side of the firearm. See Picture 8.
6. Press down firmly on the grooved edge of the Torch Cam™ breech block to lock it into place. See Picture 9. You should hear an audible click and feel the detent ball lock into place. The Torch Cam™ breech block must be locked into place to fire the firearm.



Picture 17

Loading and Shooting Procedures (cont'd)

NOW THE RIFLE IS LOADED.

To make the rifle ready to fire, put the safety mechanism in the 'Fire' position and cock the hammer.

NOW THE RIFLE IS READY TO FIRE.

Pulling the trigger fires the rifle.



WARNING

Wait at least one full minute after firing the last round before pouring powder into the bore to allow time for any residual sparks to be extinguished.

How to Handle a Misfire and Hang Fire.

The Remington Genesis™ ML has been designed to fire the instant that you pull the trigger. If, however, the powder and/or 209 primer are damp, a hang fire or misfire may occur. A hang fire occurs when the rifle fires up to several seconds after the trigger is pulled. A misfire occurs when a loaded rifle does not fire when the trigger is pulled.

In the case of a misfire or hang fire, proceed as follows:

1. Keep the rifle pointed in a safe direction for at least one full minute with the hammer in the uncocked position.

BE PREPARED FOR THE RIFLE TO FIRE AT ANY INSTANT.

2. After no less than one minute return the safety mechanism to the 'Safe' position. See page 9.
3. Open the Torch Cam™ breech block to expose the breech plug.
4. Remove the 209 primer from the primer pocket and use a nipple pick to ensure that the flash hole through the primer pocket is clear.
5. Place a new 209 primer in the primer pocket.
6. Close the Torch Cam™ breech block.
7. Aim at the target.
8. Put the safety mechanism in the 'Fire' position, cock the hammer and fire.
9. If the rifle still does not fire, repeat steps 1 through 8 several more times.
10. If the rifle still does not fire, the charge must be removed manually. See REMOVING A CHARGE on page 21.

Suggested Loading Data.

This data was compiled from testing done by Remington® Arms using .50 caliber projectiles in a muzzleloading rifle with a 1 in 28" twist. All testing was done with 2F or FFg black powder. This data is intended to serve as a guideline only. Actual ballistic performance may vary based upon the type and brand of projectile used.



WARNING

NEVER EXCEED THE MAXIMUM CHARGE LISTED FOR USE IN THE REMINGTON GENESIS ML IN-LINE MUZZLELOADING RIFLE. SEE PAGE 15. ONLY USE PROPELLANTS APPROVED FOR USE IN THE REMINGTON GENESIS ML IN-LINE MUZZLELOADING RIFLE. SEE PAGE 15.

Failing to adhere to the maximum charge or substituting any powder type or granulation could result in serious personal injury or death to the shooter or bystanders and damage to the firearm. The charge criteria listed are the nominal range charge criteria for the given projectile.

The nominal suggested range of charge criteria produces the best combination of accuracy and velocity. It is done by starting at the lower charge listed in the nominal range and increasing in 5 to 10 grain increments until an optimum load is achieved. An optimum load is one which produces the best accuracy.



WARNING

Do not exceed the charge specified on Page 15. To do so may result in serious personal injury or death to the shooter or bystanders and damage to the firearm.

Loading and Shooting Procedures (cont'd)

Suggested Loading Data.

.50 CALIBER SABOTED PROJECTILES

Jacketed Hollow Point - 275 grains

Powder Charge	Muzzle Velocity	Muzzle Energy
90 grs.	FFg 1450 f.p.s.	1284 ft.-lbs.
100 grs.	FFg 1505 f.p.s.	1383 ft.-lbs.
110 grs.	FFg 1565 f.p.s.	1495 ft.-lbs.
120 grs.	FFg 1610 f.p.s.	1583 ft.-lbs.

Solid- 289 grains

Powder Charge	Muzzle Velocity	Muzzle Energy
90 grs.	FFg 1450 f.p.s.	1384 ft.-lbs.
100 grs.	FFg 1515 f.p.s.	1471 ft.-lbs.
110 grs.	FFg 1563 f.p.s.	1566 ft.-lbs.
120 grs.	FFg 1635 f.p.s.	1658 ft.-lbs.

Jacketed Hollow Point - 303 grains

Powder Charge	Muzzle Velocity	Muzzle Energy
90 grs.	FFg 1397 f.p.s.	1313 ft.-lbs.
100 grs.	FFg 1480 f.p.s.	1474 ft.-lbs.
110 grs.	FFg 1515 f.p.s.	1544 ft.-lbs.
120 grs.	FFg 1570 f.p.s.	1658 ft.-lbs.

.50 CALIBER LEAD LUBED CONICLES

Flat Base Hollow Point - 365 grains

Powder Charge	Muzzle Velocity	Muzzle Energy
90 grs.	FFg 1350 f.p.s.	1477 ft.-lbs.
100 grs.	FFg 1405 f.p.s.	1600 ft.-lbs.
110 grs.	FFg 1470 f.p.s.	1751 ft.-lbs.
120 grs.	FFg 1525 f.p.s.	1885 ft.-lbs.

Flat Base Solid Point- 385 grains

Powder Charge	Muzzle Velocity	Muzzle Energy
90 grs.	FFg 1315 f.p.s.	1479 ft.-lbs.
100 grs.	FFg 1370 f.p.s.	1605 ft.-lbs.
110 grs.	FFg 1435 f.p.s.	1760 ft.-lbs.
120 grs.	FFg 1470 f.p.s.	1847 ft.-lbs.

.50 CALIBER ROUND BALL

Lead .490" Dia. Ball -179 grain

Powder Charge	Muzzle Velocity	Muzzle Energy
80 grs.	FFg 1650 f.p.s.	1082 ft.-lbs.
90 grs.	FFg 1750 f.p.s.	1197 ft.-lbs.
100 grs.	FFg 1840 f.p.s.	1346 ft.-lbs.
110 grs.	FFg 2050 f.p.s.	1670 ft.-lbs.

Loading and Shooting Procedures (cont'd)

To Adjust Sights.

The Remington Genesis™ ML is equipped with a fully adjustable rear sight. It can be adjusted for both windage (left to right) and elevation (up and down).

⚠ WARNING! Never attempt to adjust the sights on a loaded firearm.

TO ADJUST THE REAR SIGHT:

Move the rear sight slide for elevation adjustment. Move the rear sight aperture for windage adjustment. Move the slide or aperture in the same direction as you need the point of impact on the target to move. (See **Picture 18**).

TELESCOPIC SIGHTS:

The top of the barrel has holes for the installation of a telescopic sight base. Scope bases are available for purchase as an accessory item. See your retailer for a Remington Genesis™ ML accessory scope base.

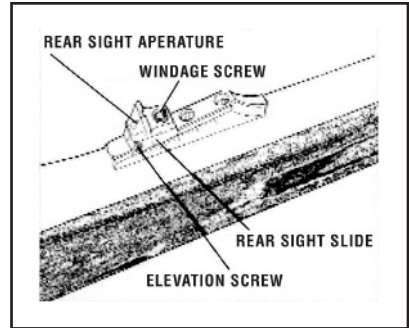

Picture 18

Note: The use of telescopic sights is **illegal** in some areas during the big-game muzzleloading season. Be sure to check the regulations in the area you will be hunting before installing the scope.

Removing a Charge and Projectile (Unloading).

Under normal conditions a muzzleloading firearm is unloaded by simply firing it into a safe and suitable backstop. There are however, three conditions which may occur that will require the rifle to be unloaded manually. These are:

1. A misfire or failure to fire.

⚠ WARNING! FOR A MISFIRE OR FAILURE TO FIRE, WAIT AT LEAST ONE MINUTE WITH THE RIFLE POINTED IN A SAFE DIRECTION. A LINGERING SPARK SMOLDERING IN THE POWDER COULD FIRE THE RIFLE AT ANY MOMENT.

2. Powder fouling or other circumstances causing the projectile to become lodged partially down the barrel after firing.
3. The projectile is not firmly seated against the powder charge and cannot be made to do so with normal ramrod pressure.

If any of these situations arise, the projectile must be removed from the barrel as follows:

1. Keeping the muzzle pointed in a safe direction, put the safety mechanism to the 'Safe' position.
2. Open the Torch Cam™ breech block so that the breech plug is visible. See page 12.
3. If there is a 209 primer in the primer pocket of the breech plug, remove it and check to insure that there is no remaining primer residue in the primer pocket or flash hole.
4. Remove the ramrod from beneath the barrel.
5. Turn the rifle upside down so that the trigger guard is up and the muzzle is pointed in a safe direction.

Loading and Shooting Procedures (cont'd)

Removing a Charge and Projectile (Unloading).

6. Remove the two rear take down screws, (See **Picture 19**) and remove the barrel and fore end assembly from the receiver. (See **Picture 20**).
7. Remove the fore end attachment screw (See **Picture 19**), and remove the fore end from the barrel. (See **Picture 21**).

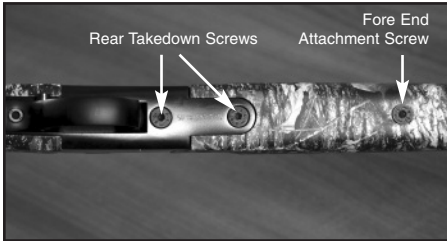

Picture 19

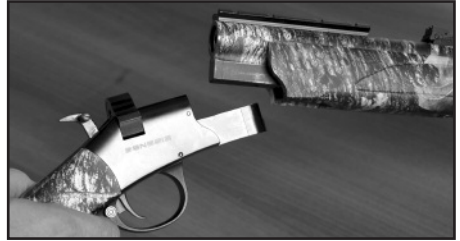

Picture 20

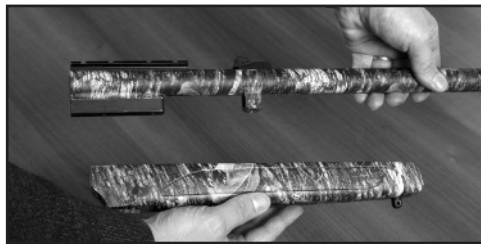

Picture 21

8. Submerge the barrel in a pail of CLEAN water, (hot water is recommended), with the muzzle pointed up, also fill the bore with water so that it is level with the muzzle. Let stand for a minimum of 30 minutes. Be sure that the breech section of the action is submerged to a depth of at least 12 inches so that water can saturate the powder charge through the breech plug. Wait no less than 30 minutes. The powder charge will then be deactivated.

Note: THE POWDER MUST REMAIN SATURATED TO BE DEACTIVATED. SATURATED POWDER WILL NOT IGNITE. IF THERE HAS BEEN A DELAY AFTER STEP 8 AND YOU ARE UNSURE IF THE POWDER IS STILL SATURATED, REPEAT STEP 8.

9. Remove the barrel from the water and pour the water from the bore.
10. Remove the breech plug and proceed to step 11. If the breech plug cannot be removed, attach a screw type bullet puller to the ramrod or cleaning rod. Keep the ramrod or cleaning rod directed away from your face and body while attempting to remove the projectile. Insert the ramrod with the attached bullet puller into the muzzle and twist the bullet puller into the bullet.

NOTE: Considerable force may be necessary to fully engage the bullet puller into the bullet.

Carefully pull the projectile out of the muzzle and wash the remaining saturated powder from the barrel. Omit Step 11 and go directly to step 12.

11. Keep the ramrod or cleaning rod directed away from your face and body while removing the projectile and charge. Insert the ramrod or cleaning rod, with cleaning jag attached, from the muzzle and push the projectile, along with any remaining saturated powder, through the breech end of the barrel. If the projectile and charge cannot be moved rearward, wash away the saturated powder from behind the projectile. Again, keeping the ramrod directed away from your face and body, insert the ramrod or cleaning rod through the breech end of the barrel and gently push the projectile through the barrel and out the muzzle.

Loading and Shooting Procedures (cont'd)

Removing a Charge and Projectile (Unloading).

12. Clean and lubricate the rifle as explained in the cleaning instructions beginning below.

 **WARNING: AN IMPROPERLY CLEANED AND LUBRICATED RIFLE MAY BE DANGEROUS AND COULD RESULT IN AN ACCIDENTAL DISCHARGE AND SERIOUS INJURY OR DEATH TO THE SHOOTER OR BYSTANDERS.**

13. Reassemble the firearm.

Cleaning Instructions

Muzzle Loading Propellants are very corrosive. Failure to clean and lubricate your firearm will damage it and impair its function. Your firearm should receive a thorough cleaning and lubrication each time that it is shot or it is to be stored for more than a week.

 **WARNING: BE SURE THAT YOUR RIFLE IS UNLOADED PRIOR TO CLEANING. SEE PAGE 7. ATTEMPTING TO CLEAN A LOADED OR PRIMED FIREARM CAN CAUSE INJURY OR DEATH TO THE SHOOTER OR BYSTANDERS.**

See pages 21 and 22 to unload the firearm.

Periodic cleaning of the bore may be required during prolonged shooting sessions. The bore should be cleaned if the projectile becomes difficult to load and seat over the powder or if accuracy begins to degrade.

See the procedure for **FIELD CLEANING** on page 28 for cleaning between shots.

Use only Remington 40-X™ Bore Cleaner or Remington Express® Clean Solvent to clean your bore. Use only Remington Rem™ Oil to lubricate your trigger assembly, hammer mechanism and Rem™ Oil or Remington Express® Lube to treat and preserve the bore prior to storage.

Prior to loading and shooting your firearm, it is necessary to thoroughly clean the bore to remove any residual oils that may cause the powder to foul and reduce accuracy.

Using Remington 40-X™ Bore Cleaner or Remington Express® Clean Solvent and cotton patches, repeat steps 1-2 in the "Loading the Powder" Section on page 17, until the patches are visibly clean **before you ever shoot your rifle**. In order to achieve desired accuracy it is necessary to "season" or break-in the barrel. This is accomplished by the initial cleaning, followed by shooting approximately ten (10) consecutive rounds (preferably lead balls or conicals) and repeating the cleaning steps 1-2 in the "Loading the Powder" Section on page 17 and again shooting ten (10) consecutive rounds and then cleaning again.

Thorough Cleaning

TO REMOVE AND CLEAN THE BARREL AND BREECH PLUG:

1. Keeping the muzzle pointed in a safe direction, put the safety mechanism to the 'Safe' position, open the Torch Cam™ breech block and inspect to be sure there is no primer residue remaining in the primer pocket.
2. Use the ramrod to be sure there is no charge in the barrel. See instructions on page 7.

 **WARNING: If there is a charge in the barrel, do not attempt to remove it by shooting it out if you are unsure what the charge is or if you are unsure if the charge is safe. Instead, remove the charge using the instructions on pages 21 and 22.**

Thorough Cleaning (cont'd)

TO REMOVE AND CLEAN THE BARREL AND BREECH PLUG:

3. Remove the ramrod from beneath the barrel.
4. Turn the rifle upside down so that the trigger guard is up and the muzzle is pointed in a safe direction.
5. Remove the two rear take down screws (See Picture 19), and remove the barrel and fore end assembly from the receiver. See Picture 20.
6. Remove the fore end attachment screw, (see Picture 19), and remove the fore end from the barrel. See Picture 21.
7. Remove the breech plug. See page 13.
8. Soak the breech plug in Remington Express® Clean Parts Bath or Remington Express® Clean Concentrate.
9. Using a small brush and Remington Express® Clean Concentrate, clean the breech plug threads in the rear of the barrel thoroughly. Use a cleaning patch or clean cloth to wipe the breech plug threads clean of all residue.
10. Attach the cleaning jag to the ramrod or cleaning rod. Place a cleaning patch soaked with Remington 40-X™ Bore Cleaner or a Remington Express® Clean Patch evenly over the cleaning jag.
11. Insert the jag into the bore and push it firmly into the barrel from the breech. Swab the bore with short strokes for best results. Push the patch through the barrel and remove the cleaning patch at the muzzle.
12. Using the same method, push a dry patch through the bore.
13. Repeat steps 9-11 until the dry patch is clean.
14. Place a cleaning patch soaked with Rem™ Oil or a Remington Express® Lube patch evenly over the jag and push it into the bore from the breech. Swab the bore with short strokes to uniformly coat the bore.
15. Repeat step 13 several times to properly condition and preserve the bore.
16. Thoroughly clean and dry the breech plug.
17. Sparingly apply Remington breech plug grease on the threads of the breech plug.

Note: Avoid putting grease or any other lubricants on the front face of the breech plug and in the flash hole of the primer pocket. Excess grease or lubricants may foul the powder charge and possibly cause a misfire or hang fire.

18. Reinstall the breech plug. See pages 13 and 14.
19. Wipe the exterior of the barrel and receiver with a cloth treated with Rem™ Oil.

TO REASSEMBLE THE BARREL AND FORE END:

1. Place the fore end on the barrel, aligning the hole in the fore end with the hole in the fore end lug on the barrel.
2. Secure the fore end to the barrel by replacing the fore end take down screw. See picture 19.
3. Position the barrel and fore end assembly in the receiver by inserting the breech end of the assembly into the opening at the top of the receiver assembly. (See **Picture 22**).
4. Secure the barrel and fore end assembly to the receiver by replacing the two rear take down screws, see Picture 19.
5. Tighten the rear takedown screws snugly by hand



Picture 22

Thorough Cleaning (cont'd)

TO REMOVE AND CLEAN THE TRIGGER ASSEMBLY:

Use the ramrod to be sure there is no charge in the barrel. See instructions on page 7.

⚠ WARNING: If there is a charge in the barrel, do not attempt to remove it by shooting it out if you are unsure what the charge is or if you are unsure if the charge is safe. Instead, remove the charge using the instructions on pages 21 and 22.

1. Insure that the Safety Mechanism is in the 'SAFE' position
2. Unscrew and remove the hammer spur if installed.
3. With the trigger guard facing up, remove the screw located at the rear of the trigger guard, (See **Picture 23**).
4. Remove the trigger assembly from the receiver by rotating the trigger assembly forward and downward, away from the bottom of the receiver. (See **Picture 24**).



Picture 23



Picture 24

5. Spray the trigger assembly with Remington Rem™ Action Cleaner to remove any residue and debris from the trigger assembly. Shake the trigger assembly to remove any remaining Rem™ Action Cleaner from the trigger assembly and allow to dry thoroughly.
6. Lightly lubricate the trigger assembly with Rem™ Oil at the points shown in (See **Picture 25**) taking care to remove any excess Rem™ Oil from the trigger assembly.
7. With the hammer in the rear or cocked position, cycle the safety mechanism to insure it moves freely from the 'Safe' to 'Fire' position and back to 'Safe'.
8. Check to insure the hammer mechanism and trigger mechanism are operating properly before reinstalling the trigger assembly into the rifle.

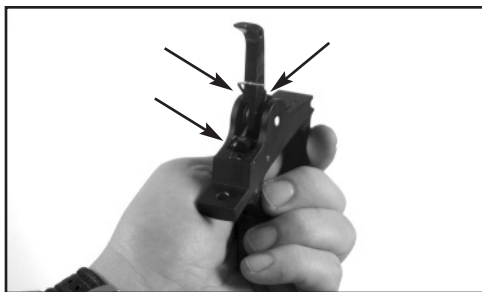

Picture 25

Thorough Cleaning (cont'd)

TO REINSTALL THE TRIGGER ASSEMBLY:

Use the ramrod to be sure there is no charge in the barrel. See instructions on page 7.

⚠ WARNING: If there is a charge in the barrel, do not attempt to remove it by shooting it out if you are unsure what the charge is or if you are unsure if the charge is safe. Instead, remove the charge using the instructions on pages 21 and 22.

1. Insure the hammer is in the down or uncocked position.
2. Insert the trigger assembly into the opening in the bottom of the receiver taking care to insert the hammer through the hammer slot. (See **Picture 24**).
3. Slide the trigger assembly forward, seating the slot in the front of the trigger assembly around the trigger assembly retaining pin located at the front of the opening. (See **Picture 26**).
4. Reinstall the screw located at the rear of the trigger guard and tighten snugly by hand.
5. Reinstall hammer spur.
6. After first checking to make sure that there is no charge in the barrel and no primer in the primer pocket, check to insure that the safety mechanism moves freely from 'Safe' to 'Fire' and back to 'Safe'.

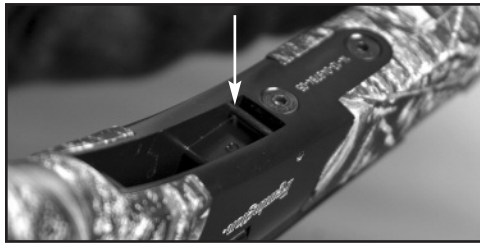

Picture 26

TO DISASSEMBLE AND CLEAN THE TORCH CAM™ BREECH BLOCK AND FIRING PIN ASSEMBLY:

Use the ramrod to be sure there is no charge in the barrel. See instructions on page 7.

1. Insure that the Safety Mechanism is in the 'SAFE' position.
2. Insure that the hammer is in the down or uncocked position.
3. Open the Torch Cam™ breech block.
4. Grasp the Torch Cam™ breech block from the top, placing your thumb over the rear of the firing pin, gripping firmly. (See **Picture 27**).
5. While maintaining the grip referenced above, remove the breech block screw located on the bottom of the Torch Cam™ Breech block. (See **Picture 28**).



Picture 27



Picture 28

NOTE: It is important to hold the firing pin in place while removing the retaining screw as the firing pin assembly is under spring tension from the firing pin spring. Failure to hold the assembly in place while removing the firing pin retaining screw may result in lost parts.

Thorough Cleaning (cont'd)

TO DISASSEMBLE AND CLEAN THE TORCH CAM™ BREECH BLOCK AND FIRING PIN ASSEMBLY: (cont'd)

6. With the breech block screw removed, carefully release pressure from the firing pin assembly and remove the firing pin retainer, firing pin, and firing pin spring from the Torch Cam™ breech block. (See **Picture 29**).

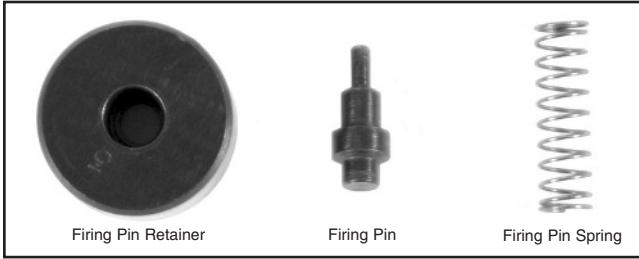

Picture 29

7. Spray the firing pin retainer, firing pin, and firing pin spring and the inside of the Torch Cam™ breech block with Rem™ Action Cleaner to remove any debris or build up from the components. Dry thoroughly before reassembling.
8. Spray the face of the Torch Cam™ breech block with Rem™ Action Cleaner and wipe clean with a soft cloth. Insure that all components are dry prior to reinstalling.
9. Lightly lubricate the firing pin and firing pin spring with Rem™ Oil.
10. Spray the Torch Cam™ detent ball with Rem™ Action Cleaner. (See **Picture 30**).
11. With a small punch or screwdriver, gently depress and release the Torch Cam™ detent ball to insure it moves forward and returns freely. (See **Picture 31**).



Picture 30



Picture 31

TO RESASSEMBLE THE TORCH CAM™ BREECH BLOCK AND FIRING PIN ASSEMBLY:

1. Place the firing pin back into the firing pin retainer as shown in (See **Picture 32**).
2. Place the firing pin spring on top of the firing pin/firing pin collar as shown in (See **Picture 33**).



Picture 32



Picture 33

Thorough Cleaning (cont'd)

TO RESASSEMBLE THE TORCH CAM™ BREECH BLOCK AND FIRING PIN ASSEMBLY:

3. Carefully insert the assembly into the rear of the Torch Cam™ breech block, making sure that the breech block screw holes in the bottom of the breech block and the firing pin retainer are aligned. (See **Picture 34**).
4. Reinstall the breech block screw and tighten snugly by hand.
5. With a small punch or screwdriver, gently press the rear of the firing pin to insure that it moves forward and then returns in the Torch Cam™ breech block. (See **Picture 35**).

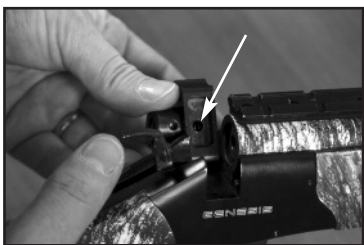

Picture 34



Picture 35

Field Cleaning

⚠ WARNING: BE SURE THAT YOUR RIFLE IS UNLOADED PRIOR TO CLEANING. SEE PAGE 7. ATTEMPTING TO CLEAN A LOADED OR PRIMED FIREARM CAN CAUSE INJURY OR DEATH TO THE SHOOTER OR BYSTANDERS.

See pages 21 and 22 to unload the firearm.

Follow this procedure to clean your muzzleloader in the field:

1. Keeping the muzzle pointed in a safe direction, put the safety mechanism in the 'Safe' position, open the Torch Cam™ breech block and be sure there is no primer or primer residue remaining in the primer pocket of the breech plug.
2. Use the ramrod to ensure there is no charge in the barrel. See page 7.

⚠ WARNING: If there is a charge in the barrel, do not attempt to remove it by shooting it out if you are unsure what the charge is or if you are unsure if the charge is safe. Instead, remove the charge using the instructions on pages 21 and 22.

3. Attach the cleaning jag to the ramrod with a ramrod extension attached or to a cleaning rod for use with rifled bores. Place a cleaning patch soaked with Remington 40-X™ Bore Cleaner or a Remington Express® Clean patch evenly over cleaning jag.
4. Push the cleaning jag into the barrel at the muzzle and swab the bore with short strokes until the jag reaches the breech plug. Remove the ramrod and remove the cleaning patch from the jag.
5. Repeat step 4 with a dry patch.
6. Repeat steps 3-5 until the dry patch remains clean.
7. Place a cleaning patch saturated with Rem™ Oil or a Remington Express® Lube patch evenly over the jag and push it into the bore from the breech. Swab the bore with short strokes to uniformly apply the Rem™ Oil or Remington Express® Lube to the internal surfaces of the barrel.
8. Repeat step 7 several times to properly condition and preserve the bore.

Field Cleaning (cont'd)

9. Point the firearm in a safe direction and fire at least two 209 primers to make sure the flash hole is clear. Residual bore cleaner or lubricants at the breech could saturate the powder and increase the possibility of a misfire or hang fire.
10. Clean the face of the Torch Cam™ breech block by wiping it clean with a soft cloth or patch saturated with Rem™ Oil or Express® Clean solvent.

⚠ WARNING: Wait at least one full minute after firing the last percussion cap before pouring powder into the bore to allow time for any residual sparks to be extinguished:

PARTS AND SERVICE

To Order Parts

ALL PARTS ARE SUBJECT TO A \$10.00 CHARGE FOR SHIPPING AND HANDLING. Some parts are restricted and may only be installed by returning the rifle to us. When ordering parts, please state the Model, Serial Number, and Finish Color. For parts information, call (860) 388-4656.

Service

To obtain information about returning your rifle for service or repairs, call (860) 388-4656.

One Year Limited Warranty

This rifle is warranted to the original retail customer for one year from the date of retail purchase against defects in material and workmanship. All parts and labor or replacement at our option are covered. The wood stock is not covered by the one year warranty. The warranty on the wood stock is 60 days and is limited to the original retail customer and extends 60 days from the date of retail purchase and covers only manufactured and material defects.

Transportation to and from our repair facilities, government fees, damage caused by failure to perform normal maintenance, sales outside the United States, damage caused by use of high velocity, high pressure, reloaded or other nonstandard ammunition, or by any unauthorized repair, modification, misuse, abuse or alteration of the rifle is not covered by this Limited Warranty.

Implied Warranty

ANY IMPLIED WARRANTIES, INCLUDING THE IMPLIED WARRANTIES OF MERCHANT ABILITY AND FITNESS FOR A PARTICULAR PURPOSE, ARE LIMITED IN DURATION TO ONE YEAR FROM THE DATE OF ORIGINAL RETAIL PURCHASE. SOME STATES DO NOT ALLOW LIMITATIONS ON HOW LONG AN IMPLIED WARRANTY LASTS, SO THE ABOVE LIMITATION MAY NOT APPLY TO YOU.

To the extent any provision of this warranty is prohibited by federal, state, or municipal law, which cannot be pre-empted, it shall not be applicable. This warranty gives you specific legal rights, and you may also have other rights which may vary from state to state.

To obtain warranty service, send your shotgun with proof of retail purchase, freight prepaid to:

REMINGTON I.S.P.

c/o TSG

1375 Boston Post Road

Old Saybrook, CT 06475

NOTICE: It is illegal to ship a firearm with ammunition in the firearm or in the same packaging. Firearms and ammunition must be shipped separately. For information about shipping ammunition, call (860) 388-4556.

Remington Genesis™ Exploded View and Parts List

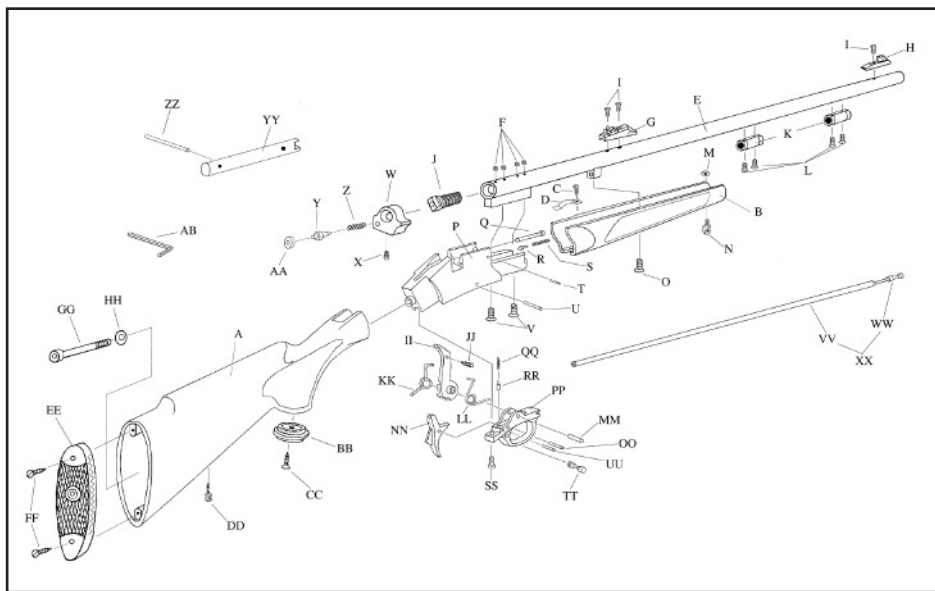

Reference	Description	Reference	Description
A	Rear Stock (AW Composite) (Finished)	Z	Firing Pin Spring
B	Fore Stock (AW Composite) (Finished)	AA	Firing Pin Retainer
C	Ramrod Retaining Spring Screw.	BB	Pistol Grip Cap
D	Ramrod Retaining Spring	CC	Pistol grip Cap Screw
E	Barrel Assembly (Kit) (Length 28") .50 cal. perc. (twist 1-28")	DD	Sling Swivel Stud-Rear
	Barrel Assembly (Finished) (Length 28") .50 cal. perc. Blued (twist 1-28")	EE	Buttpad
F	Plug Screw (4)	FF	Buttpad Screw (2)
G	Rear Sight	GG	Tang Screw
H	Front Sight	HH	Tang Screw Washer
I	Rear and Front Sights Screw (3)	II	Hammer
J	Breech Plug (inox)	JJ	Hammer Handle
K	Ramrod Thimble (2)	KK	Hammer Mainspring
L	Ramrod Thimble Screw (4)	LL	Hammer Antagonist Spring
M	Sling Swivel Stud – Front nut	MM	Hammer Pin
N	Sling Swivel Stud – Front	NN	Trigger
O	Forend Stock Screw	OO	Trigger Pin
P	Frame (Aluminum)(Blued)	PP	Trigger Guard
Q	Breech Block Pin	QQ	Trigger Guard Spring
R	Clic – Breech Block	RR	Pin
S	Clic - Breech Block Spring	SS	Trigger Guard Screw
T	Clic Pin	TT	Safety
U	Trigger Guard Pin	UU	Safety Pin
V	Frame-Barrel Screw (2)	VV	Ramrod 28" (Aluminum)
W	Breech Block	WW	Ramrod Tip .50 Cal (Aluminum)
X	Breech Block Screw	XX	Ramrod Assembly
Y	Firing Pin	YY	Wrench
		ZZ	Wrench Handle
		AB	Allen Wrenc

Remington®

Remington is a trademark registered in the United States Patent and Trademark Office by Remington Arms Company, Inc.