

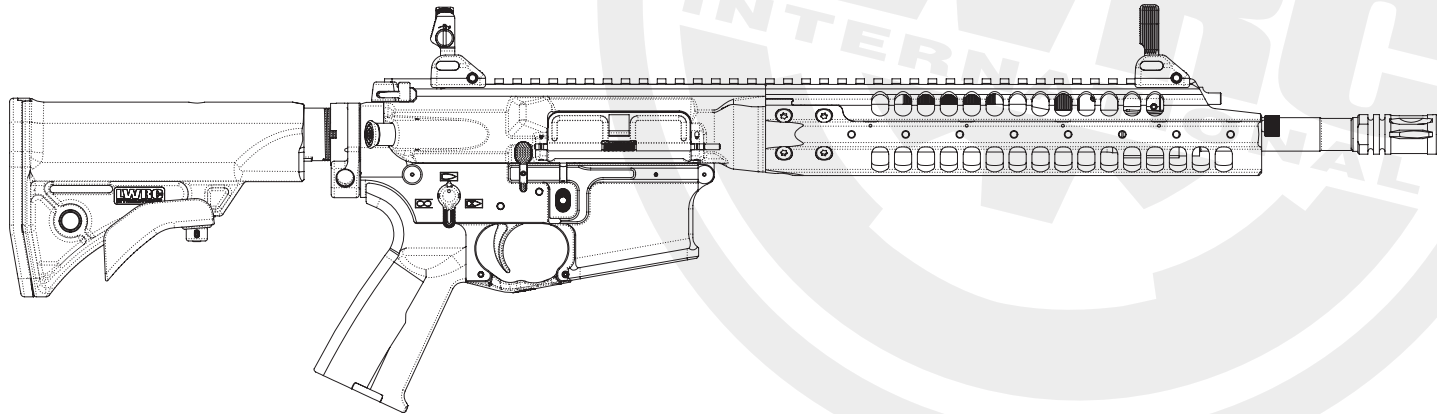

INDIVIDUAL CARBINE

OPERATOR'S MANUAL

IC-ENHANCED | IC-A2 | IC-A5 | IC-SPR | IC-PDW | IC-PSD | IC-PSD PISTOL



LWRCI™ | HIGH-PERFORMANCE FIREARMS | LWRCI.COM



TABLE OF CONTENTS

1.0 Weapon Safety	5	5.0 Maintenance	26
1.1 General Safety Procedures	6	5.1 Lubricants & Cleaners	26
1.2 Weapon Conditions	7	5.2 Field Stripping	27
		5.3 Detailed Disassembly	30
2.0 Individual Carbine Series Overview	8	5.4 Reassembly	32
2.1 Technical Data	8	5.5 Routine Maintenance	33
2.2 Weapon Nomenclature	10	5.6 Detailed Maintenance	33
2.3 Operating Controls	15	5.7 Maintenance Procedures for Adverse Climates	34
3.0 Pre-Operating Procedures	19	5.8 SPR Rail Configuration and Maintenance	34
3.1 Clearing Your Weapon	19		
3.2 Pre-Fire Inspection	19	6.0 Troubleshooting	35
3.3 Pre-Fire Function Test	21	6.1 Suppressor Use	35
4.0 Operation	22	6.2 Weapon Failure Descriptions and Solutions	36
4.1 Choice of Ammunition	22		
4.2 Choice of Magazines	22		
4.3 Initial Loading of the Weapon	22		
4.4 Firing in Semi-Automatic Mode	23		
4.5 Firing in Automatic Mode	23		
4.6 Reloading from Bolt Lock	23		
4.7 Operating Cycle	24		



DIRECTLY DESCENDED FROM THE RIFLES DEVELOPED BY LWRCI™ TO MEET THE REQUIREMENTS OF THE U.S. ARMY INDIVIDUAL CARBINE PROGRAM, THE IC SERIES OF RIFLES IS ENGINEERED FOR OPTIMAL PERFORMANCE. THE LWRCI™ IC RIFLE IS A ROTARY BOLT, MAGAZINE-FED, AIR-COOLED, SELF-LOADING FIREARM CHAMBERED IN 5.56X45MM THAT IS BUILT AROUND THE PATENTED LWRCI SHORT STROKE GAS-PISTON SYSTEM. BASED OFF OF THE FAMILIAR AR-15 ARCHITECTURE, THE IC IS AVAILABLE IN A WIDE VARIETY OF CONFIGURATIONS TO MEET ANY NEED OR REQUIREMENT.



1.0 WEAPON SAFETY

Congratulations on your purchase of an LWRCI™ IC Series High-Performance Firearm. Our rifles are designed and manufactured with the highest quality components for optimal performance for operators and shooters. Ownership and operation of this firearm takes a high level of personal responsibility. Completely read and thoroughly understand this manual prior to operating your Individual Carbine.

CAUTION: THIS IC IS A FIREARM. WHEN HANDLED CARELESSLY OR IMPROPERLY, NEGLIGENT DISCHARGES CAN OCCUR, CAUSING INJURY, DEATH, OR DAMAGE TO PROPERTY.

NOTICE: LWRC International, LLC shall not be responsible for injury, death, or damage from either intentional or negligent discharge of this firearm or from its function when used in a manner other than designed.

IMPORTANT: Careless or improper handling, unauthorized adjustment or parts replacement, neglect, poor storage and the use of wrong caliber or any ammunition other than recommended will prejudice any warranties extended by LWRC International on this Firearm.



LWRCI.COM | 410.901.1348 5

1.1 GENERAL SAFETY PROCEDURES

When handling any type of firearm, the shooter must, at all times, keep in mind the cardinal safety rules of weapons handling:

THE FOUR FIREARMS SAFETY RULES

1. Treat every weapon as if it were loaded at all times.
2. Never point your weapon at anything that you do not intend to destroy.
3. Keep your finger off of the trigger until you intend to fire.
4. Keep the weapon's safety on until you intend to fire.



An important part of safe handling, especially around other people, is to frequently ensure that the weapon is clear when it is not being actively shot. For example, when handing your weapon to another person, clear the weapon and lock the bolt carrier to the rear using the bolt catch. When the receiving person takes the weapon, the new holder should follow the clearing procedure (including visual inspection of the chamber). Please consult section 3 of this manual for instructions on how to clear your IC.

Always ensure that you are firing the correct caliber ammunition through your weapon. To ensure proper function and safety, LWRCI recommends using factory-loaded ammunition that complies with SAAMI, NATO, or CIP published standards. LWRCI does not guarantee your weapon's safety or performance when using reloaded, hand loaded, or surplus ammunition.

Every LWRCI weapon is shipped with a chamber safety flag. It is recommended that the bolt NOT be slammed on the safety flag to increase the life of your flag.

Check your weapon's bore to ensure that it is free from any obstructions before loading and firing the weapon, especially for the initial firing after a period of inactivity (storage, cleaning, etc.). In the event that the weapon is dropped or the muzzle touches the ground, clear the weapon before checking for a bore obstruction.

Prior to firing, know your intended target and what lies beyond it. Be sure that there is an adequate backstop or open space free of persons and other unintended targets. Keep in mind that hard objects behind your target can cause ricochets, posing a safety hazard to property, persons in the vicinity, and the shooter.

Be aware of where your muzzle points at all times and, regardless of the status of the weapon, never point the weapon's muzzle at any person or unintended target. When not being carried by a shooter, the weapon should be placed in a 'Range Safe' condition: the magazine is removed, the muzzle faces downrange, the ejection port is open and faces up, the bolt carrier is locked to the rear, and the selector is set to SAFE.

Weapons should be stored unloaded, either in a locked case or in a secure area, such as an armory. Always remember to return the chamber safety flag to the empty chamber to give yourself and others around a visual indicator that your weapon is in a safe condition.

Always use eye and ear protection when shooting any firearm.

Familiarize yourself with the weapon, its controls, features and operating procedures prior to shooting.

1.2 WEAPON CONDITIONS

Throughout this manual and in some training courses, various "conditions" are used to describe how the IC's controls and components are oriented. These conditions allow for common starting points in describing how to manipulate the weapon. The conditions for the IC (and other AR-style weapons) are an extension of the commonly taught Handgun Readiness Conditions, and the condition descriptions are as follows:

CONDITION 4: Bolt forward on an empty chamber, no magazine inserted, hammer down, and selector on FIRE. (The selector is not able to turn to SAFE).

CONDITION 3: Bolt forward on an empty chamber, magazine inserted, hammer down, and selector on FIRE. (The selector is not able to turn to SAFE).

CONDITION 2: Not applicable for the IC.

CONDITION 1: Bolt forward with round chambered, magazine inserted, hammer cocked, and selector on SAFE.

CONDITION 0: Bolt forward with a round chambered, magazine inserted, hammer cocked, and selector on FIRE.

In addition to these traditional conditions, the 'Range Safe' condition was described earlier as: bolt locked to rear, ejection port cover open, no magazine inserted, and selector on SAFE.



CALIBER
5.56mm NATO

MUZZLE THREADS
½ x 28 TPI

RIFLING
1/7" RH

MAGAZINE CAPACITY
10/30

TRIGGER PULL
5.5-8.5 lbs.

CYCLIC RATE
750-900

SUSTAINABLE RATE OF FIRE
70 RPM

2.0 INDIVIDUAL CARBINE SERIES OVERVIEW

Directly descended from the rifles developed by LWRCI to meet the requirements of the U.S. Army Individual Carbine Program, the IC Line is built for performance. Designed with revolutionary new features IC delivers best-in-class-design, ergonomics and flawless functionality.

2.1 TECHNICAL DATA

	IC-SPR 16.1"	IC-SPR 14.7"	IC-PSD 10.5"	IC-PDW 8.5"
OVERALL LENGTH	31.9" - 34.5"	30.5" - 33.1"	27.3" - 29.9"	20.5" - 25.5"
WEIGHT	7.1 lbs	7.0 lbs	6.5 lbs	5.9 lbs
MAX EFFECTIVE RANGE	500 yards	500 yards	300 yards	300 yards

BARREL:

6-groove rifling, 1-in-7 RH twist, 41v45 CMV Steel, NiCorr-coated, cold hammer-forged, including Rifling and Chamber, M4 Barrel Extension with Extended Feed Ramps, Nickel-Boron Coated

3-PIECE PISTON OPERATING SYSTEM:

Gas System length changes with barrel length

MONOFORGE UPPER RECEIVER:

Type III Anodize or Cerakote

FULLY AMBIDEXTROUS LOWER RECEIVER:

Type III Anodize or Cerakote

MODULAR RAIL SYSTEM:

Type III Anodize or Cerakote
Rail length changes with barrel length and varies from 7" to 12" depending on model

LWRCI AMBI CHARGING HANDLE

BOLT CARRIER:

One-Piece, Anti-Tilt, Nickel-Boron Coated

MIL-SPEC BUFFER TUBE, H2 BUFFER, MIL-SPEC BUFFER SPRING

LWRCI COMPACT STOCK



IC-SPR



IC-PSD



IC-ENHANCED



IC-PSD PISTOL



IC-A2



IC-PDW



IC-A5

2.2 WEAPON NOMENCLATURE

This section identifies the primary parts and features of the IC Series.

2.2.1 IC-SPR | IC-PSD



LEFT SIDE VIEW

- | | | |
|------------------------------|-----------------------------|-------------------------------|
| 1. Flash Hider | 6. Monoforge Upper Receiver | 11. Ambi Selector |
| 2. Skirmish BUIS Front Sight | 7. Skirmish BUIS Rear Sight | 12. Ambi Mag Release |
| 3. LWRCI Barrel | 8. Ambi Charging Handle | 13. Trigger |
| 4. LWRCI Piston System | 9. LWRCI Compact Stock | 14. Ambi Bolt Catch & Release |
| 5. Modular Rail | 10. Rear Take-Down Pin | 15. Magazine |

RIGHT SIDE VIEW



16. Front Take-Down Pin
(Pivot Pin)

17. Forward Assist

18. Brass Deflector

19. Ejection Port Cover

20. Bolt Carrier (Inside)

21. LWRCI Sling Plate

22. Magpul MOE+ Grip

23. LWRCI Enhanced Trigger Guard

24. Ambi Mag Release

25. One-Piece Gas Block

26. Pusher Screw

2.2.2 IC-A5 | IC-ENHANCED
27. 2-Position Gas Regulator



2.2.3 IC-A2
28. Quad Rails
29. LWRCI Rail Skins





2.2.4 IC-PDW

- 30. LWRCI Rail Panels
- 31. PDW Carrier (Inside)
- 32. PDW Stock/Buffer Tube
- 33. MOE-K Grip
- 34. LWRCI Hand Stop



2.2.5 IC-PSD PISTOL

- 35. PSD Pistol Buffer System

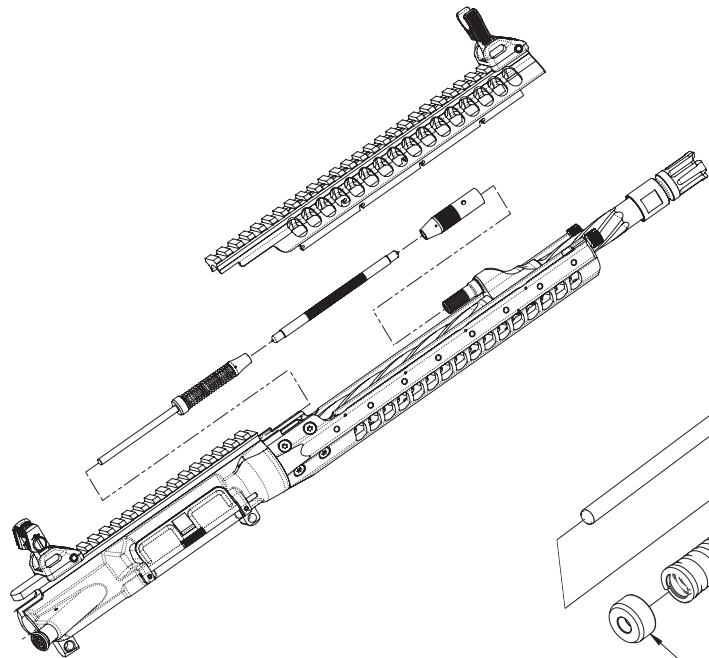

Fig. 2A IC-SPR Disassembled

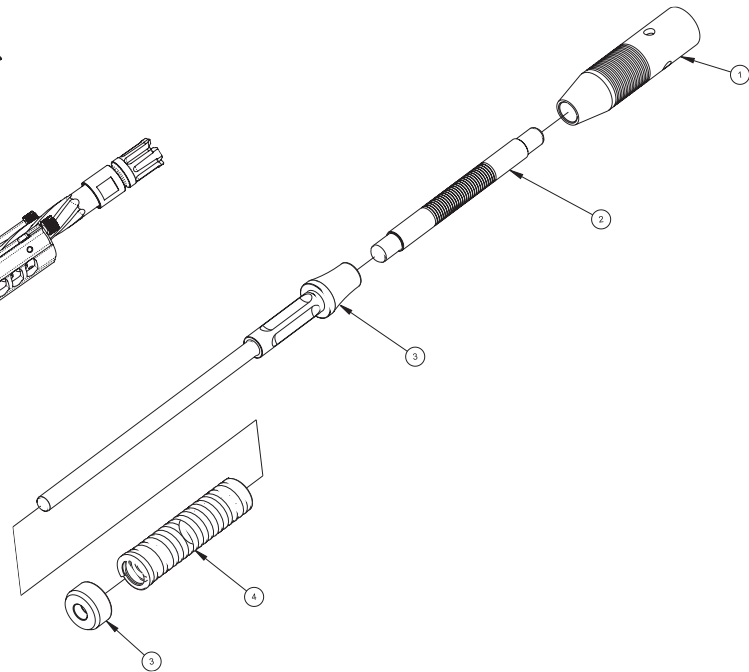

Fig. 2B IC Piston Disassembled

- 1. Piston Cup
- 2. Intermediate Rod
- 3. Operating Rod
- 4. Piston Spring
- 5. Piston Spring Cup

2.3 OPERATING CONTROLS

This section details the function of the parts of the weapon that the shooter will manipulate during firing.

2.3.1 AMBI SELECTOR (ITEM 11)

Located on both sides of the IC rifle, the Ambidextrous Selector functions as both the manual safety and the fire mode selector. The receiver is marked with pictograms for all three modes:



SAFE

Prevents the trigger from releasing the hammer.



SEMI-AUTOMATIC

Allows for one shot per pull of the trigger.



AUTOMATIC

Allows for continuous firing for as long as the trigger is pulled.

All LWRCI rifles are marked with the AUTOMATIC pictogram, but the AUTOMATIC setting is only functional in a select-fire weapon. The AUTOMATIC setting cannot be engaged in a semi-automatic weapon.

Note that the selector can only be set to SAFE when the hammer is cocked.

2.3.2 TRIGGER (13)

The trigger is used to fire the weapon. The area in which the trigger is located is called the trigger well. The trigger well is enclosed on the bottom by the trigger guard (item 23). The IC comes equipped with the LWRCI Enhanced Fire Control Group (EFCG), a single stage trigger with pull weight of 5.5-8.5 lbs. Geissele fire control groups are available as factory upgrades. The Geissele fire control group can improve the crispness and reduce the pull weight to as low as 2.8 lbs..

CAUTION: Although numerous aftermarket fire control groups are available, LWRCI can only warranty the use of the fire control group supplied with your weapon.

CAUTION: Installation of aftermarket accessories that extend into the trigger guard area of the weapon are discouraged. They could result in a negligent discharge and void of warranty.

2.3.3 AMBI CHARGING HANDLE (8)

The IC is equipped with an LWRCI Ambi Charging Handle. Pulling on the latches of the charging handle will unlock the charging handle and allow the user to draw the bolt carrier group to the rear. The carrier group is drawn to the rear in order to either lock the carrier group back using the bolt catch or (more commonly) to charge the rifle with a new round from the magazine.

When charging the rifle, always use a sharp tug directly backwards to avoid binding, and allow the charging handle to travel back to its home position with the momentum of the carrier. Holding on to the charging handle as it moves forward will impede the consistent feeding process, resulting in stoppages. The only time you should "ride" the carrier home is when you are placing the chamber flag in the bore. Riding the carrier home will prevent damage or breaking the chamber flag.

The contemporary method of charging the rifle is to use the support side hand to manipulate the charging handle while the strong hand retains control of the grip and firearm.

2.3.4 AMBI BOLT CATCH AND RELEASE (14)

The IC has controls for the bolt catch and release on either side of the lower receiver.

To lock the bolt carrier back, use the charging handle to pull the bolt carrier group back until the leading face of the bolt passes the bolt catch. Once the bolt face has cleared the bolt catch, press the lower section of either of the bolt catch paddles. The carrier should now be locked back and the charging handle can be returned to the home position manually.

To release the bolt carrier group from its locked back position, press the top half of either bolt catch paddle. The carrier will be released and return to its home position.

2.3.5 AMBI MAGAZINE RELEASE (12) (24)

Magazines that are properly inserted into the IC's magazine well will automatically be caught and locked in place. Usually an audible click can be heard when the magazine is fully seated, but tugging on the magazine will verify that it is locked in place.

The magazine is released by depressing the magazine releases located on either side of the lower. On the left side of the receiver, the magazine release is in the form of a paddle; the right side release is the more traditional button. Magazines may or may not drop free. A tug on the magazine while depressing the mag release will ensure removal.

CAUTION: Remember that removing the magazine does not mean that the weapon is unloaded; there may still be a round in the chamber. The chamber can be checked by clearing the weapon (several pulls of the charging handle is standard) before visually inspecting the chamber. Devices such as chamber flags can be used to further ensure that the chamber is clear in a low-visibility scenario.

2.3.6 FORWARD ASSIST (17)

The forward assist is used to ensure that a cartridge is fully seated into the chamber. Repeatedly tapping on the forward assist button forces a not-fully-seated carrier to move forward in small increments. One or two firm taps with the palm of the hand is recommended if deemed necessary, but excessive force should not be required to fully seat a new round. DO NOT force a round into the chamber. If several firm taps do not fully seat the round, follow the clearing procedure and inspect the round, the magazine, the chamber, and the bore of the weapon. The forward assist is more commonly used in situations where regular cleaning is not possible, or when debris is introduced into the action of the rifle (desert conditions, dropped weapon, etc.). Normal "range" firing will very, very rarely require the use of the forward assist.

2.3.7 EJECTION PORT COVER (19)

The spring-loaded ejection port cover is used to keep debris and foreign matter from entering the upper receiver through the ejection port. It opens automatically when the weapon is cycled, either by hand

or by firing. The ejection port cover should always be closed when the weapon is no longer firing with the exception of the 'Range Safe' condition. To close it, simply push the cover up until it engages the upper receiver.

2.3.8 LWRCI COMPACT STOCK (9) IC PDW STOCK (32)

The standard IC comes equipped with an LWRCI Compact Stock fitted to a 6-position buffer tube. The Ultra Compact Stock and corresponding buffer tube are fitted to some shorter models; this stock system has 5 adjustment positions and is approximately 1" shorter than the Compact Stock when both stocks are fully extended. To adjust the length of pull of either stock, hold down the back of the stock release lever and slide the stock forwards or backwards to the desired position. Release the lever and rock the stock forward and back until you hear a click, ensuring that the stock is locked in place.

The shortest model of the IC, the IC-PDW, comes equipped with the LWRCI PDW Stock. When fully extended, the PDW stock is approximately 1" shorter than the Ultra Compact Stock and, therefore, 2" shorter than the Compact Stock. The PDW Stock has either a closed or an open position. From the closed position, the stock may be extended without pressing the release button. Once the stock is fully extended and locked into place, however, the release button must be pressed in order to collapse the stock again.

2.3.9 2-POSITION GAS REGULATOR (27)

The IC-E and IC-A5 variants possess a 2-position gas regulator at the front of the rail. The two settings of the regulator are for Normal fire and for Suppressed fire. For Normal mode, the tab at the end of the gas block should be horizontal. For Suppressed mode, the tab should be rotated to vertical. The "S UP" lettering should be straight up and down when the gas block is in Suppressed mode. The cap can usually be rotated by hand, but a tool (such as the tip of a bullet) can be used to rotate knob when it becomes hot or if fouling causes the cap to stick.



Fig. 2.3.9A shows the regulator in Normal.



Fig. 2.3.9B shows the regulator set to Suppressed



2.3.10 SKIRMISH FOLDING SIGHTS (2) (7)

The LWRCI Skirmish sights are MIL-STD-1913/Picatinny mount flip-up sights designed for use on LWRCI and all other standard-AR-height upper receivers. They will work correctly in conjunction with other sights designed for this height, such as the 'F' marked front sight base on a standard M4 carbine. Do not combine Skirmish sights with sight models based on a different height. LWRCI recommends that Skirmish sights be used as a pair whenever possible.

Skirmish sights are not locked in place when folded down. Grasp the sight tower and flip up to deploy either the front or rear sight.

Once it is deployed, the sight towers are locked in the UP position by a detent. To fold the sights back down, depress the button on the left side of the sight, then fold the sight tower down.

Both sights may need to be initially adjusted. Elevation changes to point of impact are made using the front sight post. The front sight post may be moved up or down by turning the post with the sight tool provided with the IC. Use the tool to depress the detent, and then rotate the post to adjust it up or down. The sight post is rotated clockwise to raise the point of impact and counter-clockwise to lower it. Each 'click' of the sight post corresponds to approximately 1.54MOA (1.54" @ 100 yards) on 14.7" and 16.1" IC's; shorter rifles have larger sight radii due to the shorter rails, and the adjustment clicks will have a greater MOA shift on these models.

Windage adjustments to the point of impact are made using the rear sight post. Grasp the two 'heads' on either side of the rear sight post; turning the heads will move the sight post from side-to-side. Each click will move the point of impact approximately 0.62MOA.

The rear sight turret has two aperture settings. To change the aperture, twist the top half of the rear sight post until the desired aperture clicks into position. For a 14.7" IC, the large aperture is suitable for distances of 25-300 yards, while the small aperture has a built-in elevation shift that allows the sight to be used from 300-500 yards.



3.0 PRE-OPERATING PROCEDURES

Several measures should be taken before firing your IC. These pre-operating procedures can be taken as often as the shooter wishes, but they should at the least be completed before every firing session to ensure proper function of the firearm.

3.1 CLEARING THE WEAPON

Clearing your weapon is an important starting and stopping point for many weapon operations. Clear the weapon upon receiving it from someone, when you pass it along to someone, and when it is being set down on the range or for storage. Clearing is also the easiest way to put the weapon into conditions 3-4.

The process for clearing your rifle is as follows:

1. While pointing the muzzle in a safe direction, remove the magazine (if present) by depressing the magazine release and pulling the magazine out.
2. Press and hold the bottom half of either bolt catch lever. The traditionally taught method is to turn the rifle onto its side and hold the bolt catch with the support hand, but the ambi controls of the IC allow for the firing hand to hold open the bolt catch as well.
3. Using the hand that is not holding the bolt catch lever, grasp the charging handle, depress the latch(es) and firmly pull the charging handle and carrier group all the way to the rear. If a round was

chambered, it should have been ejected as the bolt carrier moved to the rear. As it moves all the way to the rear, the bolt carrier group will become trapped by the bolt catch and will not be able to return to the home position. Note that if the carrier group is not pulled completely to the rear, the bolt catch can catch on the front face of the carrier instead of the bolt.

4. Return the charging handle to the closed and latched position.
5. Roll the weapon counter-clockwise until you have a clear view of the bolt and chamber through the ejection port. Visually check to make sure that the chamber is clear and that the bolt is locked to the rear. In low light conditions, perform a tactile check.

CAUTION: Step 5 is a crucial part of the clearing process. Do not depend on the fact that no casing was ejected on clearing. There could still be a live round in the chamber for any number of reasons. Make certain that you inspect the chamber to make sure that it is clear.

3.2 PRE-FIRE INSPECTION (PFI)

A pre-fire inspection should be performed before each firing session.

1. Clear the weapon before placing it into Condition 4.
2. Break the weapon down 'shotgun style' by pulling out the rear takedown pin and pivoting the upper and lower receivers apart.

3. Inspect the bolt carrier group. Remove the bolt carrier group by pulling the charging handle back halfway and sliding the bolt carrier group free of the upper receiver. Check to make sure that the bolt is fully captive in the carrier. Make sure that the cam pin is captive and that it rides in its track smoothly when the bolt is moved in or out. Check for damage on the bolt face and the bolt lugs. Ensure that the firing pin retainer is fully seated in its hole. Ensure that the firing pin hole in the bolt face is not obstructed. Tap the bottom of the bolt carrier firmly against the palm of your hand to ensure that the firing pin is fully captured. A light coating of lubricant is recommended for the body of the carrier and/or the inside of the upper receiver; ensure that the lubricant has not dissipated.
4. Visually inspect the bore for obstructions. In low light conditions, physically inspect the bore by passing a cleaning rod through it. Do not check for bore obstructions using a flexible barrel cleaner. Flexible cleaners, especially worn or used ones, can snag on small obstructions and break, leading to even larger obstructions.
5. Reassemble the weapon by inserting the bolt carrier group into the upper receiver, close up the upper and lower receivers, and re-insert the rear takedown pin. .
6. If applicable, ensure that the adjustment of the gas block is in the appropriate position for the current firing schedule.
7. Inspect your magazines. Ensure that they are clean and not dented or cracked. Pay special attention to the shape of the feed lips on metal magazines. Check that the magazine follower moves freely within the magazine body and returns home under its own spring tension. Do not oil or otherwise lubricate magazines.
8. Inspect the ammunition. Ensure that the ammunition is the correct caliber for the weapon and is not damaged. Do not oil or otherwise lubricate ammunition.

Once the inspection is completed, clear the weapon and return it to either Condition 4 or make it 'Range Safe'.

3.3 PRE-FIRE FUNCTION TEST

The shooter should complete a pre-fire function test of the action and fire control group after the weapon has been disassembled and reassembled. As the pre-fire inspection involves partially breaking the weapon down, a function test should always follow an inspection. Perform the following steps, watching closely for anything that impedes the movement of the carrier group or makes the weapon hard to cycle.

1. Clear the weapon before placing it into Condition 4.
2. Check the function of the magazine catch. Insert an empty magazine into the magazine well, tugging on it to ensure that it is fully seated and held in place by the magazine catch.
3. Check the function of the charging handle and the bolt catch. Grasp the charging handle and pull it to the rear. The bolt carrier group should lock to the rear because of the empty magazine. The charging handle should not return forward on its own accord. Push the charging handle until it is latched back into its home position.
4. Check the function of the magazine release. Release the magazine using the magazine release and remove it from the weapon. The carrier group should remain locked to the rear.
5. Check the bolt release. Press the large paddle on the upper portion of either bolt release. The carrier group should slam forward and lock into battery. Never slam the carrier group forward on your chamber flag. This may cause the flag to break and become stuck in your bore.
6. Check the function of the safety. With the selector on SAFE, pull the trigger. Nothing should happen; the hammer should not drop.
7. Check semi-auto function. Rotate the selector to "SEMI" and pull the trigger. The hammer should drop with a loud click. Repeat this test by charging the weapon (pull the charging handle firmly to the rear, then release).and pulling the trigger again. The hammer should drop.
8. Check the trigger reset. Hold down the trigger while charging the weapon again. Once the charging handle and carrier group have returned home, slowly release the trigger. Listen for a click as you release the trigger; that 'click' is the sound of the disconnecter separating from the hammer. The hammer should remain cocked when the trigger is fully released.
9. Check full-auto function (if applicable). Set the selector to "AUTO". Pull and hold the trigger. The hammer should fall. Charge the weapon at least three times while holding the trigger down. The hammer should fall each time the carrier group goes into the home position.

Once the function test is completed, clear the weapon and return it to either Condition 4 or make it 'Range Safe'.

4.0 OPERATING THE IC

Your IC Series carbine is engineered to perform right out of the box. Each rifle is quality checked and test fired to meet exact tolerances for high performance. This section outlines manufacturer recommendations required to ensure safe and optimal performance.

4.1 CHOICE OF AMMUNITION

To reiterate: always ensure that you are firing the correct caliber ammunition through your weapon. To ensure proper function and safety, LWRCI recommends using factory-loaded ammunition that complies with SAAMI, NATO, or CIP published standards. LWRCI does not guarantee your weapon's safety or performance when using reloaded, hand loaded, or surplus ammunition.

LWRCI does not recommend the use of steel-cased ammunition.

5.56/.223 bullets of less than 50gr should also be avoided.

Subsonic ammunition will not reliably cycle the IC, even when fired with a suppressor.

The IC is designed to cycle with a broad spectrum of 5.56x45mm NATO and .223 Rem ammunition. The 1:7 twist rate of the rifling (one revolution of the rifling takes place every 7") will generally give the best accuracy results with heavier bullets, such as 69-77gr Match offerings. Factory accuracy testing is done with a variety of ammunition, but most

rifles will shoot very well with MK262 77gr OTM. Function testing at the factory is completed using Federal XM193, but M855 and other similar rounds will also function reliably.

4.2 CHOICE OF MAGAZINES

The IC is designed to use AR-15/M-16 pattern magazines. LWRCI recommends the supplied Magpul PMag for use in its rifles. Magazines from other manufacturers can be used, but they should be thoroughly tested for function before operational use.

4.3 INITIAL LOADING OF THE WEAPON

1. Clear the weapon before placing it into Condition 4.
2. Insert a loaded magazine firmly into the magazine well. Ensure that it is properly seated by tugging on it.
3. Charge the weapon by firmly pulling the charging handle to the rear and releasing it. The bolt carrier group will slam forward, picking up the top round in the magazine and putting that round into the chamber.
4. Rotate the selector to SAFE. If you do not intend on firing immediately, close the ejection port cover. The weapon is now in Condition 1.

4.4 FIRING IN SEMI-AUTOMATIC MODE

Starting with the weapon in Condition 1:

- 1 – Bring the weapon to the “Ready” position.
- 2 – Acquire and aim at the intended target.
3. Move the selector to “SEMI”. The weapon is now in Condition 0.
4. Squeeze the trigger with strong, smooth pull to fire individual shots.
5. When you are finished firing, move the selector to SAFE to return the weapon the Condition 1.

If you have fired all of the rounds in the magazine, turn the weapon counter-clockwise and visually inspect the chamber to make sure that it is empty and the bolt carrier is locked back.

4.5 FIRING IN AUTOMATIC MODE

Starting with the Weapon in Condition 1:

1. Bring the weapon to the “Ready” position.
2. Acquire and aim at the intended target.
3. Move the selector to AUTO. The weapon is now in Condition 0.
4. Squeeze and hold the trigger to fire multiple rounds. The weapon will fire until the trigger is released or the magazine runs out of rounds, but 3-5 round bursts are the recommended firing schedule.
5. When you are finished firing, move the selector to SAFE to return the weapon the Condition 1.

If you have fired all of the rounds in the magazine, turn the weapon counter-clockwise and visually inspect the chamber to make sure that it is empty and the bolt carrier is locked back.

4.6 RELOADING FROM BOLT LOCK

When the magazine is out of ammunition, the bolt catch is automatically engaged and the bolt carrier group is locked open.

1. Release and remove the magazine by pressing either of the mag releases.
2. Insert a loaded magazine into the magazine well. Ensure that the magazine is properly seated by tugging on it.
3. Press the large paddle of ether bolt catch, releasing the bolt carrier and chambering a round from the new magazine.

The weapon is now in Condition 1 if the selector was set to SAFE or Condition 0 if the selector was set to SEMI or AUTO.

4.7 OPERATING CYCLE

This section clearly describes the operating cycle of the IC series so that you better understand the unique features and functions of the patented LWRCI short stroke gas piston system. For more information on go to lwrci.com to view a video on the system.



24 LWRCI.COM | 410.901.1348

Firing

When the trigger is pulled, the sear surface between the bottom of the hammer and the front of the trigger is separated. This separation allows the hammer, which is driven by the hammer spring, to “drop” and strike the rear end of the firing pin. The head of the firing pin is driven through the bolt face and strikes the cartridge primer. The powder in the cartridge ignites, and the gas generated by the burning powder forces the projectile from the cartridge and down the barrel.

Unlocking

As the bullet travels down the barrel, its propellant gasses are siphoned off by the gas port. These gasses travel through the gas block and into the nozzle where they pressurize the piston cup. That pressure forces the piston cup, intermediate rod, and operating rod away from the nozzle. The end of the operating rod contacts the tombstone on the bolt carrier, and the bolt carrier group is forced back into the upper receiver. The rearward motion of the carrier group is called the recoil stroke. As the carrier group moves to the rear, the cam pin follows the path of the cam track in the upper receiver, causing the bolt to rotate until the lugs of the bolt are no longer in line with the lugs of the barrel extension.

Extraction

As the bolt carrier group continues its recoil stroke, the extractor (the part of the bolt that grips the rim of the cartridge case) holds firmly to the cartridge, causing the empty cartridge to be withdrawn, or extracted, from the chamber.

Ejection

Once the empty cartridge is withdrawn to the ejection port, it is flung from the weapon by the spring loaded ejector, located on the bolt face.

Cocking

In semi-automatic firing, as the bolt carrier recoils to the rear, it cocks the hammer. The hammer is initially retained by the disconnecter. As the shooter lets go of the trigger, the disconnecter releases the hammer. The hammer moves slightly before re-engaging the front face of the trigger. This re-engagement is called the reset.

In automatic firing, as the bolt carrier recoils to the rear, it cocks the hammer on the auto sear. As the carrier moves back forward after it has completed its recoil stroke, the rear of the carrier will trip the auto sear, releasing the hammer and firing the round. When the shooter releases the trigger, the hammer is caught by the hammer/trigger engagement surface and the fire control group is reset.

Feeding

The recoil stroke concludes when the buffer halts the rearward motions of the bolt carrier group. The buffer spring, which was compressed during the recoil stroke, drives the bolt carrier group forward. This forward motion is called the counter-recoil or return stroke. As the bolt carrier moves forward, the next round is stripped from the top of the magazine and directed into the chamber by the magazine feed lips and the receiver feed ramps.

Chambering

As the bolt carrier group continues the return stroke, the round is seated in the chamber.

Locking

The bolt carrier group completes the forward motion of the return stroke, the bolt locking lugs pass between the barrel extension lugs. During the last ½" of bolt carrier group travel, the cam pin moves from the guide channel into the cam pin recess, rotating the bolt counter-clockwise and locking the bolt lugs against the barrel extension lugs.



5.0 MAINTENANCE

Proper maintenance of a weapon requires not only post-fire cleaning but also the timely replacement of worn parts to ensure full reliability and performance. An accurate log of rounds fired is ideal, but a rough daily round count is immensely useful for scheduled maintenance.

5.1 LUBRICANTS AND CLEANERS

The IC is compatible with all standard U.S. Military and NATO specified small arms lubricants and cleaners. For lubricants, LWRCI uses Slip 2000 EWL and Carbon Killer in the factory, but numerous CLP-style lubricants and cleaners have been successfully tested by IC operators all over the world.

Note that the use of water-based lubricants, such as WD-40, is not advised as the water content of the lubricant can actually aid corrosion.

When applying lubricant, use a moderate coat of lubricant on moving parts. A moderate coat should be just visible to the eye. Apply lubricant directly to the part and spread it with a brush, cloth, or finger.

Zones to lubricate include:

1. Bolt carrier body and cam pin, especially along the runners on the bottom of the carrier and the bosses on the rear. Place two drops of lubrication into cam pin slot.
2. Inside of the upper receiver
3. Outside of the long, thin section of the charging handle
4. Takedown pins

NOTE: Do not lubricate the piston system. These parts are designed to run dry.

5.2 FIELD STRIP

Field Stripping, or Basic Disassembly, is breaking the rifle down to its core components for the purpose of field-expedient maintenance (mainly cleaning and lubrication). Field Stripping can also shed light on the cause of common failures, such as a blocked bore or broken parts. The Field Stripping process requires no special tools. Caution should be taken to ensure that parts are not lost during this process.

Please note that rifles should not be broken down beyond the field strip unless in a controlled environment, such as the factory or in a gunsmith's shop.

To start the field strip, separate the upper and lower receiver groups:

1. Clear the rifle several times. Most negligent discharges occur during disassembly and cleaning operations.
2. From the left-hand side, press in the rear takedown pin. From the right-hand side, pull the rear takedown pin to the right until it stops. FIG 5.2.A
3. Repeat step 2 for the front pivot pin. FIG 5.2.B
4. Separate the upper and lower receiver groups. FIG 5.2.C



5.2.A

REAR TAKEDOWN PIN



5.2.B

FRONT TAKEDOWN PIN



5.2.C

SEPARATED UPPER
AND LOWER RECEIVER
GROUPS



To complete the field strip of the lower receiver assembly, remove the buffer and spring from the buffer tube:

1. With the hammer cocked, depress the buffer retainer using a screwdriver, punch, or other suitable tool. The buffer should spring free. FIG 5.2.D
2. Pull on the buffer to remove the buffer and buffer spring from the lower receiver. FIG 5.2.E



To complete the field strip of the upper receiver assembly, remove the bolt carrier group and charging handle from the upper:

1. Pull the charging handle to the rear about three-quarters of the way.
2. Remove the bolt carrier group from the upper receiver. FIG 5.2.F
3. Pull the charging handle fully towards the rear. Remove the charging handle by moving it downward so the expanded end of the charging handle passes through the cut-out in the guide track of the upper receiver.



5.2.G IC-E DISASSEMBLED

- A. UPPER RECEIVER
- B. BOLT CARRIER GROUP
- C. CHARGING HANDLE
- D. LOWER RECEIVER
- E. BUFFER SPRING
- F. BUFFER



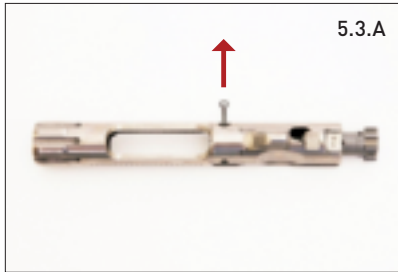

5.3.A

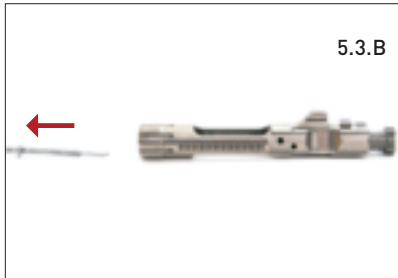

5.3.B

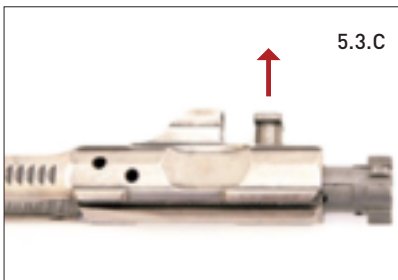

5.3.C

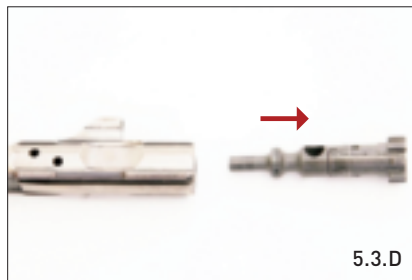

5.3.D

5.3 DETAILED DISASSEMBLY

Detailed disassembly is simply breaking down the rifle as much as is possible without specialized tools. This type of disassembly should be done routinely. For example, the detailed disassembly might be done after several thousand rounds of suppressed fire or before the rifle is put away for extended storage.

To complete the detailed disassembly of the lower receiver, simply remove the stock:

1. Grasp the adjustment lever on the underside of the buttstock. Pull the adjustment lever straight down to disengage the stock pin, and then slide the stock off of the end of the buffer tube.

To fully disassemble the bolt carrier group:

1. Cup the bolt carrier group in one hand and, with a suitable punch or the tip of a cartridge, push out the firing pin retainer in to your cupped hand. Do not twist the retainer during removal. FIG 5.3.A
2. Slide the firing pin out of the rear of the carrier. FIG 5.3.B
3. Lift the cam pin out of the bolt carrier group. FIG 5.3.C
4. Remove the bolt from the front of the bolt carrier. FIG 5.3 D

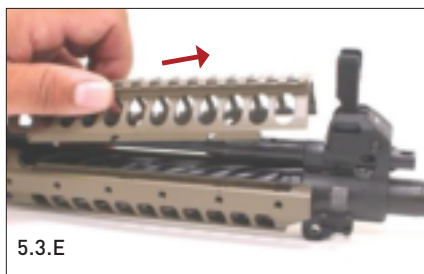

5.3.E



5.3.F



5.3.G

Finally, to finish the detailed disassembly of the upper receiver assembly, remove the piston system:

1. Loosen the pusher screws at the front of the rail. The screws are captive and will remain in the rail; do not remove them completely. FIG 5.3.E
2. Slide the top rail forward to disengage it from the titanium pins in the lower rail. FIG 5.3.E
3. Lift the upper rail to separate it from the lower rail. FIG 5.3.E
4. Ensure that the piston cup stays fully forward during the rest of the process, either by angling the upper receiver assembly downward or by keeping the piston cup in place with a hand.
5. Grab the operating rod near where the operating rod mates with the intermediate rod and pull back, compressing the spring on the operating rod. The intermediate rod will separate from the piston cup. FIG 5.3.F
6. Maintain the compression of the spring and pull the intermediate rod free of the assembly. FIG 5.3.G
7. Remove the piston cup from the nozzle on the gas block. FIG 5.3.H
8. Relax the compression of the operating rod and remove it from the upper receiver. FIG 5.3.I



5.3.H



5.3.I

5.4 REASSEMBLY

Reassembly of the IC is achieved by reversing the order of the disassembly steps. Some items to keep in mind during the reassembly are:

1. When reassembling the piston set, insert the operating rod first and compress the spring. Install the piston cup second. Lastly, install the intermediate rod. The first end of the intermediate rod should be inserted into the operating rod, then the second end should go into the piston cup. Spin all three parts to make sure they are seated correctly; there should not be any binding of the parts.
2. **CAUTION:** Always ensure that the piston components and the top rail are in place and properly installed when reassembling the rifle. The weapon can fire without the intermediate rod or operating rod in place and could result in severe personal injury.
3. When reinstalling the buffer and buffer spring, push the buffer fully into the buffer tube, passing the buffer detent to ensure that it is fully captured by the detent.
4. Do not forget the cam pin. The rifle may chamber a round and fire without the cam pin, but that shot could lead to catastrophic failure of the weapon.
5. Some degree of looseness of fit between the upper and lower receiver may be present. While this is normal and has no effect on the function of the rifle, IC's are equipped with a nylon-tipped tension screw which may be adjusted to address the looseness. The tension screw is located inside the lower's fire control group pocket positioned beneath the upper's rear take-down lug.

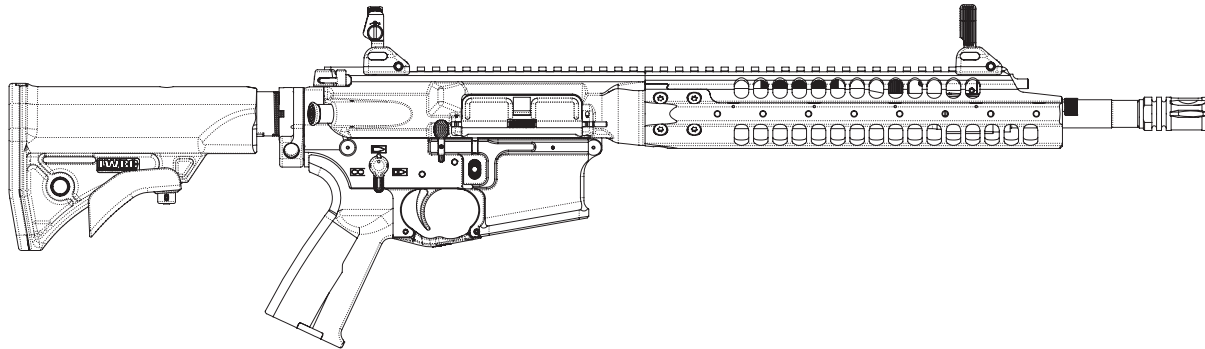

5.5 ROUTINE MAINTENANCE

Routine maintenance is performed after each firing session or once daily while operating in normal field conditions. As always, clear the weapon before performing any maintenance.

1. Clear the weapon
2. Field strip the weapon as detailed in section 5.3.
3. Clean the bore of the barrel. Using a cleaning rod, push a bore patch soaked with solvent from the chamber end of the barrel to the muzzle end. Remove the bore patch and cleaning rod, then let the barrel sit for several minutes.
4. Using a cleaning rod with a bore brush, punch the bore several times to break buildup free.
5. Punch the bore with a dry patch to remove the residue and solvent. Repeat this step until the patches come through the bore clean.
6. Wipe the bolt carrier, charging handle, interior of upper receiver, buffer and buffer spring with a cloth slightly dampened with cleaning solvent if available.
7. Scrub the face of the bolt with a nylon brush dipped in cleaning solvent
8. Remove the solvent from the parts with a cloth or rag.
9. Apply a coat of lube to the interior of the upper receiver, buffer spring, charging handle, and bolt carrier. Do not lubricate the face of the bolt.
10. Apply point lubrication to the cam pin, hammer pin, trigger pin, and charging handle latch.
11. Reassemble the weapon and check to make sure that all moving parts are functioning correctly.

5.6 DETAILED MAINTENANCE

Detailed maintenance should be performed every 2,000 rounds or once weekly while operating in normal field conditions

1. Clear the weapon.
2. Complete the detailed disassembly as described in section 5. 3.
3. Complete all of the routine maintenance detailed in section 5.5.
4. Scrub the bolt (including the extractor) with a nylon brush dipped in solvent. Pay particular attention to removing build up of any type in the extractor groove. Wipe away any remaining solvent with a rag or cloth.
5. Scrub the bolt carrier, firing pin, and the interior of the upper receiver with a nylon brush dipped in cleaning solvent.
6. Clean the firing pin hole and firing pin cavity of the bolt with a pipe cleaner.
7. Wipe away any remaining solvent thoroughly with a rag.
8. Apply a moderate coat of lubricant to the cavity on the carrier into which the bolt is installed.

9. Scrub the piston system components with a dry brass wire brush, including the gas block nozzle, both inside and out. Wipe away any remaining carbon residue with a rag and cleaning solvent. You may have to repeat this process if the nozzle or piston cup has been heavily fouled in a moist environment as carbon is hygroscopic and can form very hard deposits.
10. Fully dry the piston components. No lubrication should be used on these parts.
11. Reassemble the weapon and check to make sure that all moving parts are functioning correctly.

5.7 MAINTENANCE PROCEDURES FOR ADVERSE CLIMATES

In blowing sand and snowy conditions, conduct frequent function checks of your weapon and take every opportunity to remove sand and snow from the weapon. Carrying a small brush is highly recommended. Compressed air can also be used to blow sand from the weapon.

Do not lubricate the interior of the upper receiver or any exterior parts of the rifle when operating in extremely sandy or snowy field conditions. Apply point lubrication as sparingly as possible.

When performing routine maintenance, remove the top rail and brush away any sand or snow from the piston components

For arctic environments:

- Use an arctic rated lubricant
- If the weapon is brought inside from a cold, dry area, allow the weapons to warm to room temperature before performing

maintenance. Pay particular attention to removing condensation before moving back into cold temperatures

- If snow gets inside the weapon, break it down shotgun-style and remove snow from inside the upper receiver and bolt carrier. Check the bore for snow and remove the snow if necessary
- If the rifle freezes shut, do not attempt to un-jam it by firing it. Warm the weapon using body heat or other source of heat until unjammed. If using an open flame, hold the weapon at least eight inches above the flame with the muzzle in a safe direction and with the magazine removed prior to warming until unjammed. Clear or fire the weapon immediately

5.8 SPR RAIL CONFIGURATION AND MAINTENANCE

The IC is equipped with user-configurable rails that allow for the direct attachment of rail segments and other shooting accessories.

To install a rail accessory, use the supplied T20 Torx-head screws that come with the accessory. Match the installation holes to the desired hole position on the rail and tighten until hand tight, or no more than 15 in-lbs. The screws come with a patch of thread locker pre-applied, but if a screw has to be removed and reinstalled, apply a drop of blue Loctite 242 to the screw before reinstallation.

During firing, the section of the rail around the gas block will become fouled with carbon and some copper residue. This fouling occurs because the piston cup vents under the handguards. If left alone, the copper deposits will oxidize into a blue-green color. While this discoloration is purely cosmetic and has no effect on weapon function, it is easily removed with copper solvent.

6.0 TROUBLESHOOTING

The following sections describe the various failures that can occur during operation of the IC. It is important to note that the cause of many failures lies with the magazine. The magazine is a disposable part of the weapon system and one that wears out quickly compared to the rest of the IC. It is good practice to mark and number magazines to allow for easy identification of old/worn/defective ones.

6.1 SUPPRESSOR USE

Suppressors can cause a weapon to exhibit overgassed signs. Simply put, suppressors increase the pressure present inside the weapon, leading to an overgassed situation. Without an adjustable gas block, there are limited options to remedy this situation:

- Use lower pressure ammo
- Consult the factory. LWRCI may be able to offer a previously discovered solution depending on the specific model in question. While using a suppressor on a non-adjustable gun does not always cause failure, suppressors will always lead to higher cyclic rates and increased blowback/fouling

6.2 FAILURE TO SEAT

Magazine will not lock into rifle

CAUSE	CORRECTIVE ACTION
Too many rounds in magazine	Remove rounds from magazine and do not exceed magazine capacity when reloading. (Recommended to download duty magazines by two rounds for highest reliability).
Bent/damaged magazine feed lips or locking recess cut out	Inspect magazine and replace as necessary.
Bent/broken magazine catch	Inspect magazine catch assembly and replace as necessary (armorer level repair).

6.3 FAILURE TO LOAD

No round present in chamber after charging, releasing bolt

CAUSE	CORRECTIVE ACTION
Magazine not seated properly	Re-insert magazine, tap/tug to ensure locked in place, charge rifle or release bolt catch.
Rifle not fully charged	Ensure charging handle is pulled all the way to the rear before release.
Unable to fully charge rifle	Ensure correct buffer and spring are installed, check buffer roll pin is flush with outside of buffer body, inspect buffer tube for FOD (Foreign Object Detected).
Bent/damaged magazine feed lips not allowing rounds to sit at proper height to be loaded	Inspect Magazine and replace as necessary.
Worn/damaged bolt lugs causing bolt to skip over rounds	Replace bolt.
Object detected in magazine	Replace magazine spring and/or follower, clean magazine.

6.4 FAILURE TO FEED

Bolt lugs pushing on back of cartridge case, nose of round jammed into receiver ramps, barrel extension feed ramps or lugs.

CAUSE	CORRECTIVE ACTION
Worn out/incorrect Buffer Spring	Replace Buffer Spring. Do not try to stretch.
Too many rounds in magazine	Remove rounds from magazine and do not exceed magazine capacity when reloading. (Recommended to down-load duty magazines by two rounds for highest reliability).
Magazine not seated properly	Re-insert magazine, tap/tug to ensure locked in place, charge rifle or release bolt catch.
Bent/damaged magazine feed lips not allowing round to feed at correct angle	Inspect magazine and replace as necessary.
Worn/weak magazine spring not pushing rounds up to correct height in order to be fed properly	Replace magazine spring.
FOD (Foreign Objects Detected) in magazine	Disassemble and clean magazine.

6.5 FAILURE TO CHAMBER

Round has pushed past feed ramps and failed to enter chamber at correct angle. *Do not attempt to reuse failed round.

CAUSE	CORRECTIVE ACTION
Magazine not seated properly	Remove magazine, lock bolt to rear, clear failed round, reinsert magazine and ensure it is seated properly.
FOD (Foreign Objected Detected) in receiver/barrel extension/chamber.	Clear, field strip rifle, inspect and clean inside receiver/barrel extension/chamber.
Short Stroke	See Short Stroke section for remedies.

6.6 FAILURE TO LOCK

Round has entered chamber correctly but bolt has not fully locked into barrel extension or seated cartridge base properly onto bolt face. *Do not attempt to reuse failed round.

CAUSE	CORRECTIVE ACTION
Wrong ammunition for chamber	Inspect all ammunition prior to use and ensure it is the correct caliber and SAAMI/CIP/NATO compliant.
FOD (Foreign Objected Detected) in receiver/barrel extension/bolt face/under extractor	Clear, field strip rifle, inspect and clean bolt face, under extractor, inside chamber and barrel extension.
Ammunition defective/damaged or out of specification	Inspect all ammunition prior to use and ensure it is the correct caliber and SAAMI/CIP/NATO compliant.
Weak worn buffer spring	Replace buffer spring.

6.7 FAILURE TO FIRE

LIVE round in chamber, trigger is pulled, NO shot is fired.

CAUSE	CORRECTIVE ACTION
Defective ammunition/dead primer	Inspect all ammunition prior to use and ensure it is the correct caliber and SAAMI/CIP/NATO compliant.
Broken/weak hammer spring	Replace hammer spring.
Worn/broken firing pin	Replace firing pin.
FOD (Foreign Object Detected) in receiver/barrel extension/bolt face/under extractor.	Clear, field strip rifle, inspect and clean bolt face, under extractor, inside chamber and barrel extension.
Carrier Bounce/ Bolt Bounce	See Carrier Bounce/ Bolt Bounce section for solutions.
	

6.8 FAILURE TO EXTRACT

Spent case remains in chamber after firing and carrier group has either short stroked and returned forward or fully cycled and attempted to load a new round into a now blocked chamber.

CAUSE	CORRECTIVE ACTION
Worn/broken extractor and/or extractor spring	Replace extractor and/or extractor spring.
Corroded/Out of specification ammunition	Inspect all ammunition prior to use and ensure it is the correct caliber and SAAMI/CIP/NATO compliant.
Torn case rim	Defective ammunition or dirty chamber. Clean chamber and inspect ammunition.
FOD (Foreign Object Detected) in receiver/barrel extension/bolt face/under extractor	Clear, field strip rifle, inspect and clean bolt face, under extractor, inside chamber and barrel extension.
Ammunition defective/damaged or out of specification	Inspect all ammunition prior to use and ensure it is the correct caliber and SAAMI/CIP/NATO compliant.
Weak worn buffer spring	Replace buffer spring.

6.9 FAILURE TO EJECT

Spent case has been pulled partially or completely from the chamber into the receiver but has failed to clear the ejection port. This is commonly confused with a double feed because the following round is usually jammed in with a spent case, resembling two LIVE rounds in the receiver. See Double Feed for more details.

CAUSE	CORRECTIVE ACTION
Worn/broken ejector spring	Replace ejector spring (armorer level repair).
FOD (Foreign Objected Detected) under extractor not allowing spent case to be released	Inspect, remove and clean extractor.
Gas regulator on wrong setting (A5 and Enhanced models)	Adjust regulator to correct setting.
FOD (Foreign Objected Detected) in receiver/barrel extension/bolt face/under extractor	Clear, field strip rifle, inspect and clean bolt face, under extractor, inside chamber and barrel extension.
Bound/broken ejector	Remove ejector, inspect, replace/clean as needed.
Short stroke	See Short Stroke section for solutions.

6.10 CARRIER BOUNCE/BOLT BOUNCE

During full-auto fire, the bolt carrier group rebounds off of the barrel extension when it comes forward into battery. As the firing pin will not protrude through the bolt face unless the bolt carrier group is fully in battery, bolt bounce causes the hammer to strike the firing pin while the pin is still recessed in the bolt, leading to a LIVE ROUND chambered and un-fired even though the trigger is still being pulled.

CAUSE	CORRECTIVE ACTION
Worn/Incorrect buffer spring	Replace buffer spring. Use manufacturer recommended springs only.
Incorrect buffer (too light)	Use manufacturer recommended buffers only.
Worn/broken piston return spring	Replace piston return spring.
Gas regulator on wrong setting (A5 and Enhanced models)	Adjust regulator to correct setting.
Suppressor causing excessive back pressure in operating system and rifle has no regulator	Install heavier buffer and stronger buffer spring.
Over powered ammunition	Inspect all ammunition prior to use and ensure it is the correct caliber and SAAMI/CIP/NATO compliant.

6.11 SHORT STROKE

Insufficient amount of force or excessive drag in the operating system, not allowing the rifle to fully complete its operational cycle.

CAUSE	CORRECTIVE ACTION
Under powered ammunition	Inspect all ammunition prior to use and ensure it is the correct caliber and SAAMI/CIP/NATO compliant.
Dirty, fouled and/or dry operating system	Clean bolt carrier group, inside of upper receiver, chamber and piston system. Apply point lubrication.
Receiver extension misaligned causing drag on carrier group	Re-install and realign receiver extension (armorer-level repair).
Gas block loose or cracked, resulting in a loss of pressure	Re-pin loose block, replace barrel assembly if cracked (armorer-level repair).
Incorrect buffer (too heavy) and/or buffer spring installed in rifle	Use only manufacturer recommended springs and buffers.
Under-powered ammunition	Inspect all ammunition prior to use and ensure it is the correct caliber and SAAMI/CIP/NATO compliant.

6.12 STOVE PIPE

Spent casings are jammed sideways between bolt and ejection port, typically a result of the rifle operating system cycling too fast. *More common with fully automatic models and when equipped with suppressors.

CAUSE	CORRECTIVE ACTION
Broken/worn piston spring	Inspect piston spring and replace as necessary.
Worn/Incorrect buffer spring	Replace buffer spring. Do not try to stretch it back.
Incorrect buffer (too light)	Use manufacturer recommended buffers only.
Gas regulator on wrong setting (A5 and Enhanced models)	Adjust regulator to correct setting.
Suppressor causing excessive back pressure in operating system and rifle has no regulator	Install heavier buffer and stronger buffer spring.
Over powered ammunition	Inspect all ammunition prior to use and ensure it is the correct caliber and SAAMI/CIP/NATO compliant.

6.13 DOUBLE FEED

Two LIVE rounds being simultaneously fed into chamber. This is always a magazine or operator induced failure.

CAUSE	CORRECTIVE ACTION
Bent/damaged feed lips	Inspect magazine and replace as necessary.
	

6.14 ACCURACY ISSUES

Shots failing to group consistently.

CAUSE	CORRECTIVE ACTION
Ammunition defective/damaged/low quality or out of specification	Inspect all ammunition prior to use and ensure it is the correct caliber and SAAMI/CIP/NATO compliant. Use match grade ammunition of good provenance for best results.
Sights/optics/optic mounts not torqued or installed properly	Ensure all Sights/optics/optic mounts are torqued down per manufacturer's specifications.
Bore fouled with carbon and/or copper causing rounds not to stabilize properly	Clean bore with carbon/copper solvent. Follow instructions provided with solvent.
Loose gas block affecting the barrel's vibrational harmonics	Re-pin gas block (armorer-level repair).

6.15 TUMBLING ROUNDS (KEYHOLING)

Rounds are failing to stabilize in bore, striking the target sideways, resembling a "keyhole" shape.

CAUSE	CORRECTIVE ACTION
Ammunition defective/damaged or out of specification	Inspect all ammunition prior to use and ensure it is the correct caliber and SAAMI/CIP/NATO compliant.
Bore fouled with carbon and/or copper causing rounds not to stabilize properly	Clean bore with carbon/copper solvent. Follow instructions provided with solvent.
Barrel has reached the end of its service life	Replace barrel assembly. (armorer-level repair).

NOTE: Barrel life can be significantly shortened by excessive rates of fire which heats the barrel and its NiCorr case surface conversion to a point where the metallurgical properties of the barrel changes.

Excessive heat also causes the bore diameter to expand to a point where it allows the propellant gasses to overtake the bullet travelling up the bore. These compressed high pressure jets can cut and erode the bore.

The use of projectiles that do not readily compress like sintered powdered metal frangible projectiles, solid metal (copper/brass) projectiles and jacketed projectiles with non-lead cores like M855A1 will result in shortened barrel life.

Shorter barrels generally also have a shorter barrel life as there is less barrel to stabilize the projectiles after throat and bore erosion which is concentrated on the chamber end.

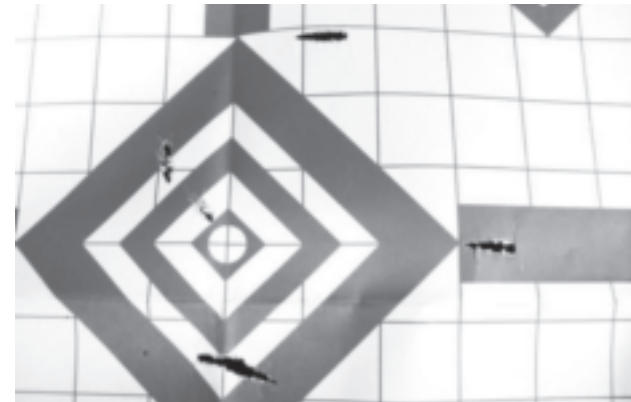



IC SERIES PATENTS PENDING

No parts of this document may be copied, reproduced or transmitted in any form or for any purpose without expressed written consent from LWRC International LLC.

® All rights reserved.
2016 LWRCI.

WARRANTY

LWRCI™ products are warranted to be free from defective materials and workmanship for the life of the original purchaser. LWRCI™'s obligation under this warranty shall be limited to (1) repairing or (2) replacing any product that, upon inspection at LWRCI™ and based on its discretion, is found to be defective in material or in workmanship.

This warranty is limited and does not extend to: careless handling, abuse and misuse, unauthorized adjustments or modifications, use of improper or remanufactured ammunition, excessive or unreasonable use, ordinary wear-and-tear, rust or corrosion, and damages due to non-factory barrel obstructions. Repairs and replacements are warranted for the duration of the original warranty. This warranty applies only to factory built products that have been purchased through an authorized LWRCI distributor or direct dealer. The warranty is only good for the original purchaser of the product.

Exclusive Remedy: The remedies in this section and in the warranty agreement constitute the sole and exclusive remedies of any authorized customer, as well as its successors and assigns, for any defect in the product.

Disclaimer: The warranty stated in this agreement is the sole and exclusive warranty pertaining to the product. LWRCI™ disclaims any warranty, express or implied, including, without limitation, any warranty of merchantability or fitness for a particular purpose. In no event shall LWRCI™ be responsible for any indirect, incidental, or consequential damages including, without limitations, lost profits or costs of delay, with respect to economic loss or injury to property or to third parties, whether as a result of breach of express or implied warranty, negligence or otherwise.

Prior to returning any LWRCI™ product for warranty work, you must receive return material authorization (RMA) from our customer service department. The contact information is available in this document. Items are return shipped using prepaid shipping. LWRCI™, LLC accepts no responsibility for items lost or damaged in shipping. Items that are returned and found to be Out-of-Warranty will be repaired at the customer's expense; however, no work will be performed without the customer's written authorization.



STEP UP TO LWRCI - HIGH-PERFORMANCE FIREARMS



LWRC INTERNATIONAL, LLC | CAMBRIDGE, MARYLAND 21613

410.901.1348 P | 410.228.1775 F | LWRCI.COM

015-0016 Revision A 11.15.15

