

INSTRUCTION MANUAL

CHIAPPA
firearms

1886 and 1892 LEVER ACTION



1892 Lever Action



1886 Lever Action



NASGW



OFFICIAL SPONSOR

ATTENTION: BEFORE REMOVING THIS FIREARM FROM ITS PACKAGE READ & UNDERSTAND WARNINGS, INSTRUCTIONS AND PRECAUTIONS IN THIS USER'S MANUAL

INDEX

WARNINGS.....	3
SAFETY RULES	4
WINCHESTER 1892 SHORT HISTORY	6
WINCHESTER 1886 SHORT HISTORY	6
A NOTE ABOUT HISTORICAL FIREARM DESIGN	6
MODEL RANGE.....	7
IDENTIFYING MARKINGS	8
LEVER ACTION MAIN PARTS NOMENCLATURE	9
LEVER ACTION TAKE DOWN	9
AMMUNITION.....	10
INSTRUCTIONS FOR USE	11
LOADING THE MAGAZINE.....	11
REAR SIGHT ADJUSTMENT	13
FRONT SIGHT ADJUSTMENT	13
TAKE DOWN VERSION	14
MAGAZINE REDUCTION REMOVAL.....	14
SAFETY FEATURES	16
ORDINARY & EXTRAORDINARY MAINTENANCE	16
TROUBLESHOOTING TIPS	17
REAR SIGHT FOR 1892 ALASKAN AND 1886 KODIAK.....	18
EXPLODED VIEW MODEL 1892	19
PARTS LIST MODEL 1892	20
CHART – DIFFERENT COMPONENTS.....	22
EXPLODED VIEW CAL 38-357 EXTRA COMPONENTS	23
EXPLODED VIEW TAKE DOWN EXTRA COMPONENTS	23
EXPLODED VIEW -CARBINE EXTRA COMPONENTS.....	24
EXPLODED VIEW -CARBINE SADDLE RING EXTRA COMPONENTS.....	24
EXPLODED COMPONENTS FOR MAGAZINE AND REAR SIGHT ASSEMBLIES.....	25
EXPLODED VIEW - REAR SIGHT EXTRA COMPONENTS	25
EXPLODED VIEW MODEL 1886	26
PARTS LIST MODEL 1886	27
WARRANTY CONDITIONS	28

WARNINGS

The manufacturer is not responsible for damage to objects caused by misuse of the gun or for injuries to persons or animals, or in case of death, caused voluntarily or involuntarily by the gun user.

The manufacturer is not responsible for injuries caused by poor maintenance, misuse of the gun, unauthorized or improper modifications.

The manufacturer declines responsibility for the indirect consequences of any injuries and / or death of persons or animals, damage to objects caused by use of the gun or by primer explosion, by bullet's ricochet, or unsafe loading practices and / or procedure.

Read the entire manual and learn the proper use of the gun without live ammunition. It is important that you understand the proper use of this product.

The life of the people close to you may depend on your safe behaviour.

If the manual is not clear, please contact the dealer where you bought the gun or call the distributor or the manufacturer by using the contact information provided within this manual.

The manufacturer declines any responsibility for misuse of the firearm. In case of alteration of the firearm, The manufacturer declines any civil and penal responsibility and will not refund any damage.

QUALITY INSPECTION: Every firearm is thoroughly inspected by the manufacturer, for function and cosmetic blemish, prior to shipment.

To guarantee the gun is safe, all guns produced in the Italian facility are sent to the National Proof House of Gardone Val Trompia – BRESCIA – ITALY for proof testing, in compliance with Italian law. The Proof House tests the firearm with heavy loads then checks the barrel, chamber and headspace to make certain the firearm is safe for use with standard factory ammunition. The National Proof House will put their markings on the gun, certifying the gun is qualified and can be sold.

Guns produced in our US facility are scrupulously tested in our premises.

Warning!

Discharging firearms in poorly ventilated areas, cleaning firearms, or handling ammunition may result in exposure to lead or other substances known to the State of California to cause birth defects, reproductive harm, and other serious physical injury. Have adequate ventilation at all times. Wash hands thoroughly after exposure.

ANY LEGAL DISPUTE WILL BE UNDER THE JURISDICTION OF A COURT IN THE STATE OF OHIO – USA, OR IN THE COURT OF BRESCIA – ITALY, AT OUR DISCRETION.

SAFETY RULES

- 1) Read the instructions carefully before use. Reading the manual and careful examination of the gun are fundamental to avoid any kind of problem.
- 2) Be aware that you are handling a firearm; therefore your knowledge and behaviour may affect your life and those of the people close to you.
- 3) Guns and ammunitions must be kept in separate places.
- 4) ALWAYS keep guns and ammunitions out of reach of children.
- 5) Store the gun in a clean, dry and airy place after use to avoid rust in mechanical parts that may cause serious problems in functioning after a period of inactivity.
- 6) The gun must ALWAYS be stored unloaded, ALWAYS check that the chamber is empty.
- 7) Keep away from open flame or heating sources.
- 8) Never leave a loaded gun unattended.
- 9) Never leave the weapon loaded, it could fall and cause injury and death. Always point the gun in a safe direction, and handle it as though it were loaded. This is especially important when loading and unloading the gun, and when handing it to someone else. Never take someone's word that it is unloaded. Always make sure the gun is unloaded before laying it down or handing it to someone else.
- 10) After use, clean and lubricate the inside of the barrel with appropriate oil. Grease or oil build up can cause excessive pressure and result in serious personal injuries. Before using the gun again, inspect the barrel and chamber to make certain that there are no obstructions in the bore. Remove any oil residue with rod and dry patch before shooting.
- 11) Accumulation of rust in the barrel can cause excessive pressures resulting in serious injury and may cause the explosion of the barrel. A rusted, pitted or eroded barrel should be replaced.
- 12) Before shooting ALWAYS check to ensure that the barrel is free of obstructions.
- 13) Never force a jammed action, this act could cause explosion of the round and consequent injury.
- 14) Use exclusively factory loaded ammunition of the caliber specified on the firearm barrel. Use of different calibers may cause serious personal injuries to you and to people close to you.
- 15) In case of misfire, manually extract the cartridge from the chamber. If firearm fails to fire when trigger is pulled, as a result of slow primer ignition (hangfire), keep muzzle pointed downrange for a minimum of 30 seconds. If the round does not fire, remove the magazine, clear the weapon and examine the ejected, unfired cartridge. If the indent from the firing pin is off center, light or absent, take the gun to a competent gunsmith. If the indent appears normal compared to other rounds, assume a faulty round, separate from other cartridges, reload and continue shooting.
- 16) Do not attempt to re-use unexploded ammunitions.
- 17) NEVER modify any parts of your gun. Any alteration may cause serious personal injury and voids the warranty.
- 18) Only a qualified gunsmith may service the gun for repair or serious maintenance.
- 19) Pay great attention during transportation and use. Mechanical safety devices can fail. Developing intelligent, good safety habits is the best way to prevent accidents.
- 20) Never rest your finger on the trigger until the very moment you wish to shoot. Always keep the safety on until you are ready to safely shoot at an intended target (see safety features).
Note: Safety devices on guns are extras and are not a substitute for your proper and safe handling practices.
- 21) ALWAYS keep the gun unloaded when transporting it from home to the shooting areas. Carefully check that cartridge chamber is empty.
- 22) When you walk around with the gun in a shooting area, ALWAYS keep the muzzle pointed in a safe direction.
- 23) NEVER run with a loaded gun, don't cross any obstacle (fences or water courses, etc.) or walk where there is any possibility of slipping or falling without having your firearm unloaded and in safety position.
- 24) When selecting a place to shoot, always be absolutely sure of your target and the area behind it before you touch the trigger, making sure there is an adequate backstop which will stop and contain bullets. A bullet can travel through or past your target with a range up to 1 1/2 miles. If you have any doubt, do not shoot.
- 25) Never shoot against a solid surface or in a pool of water, the projectiles could ricochet and shoot toward any direction. Don't shoot up into the sky.

- 26) Keep all bystanders behind you, standing beside a shooter is not a safe position. Make sure all other shooters and bystanders are well away from the ejection port.
 - 27) Do not smoke while handling, loading or shooting any ammunition, especially black powder. Keep black powder in a closed container at all times, reclosing the container after each and every use.
 - 28) Never drink alcoholic beverages or take any drugs before or during shooting, as this not only constitutes criminal disregard for your safety and that of others, but will seriously impair your judgment and vision. Never use a gun while you are taking medication unless you have checked with your doctor to ensure your fitness to handle the gun safely.
 - 29) Always wear and encourage others near you to wear proper ear protection when shooting, especially on a range since the noise from your gun, and other guns close to you, could result in permanent hearing loss.
 - 30) Always wear protective shooting glasses to protect your eyes from injury by gun powder, gas, lubricant, dirt or metallic particles, carbon residue, sparks or other debris.
 - 31) Wash hands thoroughly after shooting and handling firearms to remove any unwanted residues.
 - 32) NEVER leave the loaded firearm or the loaded magazine in the sun
 - 33) By replica firearms there is no modern safety. In this case you must pay even more attention to safety rules.
- REMEMBER: No mechanical safety device is infallible.

The user is responsible for injuries or damages caused to him or to other persons.

COMPLETE KNOWLEDGE OF YOUR FIREARM CAN MAKE THE DIFFERENCE.

WINCHESTER 1892 SHORT HISTORY

Designed by John M. Browning to replace the Model 1873, the 1892 Winchester rifle became one of the most popular lever actions of all time. It was based on his Model 1886, but reduced in size and chambered for the popular short cartridges used in the Winchester 1873, it was found to be mechanically stronger and cost less to produce than the '73, with a total 1,004,675 manufactured from 1892 through 1941 in both solid and takedown variations. Model 1892 is the epitome of an easy shooting lever and saddle gun. Simplification of the elevator and feeding system gave the 1892 a much smoother action than previous models. This makes 1892 replicas very popular with Cowboy competitors. Armi Sport has developed a rich range of 1892 models for the sport of Cowboy Action Shooting and offers different calibres, barrel lengths and versions.

WINCHESTER 1886 SHORT HISTORY

Model 1886 was developed by John M. Browning on Winchester's request. The factory wanted a rifle for very powerful calibers. Model 1886 is one of the most robust lever action rifles ever produced by Winchester. From 1886 until 1935 about 160.000 pieces were manufactured in the versions rifle, carbine and musket. Model 1886 could chamber the most powerful black powder cartridges of its time: 45-70 Government, .45-90 and .50. At that time price was strongly influenced by the caliber, with the strongest calibers being much more expensive. Armi Sport has developed a range of 1886 Lever Action with two calibers (45/70 and .444Marlin) and two versions (rifle and carbine) for traditional hunting. The carbine version has a 22" barrel and a full-length, 7-shot magazine, while the rifle version with octagonal 26" barrel has an 8-shot magazine capacity.

A NOTE ABOUT HISTORICAL FIREARM DESIGN

Armi Sport proudly manufactures finely crafted firearms product produced to famous historical designs. These firearms are manufactured using precise modern machinery and high quality modern materials. They are faithful reproductions of firearms originally designed in the nineteenth century; however, in choosing to own or use historical firearms the user has to recognize that there have been significant advances in firearms design and safety in the hundred years or more since these firearms were designed. Armi Sport manufactures these guns not as state of the art firearms, but as historically significant firearms for the collector. It is vital that the user be familiar with his firearm and possible safety risks that may be present in the design. Most significantly, the user should realize that the designs of safeties - or even the presence of adequate safeties - vary significantly on historical designs and do not offer the protection against accidental discharge that modern firearms safeties achieve.

Similarly, any firearm that is designed to be fired using black powder (or Pyrodex) has basic risks not found in modern cartridge firearms. Black powder is a dangerous explosive and has to be used and handled with extreme caution. The slightest miscalculation or carelessness with black powder firearms can result in serious injuries to the user. The frame and barrel are not warranted for damage caused by reloaded ammunition.

MODEL RANGE

MODEL	CODE	CALIBER	Barrel length		Total length		Grooves		Weight		Shots
			IN	CM	IN	CM	IN	KG	LBS		
1886 Rifle	920.285	45/70	26"	66	45"	115	6	1 X 18	4,1	9	8+1
1886 Carbine.	920.287	45/70	26"	66	45"	115	6	1 X 18	4,1	9	7+1
1886 KODIAK Trapper	920.301	45/70	18"	46	37"	94	6	1 X 18	3,5	7,8	4+1
1886 KODIAK	920.304	45/70	22"	56	41"	105	6	1 X 18	3,7	8	4+1
1892 Rifle	920.056	4/40Win	20"	50	38"	97	6	1 X 36	3	6,6	10 + 1
1892 Rifle	920.052	4/40Win	24 1/4"	62	42" 1/8	107	6	1 X 36	3	6,6	12 + 1
1892 Rifle	920.063	45 L.C.	20"	50	38"	97	6	1 X 16	3	6,6	10 + 1
1892 Rifle	920.064	45 L.C.	24 1/4"	62	42" 1/8	107	6	1 X 16	3	6,6	12 + 1
1892 Rifle	920.129	357 mag	20"	50	38"	97	6	1 X 19	3	6,6	10 + 1
1892 Rifle	920.131	357 mag	24 1/4"	62	42" 1/8	107	6	1 X 19	3	6,6	12 + 1
1892 Rifle	920.117	38 Spec	20"	50	38"	97	6	1 X 19	3	6,6	10 + 1
1892 Rifle	920.119	38 Spec	24 1/4"	62	42" 1/8	107	6	1 X 19	3	6,6	12 + 1
1892 Rifle	920.153	8/40 win	20"	50	38"	97	6	1 X 36	3	6,6	10 + 1
1892 Rifle	920.155	8/40 win	24 1/4"	62	42" 1/8	107	6	1 X 36	3	6,6	12 + 1
1892 Rifle	920.290	44 Mag	24 1/4"	62	42" 1/8	107	6	1 X 20	3	6,6	12 + 1
1892 Rifle	920.289	44 RM	20"	50	38"	97	6	1 X 20	3	6,6	10 + 1
1892 TRAPPER	920.130	45 LC	16"	40,6	34"	86	6	1 X 16	2,5	5,5	8 + 1
1892 TRAPPER	920.162	57 MAG	16"	40,6	34"	86	6	1 X 19	2,5	5,5	8 + 1
1892 TRAPPER	920.206	44 RM	16"	40,6	34"	86	6	1 X 20	2,5	5,5	8 + 1
1892 Carbine	920.057	4/40Win	20"	50	38"	97	6	1 X 36	3	6,6	10 + 1
1892 Carbine	920.067	45 L.C.	20"	50	38"	97	6	1 X 16	3	6,6	10 + 1
1892 Carbine	920.133	357 mag	20"	50	38"	97	6	1 X 19	3	6,6	10 + 1
1892 Carbine	920.121	38 Spec	20"	50	38"	97	6	1 X 19	3	6,6	10 + 1
1892 Carbine	920.157	8/40 win	20"	50	38"	97	6	1 X 36	3	6,6	10 + 1
1892 Carbine	920.204	44 RM	20"	50	38"	97	6	1 X 20	3	6,6	10 + 1
1892 Rio Bravo	920.100	45 LC	20"	50	38"	97	6	1 X 16	3	6,6	10 + 1
1892 Rio Bravo	920.103	4/40Win	20"	50	38"	97	6	1 X 36	3	6,6	10 + 1
1892 Rio Bravo	920.104	357 mag	20"	50	38"	97	6	1 X 19	3	6,6	10 + 1
1892 Rio Bravo	920.106	38 Spec	20"	50	38"	97	6	1 X 19	3	6,6	10 + 1
1892 Rio Bravo	920.108	8/40 win	20"	50	38"	97	6	1 X 36	3	6,6	10 + 1
1892 Rio Bravo	920.205	44 RM	20"	50	38"	97	6	1 X 20	3	6,6	10 + 1
1892 TAKE DOWN	920.053	4/40Win	24 1/4"	62	42" 1/8	107	6	1 X 36	3	6,6	12 + 1
1892 TAKE DOWN	920.054	4/40Win	20"	50	38"	97	6	1 X 36	3	6,6	10 + 1
1892 TAKE DOWN	920.065	45 L.C.	20"	50	38"	97	6	1 X 16	3	6,6	10 + 1
1892 TAKE DOWN	920.066	45 L.C.	24 1/4"	62	42" 1/8	107	6	1 X 16	3	6,6	12 + 1
1892 TAKE DOWN	920.123	357 Mag	20"	50	38"	97	6	1 X 19	3	6,6	10 + 1
1892 TAKE DOWN	920.125	357 Mag	20"	50	38"	97	6	1 X 19	3	6,6	10 + 1
1892 TAKE DOWN	920.111	38 Spec	20"	50	38"	97	6	1 X 19	3	6,6	10 + 1
1892 TAKE DOWN	920.113	38 Spec	24 1/4"	62	42" 1/8	107	6	1 X 19	3	6,6	12 + 1
1892 TAKE DOWN	920.147	8/40 win	20"	50	38"	97	6	1 X 36	3	6,6	10 + 1
1892 TAKE DOWN	920.149	8/40 win	24 1/4"	62	42" 1/8	107	6	1 X 36	3	6,6	12 + 1
1892 PISTOL	920.185	45 L.C.	12"	30,5	24"	61	6	1 X 16	3	6,6	5 + 1
1892 PISTOL	920.292	4/40Win	12"	30,5	23"	60	6	1 X 36	3	6,6	5 + 1
1892 Pistol Take Down	920.182	45 L.C.	12"	30,5	23"	60	6	1 X 16	3	6,6	5 + 1
1892 Pistol Take Down	920.183	357 Mag	12"	30,5	23"	60	6	1 X 19	3	6,6	5 + 1
1892 Pistol Take Down	920.211	44 RM	12"	30,5	23"	60	6	1 X 20	3	6,6	5 + 1
1892 Alaskan Scout TD	920.311	44 RM	16"	40,6	34"	86	6	1 X 20	2,7	5,5	8 + 1
1892 Alaskan Scout TD	920.312	44 RM	20"	50	38"	97	6	1 X 20	3	6,6	10 + 1
1892 Alaskan Scout TD	920.321	45 L.C.	16"	40,6	34"	86	6	1 X 16	2,7	5,5	8 + 1
1892 Alaskan Scout TD	920.322	45 L.C.	20"	50	38"	97	6	1 X 16	3	6,6	10 + 1

The codes for the above models are the COLOUR CASE version; each version can be supplied with black finish at no surcharge; on request engraving, special engraving, selected or extra stock are available.

IDENTIFYING MARKINGS

Every gun we produce has a serial number that is marked on the receiver/frame. Close to the serial number you will also find the manufacturers information with the model name and caliber marked either on the frame or the slide as required by law.

These markings must not be removed from the firearm for any reason.

Area where serial number is marked under the receiver

The serial number of the gun is visible under the receiver. It must not be removed or modified for any reason.

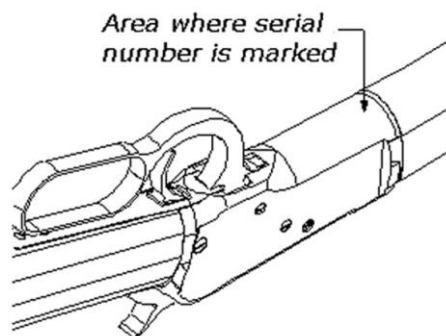

Area marked by National Proof House

Homologation marks of National Proof House are visible under the receiver near the lever.

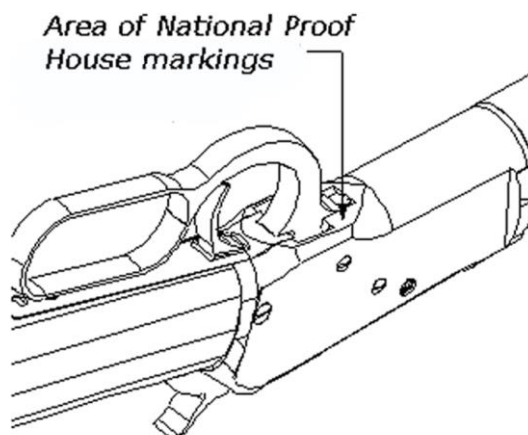

Area of caliber, name of manufacturer and distributor.

Marks of distributor and manufacturer, caliber are visible in the upper area of the barrel close to rear sight.

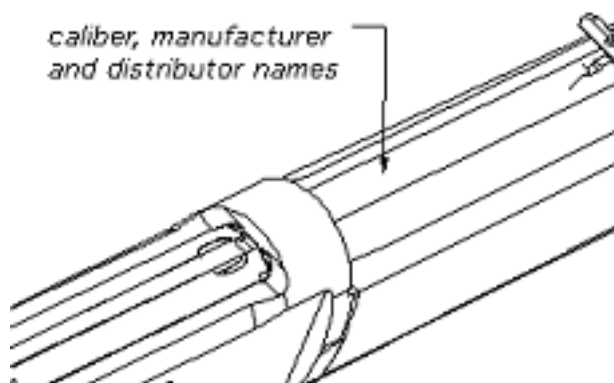

Lever Action main parts nomenclature

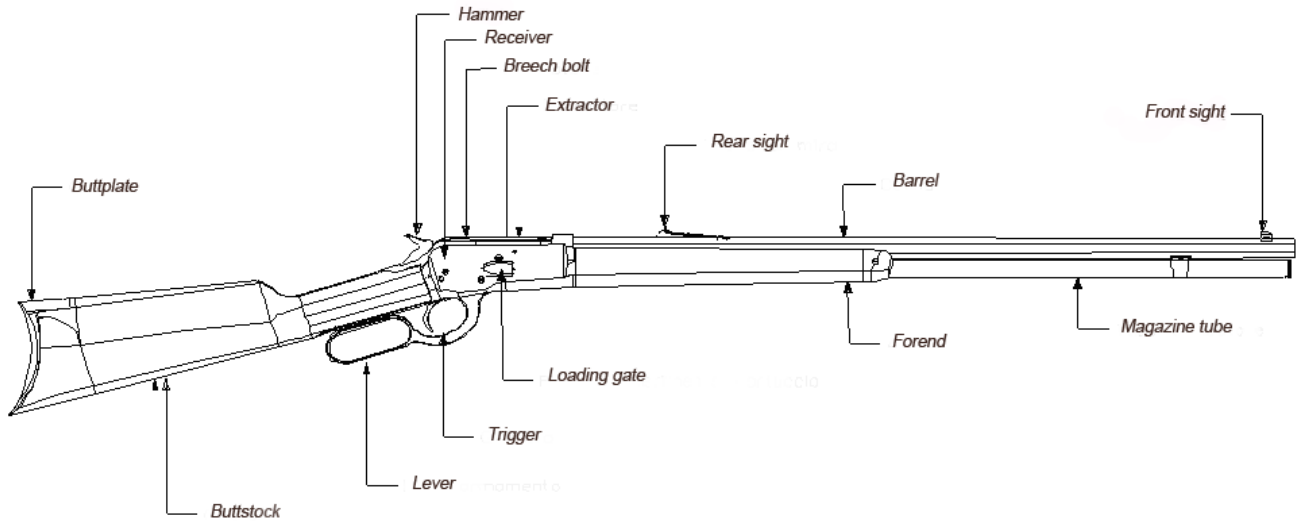

Lever Action Take Down

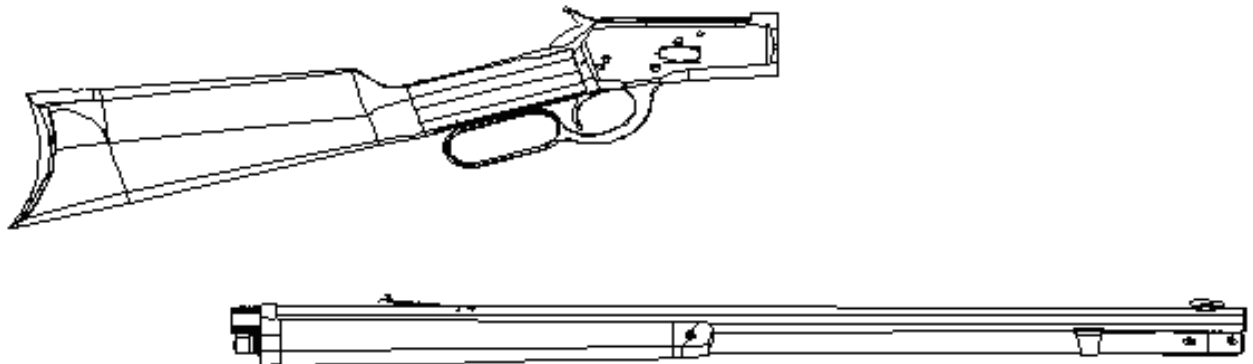

The 1892 and 1886 lever action models left a mark in the American history at the end of 19th century.

Armi Sport has reproduced a replica as close as possible to the original gun.

Magazine tube located below the barrel can take 7 to 14 shells according to caliber and model. (In the European version the number is limited to five due to local legislation). The safety (only half cock hammer) works the same as the original gun. Pay attention to safety. The Take Down version is extremely easy to transport thanks to the length reduction and furthermore allows the change of caliber with an interchangeable barrel (see chart).

These rifles are very well known also for the use in western movies.

AMMUNITION

NOTICE

WE SPECIFICALLY DISCLAIM RESPONSIBILITY FOR ANY DAMAGE OR INJURY WHATSOEVER OCCURRING IN CONNECTION WITH, OR AS THE RESULT OF, THE USE OF FAULTY, OR NONSTANDARD, OR “REMANUFACTURED” OR HANDLOADED (RELOADED) AMMUNITION, OR OF CARTRIDGES OTHER THAN THOSE FOR WHICH THE FIREARM WAS ORIGINALLY CHAMBERED.

- Death, serious injury, and damage can result from the use of wrong ammunition, bore obstructions, powder overloads, or incorrect cartridge components.
- Use only ammunition specifically recommended for your firearm (the caliber is specified on the barrel/cylinder/frame).
- Always use cartridges whose length is equal or inferior to that indicated on the barrel.
- Use only high quality, original factory manufactured ammunition whose pressure cannot be higher than the one stated by S.A.A.M.I. or C.I.P.
- Your gun has been designed for ammunition of a specific caliber – do not alter the barrel, chamber, caliber for which your gun was designed.
- Be sure you never mix ammunition.
- Firearms may be severely damaged, and serious injury to the shooter or others may result from any condition causing excessive pressure inside the chamber or barrel during firing. Excessive pressure can be caused by obstruction in the barrel, propellant powder overloads, or by the use of incorrect or defectively assembled cartridges. In addition, the use of a dirty, corroded or damaged cartridge can lead to a burst cartridge case and consequent damage to the firearm and personal injury from the sudden escape of high-pressure propellant gas within the firearm's mechanism.

Immediately stop shooting and check the barrel for a possible obstruction whenever:

- You have difficulty in, or feel unusual resistance in chambering a cartridge
- A cartridge misfires (does not go off)
- The mechanism fails to extract a fired cartridge case
- Unburned grains of propellant powder are discovered spilled in the mechanism
- A shot sounds weak or abnormal

In such cases it is possible that a bullet is lodged part way down the barrel. Firing a subsequent bullet into the obstructed barrel can damage the firearm and cause serious injury to the shooter or bystanders.

Bullets can become lodged in the barrel:

- If the cartridge has been improperly loaded without propellant powder, or if the powder fails to ignite. Ignition of the cartridge primer alone will push the bullet out of the cartridge case, but usually does not generate sufficient energy to expel the bullet completely from the barrel.
- If the bullet is not properly seated tightly in the cartridge case. When such a cartridge is extracted from the chamber without being fired, the bullet may be left behind in the bore at the point where the rifling begins. Subsequent chambering of another cartridge may push the first bullet further into the bore.
- If there is any reason to suspect that a bullet is obstructing the barrel, immediately unload the firearm and look through the bore. It is not sufficient to merely look in the chamber. A bullet may be lodged some distance down the barrel where it cannot easily be seen. If a bullet is in the bore, do not attempt to shoot it out by using another cartridge, or by blowing it out with a blank or one from which the bullet has been removed. Such techniques can generate excessive pressure, damage the firearm and cause serious personal injury. If the bullet can be easily removed with a wood or brass dowel, (using hand pressure only, never "hammer" a bullet lodged in the bore) clean any unburned powder grains from the bore, chamber and mechanism before resuming shooting. If the bullet cannot be dislodged by tapping it with a cleaning rod, take the firearm to a gunsmith.

- Dirt, corrosion, or other foreign matter on a cartridge can impede complete chambering and may cause the cartridge case to burst upon firing. The same is true of cartridges which are damaged or deformed.
- Don't oil cartridges, and be sure to wipe the chamber clean of any oil preservative before commencing to shoot. Oil interferes with the friction between cartridge case and chamber wall that is necessary for safe functioning, and subjects the firearm to stress similar to that imposed by excessive pressure.
- Use lubricants liberally on the moving parts of your firearm. Avoid excessive spraying of any aerosol gun care product, especially where it may get on ammunition. All lubricants, and aerosol spray lubricants in particular, can penetrate cartridge primers and cause misfires. Some highly penetrative lubricants can also migrate inside cartridge cases and cause deterioration of the propellant powder; on firing, the powder may not ignite. If only the primer ignites, there is a danger that the bullet may become lodged in the barrel.

The use of reloaded or improper ammunition voids the warranty.

INSTRUCTIONS FOR USE

Firmly shoulder your gun before firing, hold the forend, having the buttplate well against your shoulder to reduce recoil.

Chamber the cartridge swinging the lever, then close it completely. During this action, the shell will go from the magazine tube through the receiver and up in the barrel chamber.

Take aim and when on target, squeeze the trigger.

Now to extract the empty shell from the chamber, open the lever briskly. The extractor will eject the shell that will be thrown up and slightly on the right side.

While the shell is ejected, a new cartridge is coming into the receiver and when the lever is closed the loading cycle is completed.

During this phase strictly follow the recommendations shown in the "Warning" paragraph concerning the safety aspects for you and bystanders.

Loading the magazine

First check the caliber of the ammunition to be the same as indicated on the barrel.

Failure to follow this instruction can result in severe damage to your gun and possible serious injury to yourself or others.

With the muzzle pointed in a safe direction, the lever must be completely closed to load the magazine. The hammer must not be cocked. With thumb securing hammer pull the trigger and slowly lower the hammer.

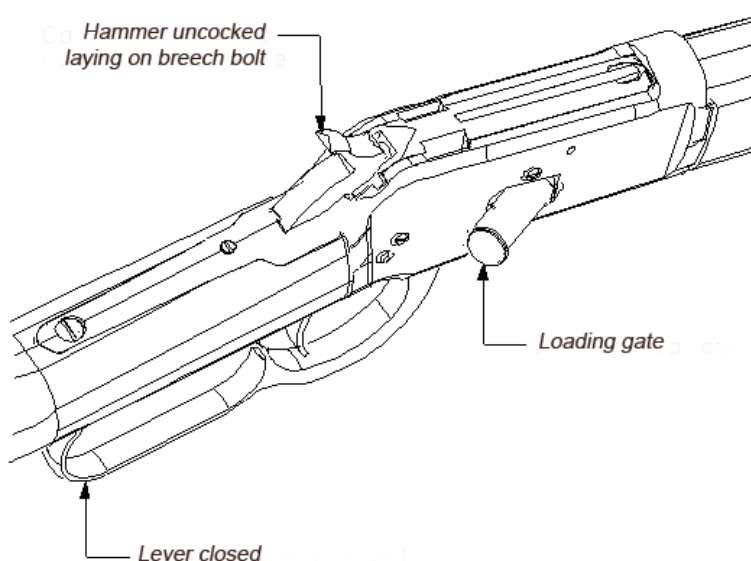

Press the loading gate inward with the tip of the first cartridge until all but the rim has entered the loading gate, then insert the next cartridge in the same manner, pushing the preceding cartridge into the magazine.

Repeat this procedure with each cartridge, but push the last cartridge past the end of the loading gate, allowing the gate to snap closed. Do not exceed the recommended capacity of the magazine.

WARNING: for a smooth loading, we advise to use FLAT NOSE cartridges. As to cartridges cal. 38 for model 1892, please make sure the minimum length is 39 mm (1,53 in).

Finger position when levering

Put the fingers (we suggest middle, ring and little fingers) in the loading lever loop. **IMPORTANT:** the forefinger must be always kept out of the triggerguard and away from the trigger not to risk an accidental discharge.

The thumb should be kept outward far from the hammer.

When the lever is completely forward you can see the shell going through the magazine to the receiver.

Close the lever also with firm and smooth action.

During this phase, the breech bolt has cocked the hammer.

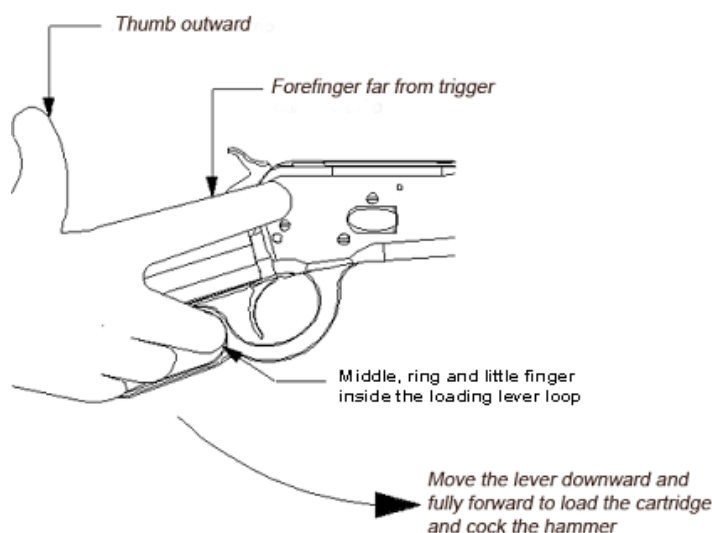

Hammer in safety position

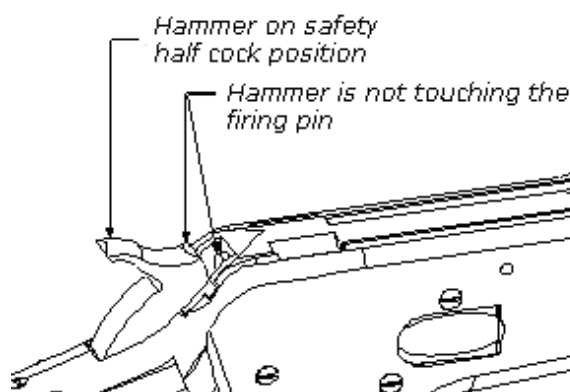
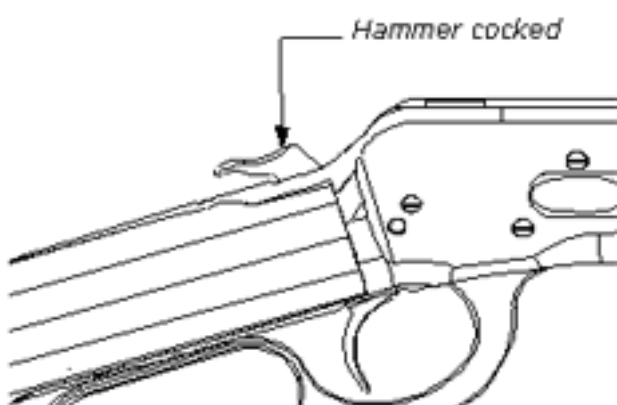

Hammer in safety position is strictly recommended when firing is not imminent and cartridge is chambered.

Hammer is at full cocked position when the action is cycled using the lever, now you can put in safety position. Place your thumb on the hammer and firmly hold it. While holding the hammer back, apply just enough pressure on the trigger to release it and gently lower the hammer. When the hammer is resting on the firing pin pull it slightly rearward until you hear the half cock click. This is the original safety position, if you pull the trigger, the hammer will not be released.

To start shooting you have to pull the hammer back to the full cock position.

Now you're ready to shoot.

Rear sight adjustment

The rear sight is manually adjustable to shoot higher or lower by moving the rear sight ramp by one or more notches.

This adjustment will allow the rear sight to be adjusted lower or higher. It's possible to adjust the rear sight for windage by following these steps: loosen the screw on the upper front side of the sight.

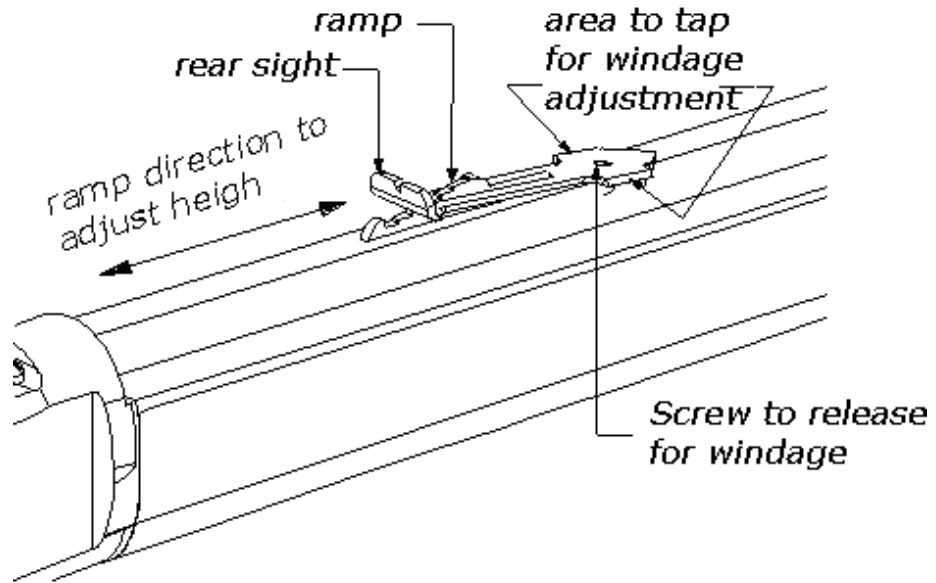

Take a non-marking brass, plastic or fiber hammer and gently tap the rear sight base to the left or to the right according to the direction you wish to move the point of aim. Tighten the screw again.

Front sight adjustment

Front sight is also adjustable by loosening the specific screw.

The front sight will move left or right direction.

When placed in correct position, tighten the screw again.

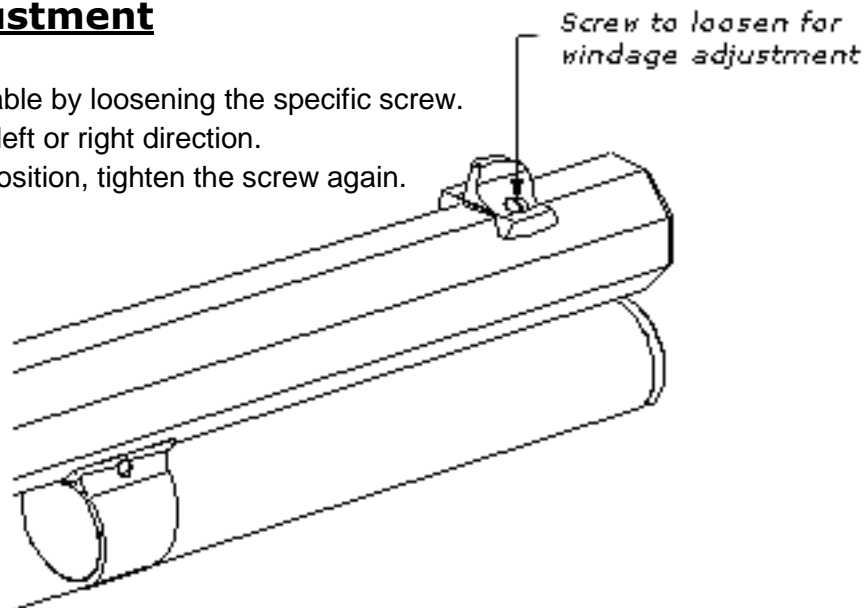

Main spring regulating screw

The power of the hammer percussion on the cartridge can be adjusted.

Use a screwdriver and work the screw shown in the drawing by tightening the screw the spring will be stronger. Loosening the screw the spring will be weaker.

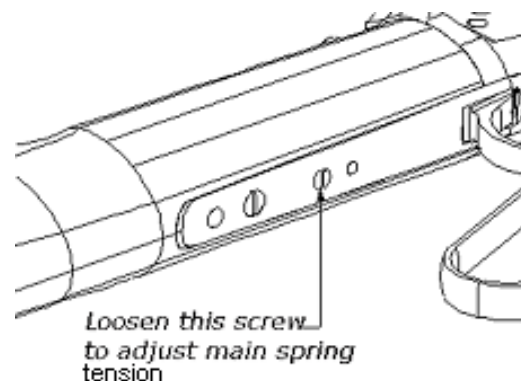

Take Down version

This version, previously described, maintain same way of use of the Lever Action 1892 but with barrel interchangeable.

Here is how to change or disassemble it.

1st phase: magazine tube disassembly

Open the lever under the magazine tube.

Rotate the lever counter clockwise.

During this operation the tube will slip off.

When the tube is completely unscrewed, open the finger lever and leave it open.

Note: light markings on the magazine tube resulting from disassembly are normal.

2nd phase: barrel rotation 90°

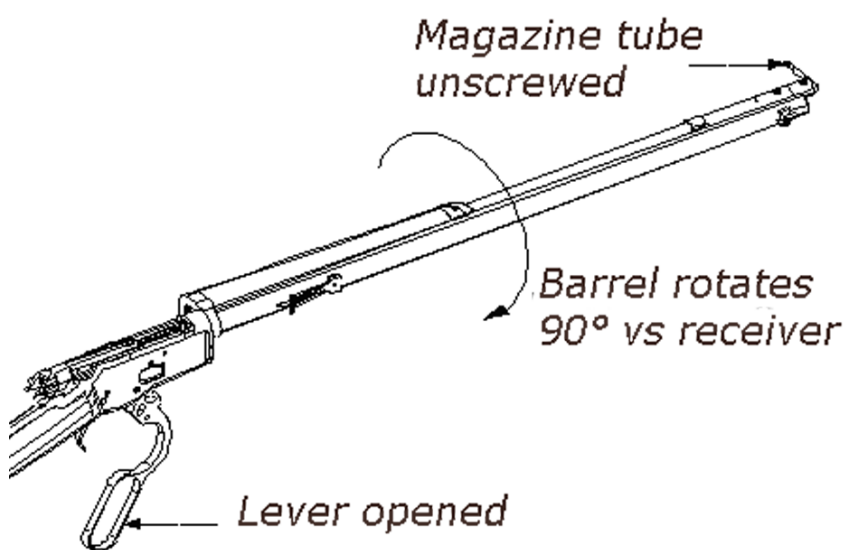
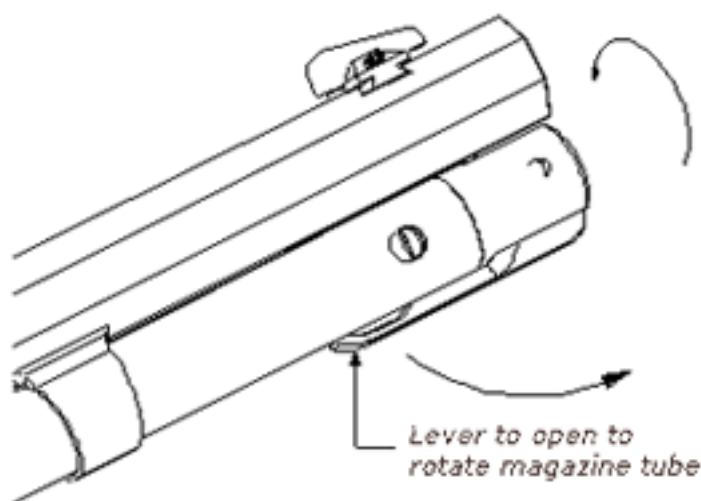

Hold the stock in one hand and hold the forearm with the other.

Twist firmly the forearm in clockwise direction so that the barrel and the forearm rotate 90°.

Now slip off the barrel. To reassemble the rifle repeat the process in the reverse order, keeping the lever open during the operation.

Magazine reduction removal

In Italy the Ministry of Interior has recently limited the maximum number of cartridges in the magazine for a rifle to be only five.

This rule has obliged us to use a magazine reduction.

In other countries, where this limitation is not required, the device may be removed.

Please check the drawing below carefully prior to proceeding with this operation. **WARNING:** the magazine reduction cannot and must not be removed in the countries where the law require this limit.

ARMI SPORT declines any responsibility on the violation of the device where there is such a rule, the person that will attempt with tampering will do it at his own danger and risk.

Please verify local legislation before any attempt of modification to the magazine capacity.

By model 1886, the plug can be removed by slightly turning it so that the indent can be removed from its socket in the barrel

Slide off the plug

3 - Unscrew the rod and take it off

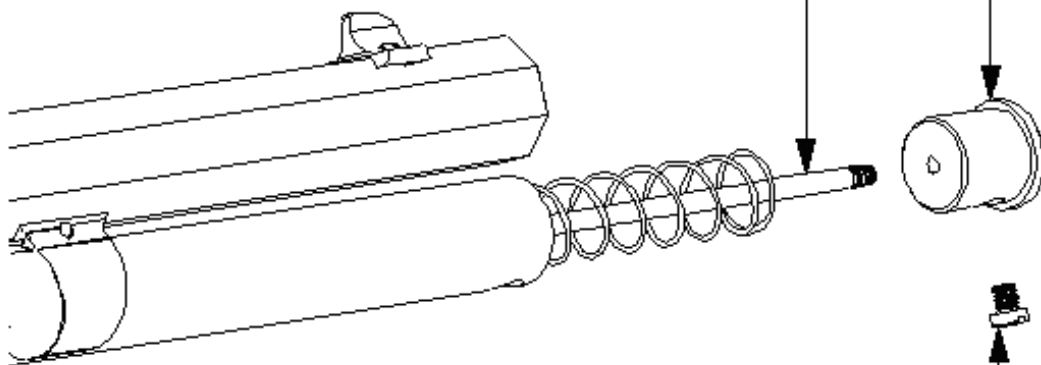

1 - Unscrew the screw

When the rod has been removed, replace the plug in its seat.
In the Take Down version there are two screws to disassemble.

SAFETY FEATURES

NEVER ASSUME THE GUN IS UNLOADED. You can never be sure a gun is unloaded unless you check that the charger is not in place/ the cartridge chamber / magazine tube / cylinder is completely empty.

Never rely solely on mechanical features alone - always be extremely careful, use safe gun handling practices, and avoid situations which could lead to an accident.

This firearm is equipped with several safety features which, if properly employed, can minimize the danger of accidental discharge.

ORDINARY & EXTRAORDINARY MAINTENANCE

- Before performing any sort of maintenance, make sure the firearm is unloaded.
- By “ordinary maintenance” we refer to measures the user should take to keep the gun in good working conditions.
- An “Extraordinary maintenance” implies the replacement of broken parts and therefore disassembling the gun. In this case only authorized personnel or a qualified gunsmith should handle the task.
- Also a long period of heavy use or inactivity requires an extraordinary maintenance; your gun should be taken to a qualified gunsmith to have the action disassembled for professional cleaning and lubrication.
- Your gunsmith will advise the best lubricant for the good maintenance of your gun.
- Do not leave oil residues when cleaning and lubricating your firearm.
- Make sure that the mechanism of the weapon is easy; if it starts to stiffen, or if corrosion is starting on some essential parts, you should bring your gun to competent, professional personnel.
- Do not use pure silicon or lanolin.
- In the following pages you will find exploded views with a list of all parts. When ordering parts, it's important to specify date of purchase, serial number, model, caliber and item reference of the part/s needed.
- If the gun has a problem that you cannot fix, **DO NOT FIRE**, send it to an authorized center for a check-up. If you try to fix it personally, you may put in serious danger yourself and the people near you. Always pay great attention and handle the gun very carefully, in order to avoid terrible accidents which may change your life and that of others.

- **Warning: Always use a cleaning rod from the chamber end of the barrel.**

TROUBLESHOOTING TIPS

The shell does not go into the magazine tube	The lever is not fully closed	Close the lever firmly
	The magazine tube is already full	Screw in magazine tube
	In Take Down version the magazine tube is not completely screwed in.	
The shell does not go out of the magazine tube	In Take Down the magazine tube is not completely screwed in.	Screw in magazine tube
	Magazine tube spring jamming	Slightly hit the magazine tube to disengage it
	Foreign body inside the tube	Disassemble the tube, clean it from residual of powder or other foreign matter.
The shell does not go into the chamber	Wrong caliber, too large	Check the caliber on the barrel and use the correct one indicated on the lever
	Wrong maneuver in working the lever	Remove the shell in incorrect position and repeat the operation paying attention that the lever will make a complete run forward to lift up correctly the shell for chambering
	Barrel entrance damaged	Remove any eventual residue or rust in the chamber
The rifle doesn't shoot	Wrong caliber	Check the caliber on the barrel and use the correct ammunition
	Defective primer in the cartridge	Manually remove the unexploded cartridge
	Lever not correctly closed	Firmly close the lever
	Weak hammer hit	Increase main spring tension with the regulating screw. See specific chapter.
The empty shell is not ejected	The extractor is broken	Change the extractor
	Shell deformed and stuck	If caliber is correct but the shell is stuck because deformed, the chamber could be damaged. It is necessary to bring the gun to a qualified gunsmith to verify the integrity of the barrel
	The ejector is broken	The ejector must be changed, it is advisable that a qualified gunsmith performs this complex work
Take Down Version: the barrel doesn't rotate to be slipped off	Magazine tube not completely unscrewed	Un-screw completely and slip off the magazine tube
	The lever is not opened	Check the lever is opened.
	Wrong rotation to disassemble the barrel	The rotation of the barrel must be anticlockwise.

Rear sight for 1892 ALASKAN and 1886 KODIAK

Models 1892 Alaskan and 1886 Kodiak are supplied with a Skinner sight. The barrel is predrilled to mount a rail type Weaver mod. 61M.

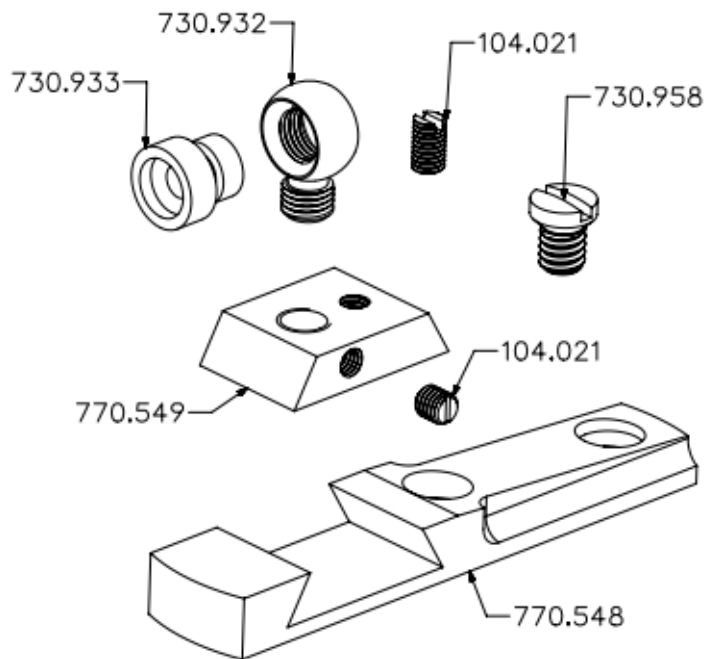

SKINNER SIGHT

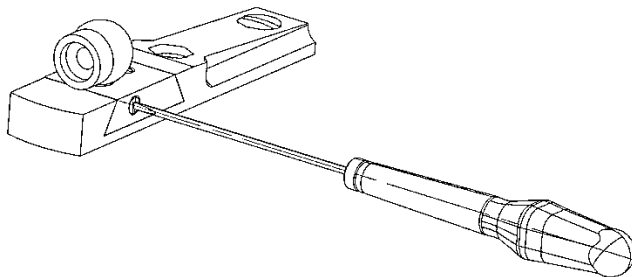

Elevation is adjusted by loosening the lock screw on the left hand side and turning the aperture stem up or down on its threads, then locking it in place with the screw.

Windage is adjusted by loosening the lock screw on top, then moving the dovetail left or right (may require tapping with a brass punch), then locking back in place with the lock screw.

NOTE: *Always move the rear sight in the direction you want to move bullet impact on the target. Example: You are shooting to the left, move the rear sight to the right. You are shooting low, move the aperture stem up.*

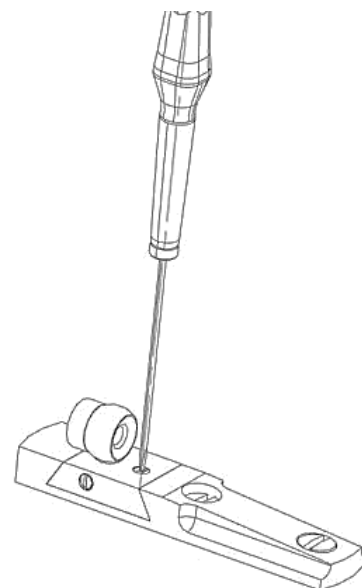

EXPLODED VIEW MODEL 1892

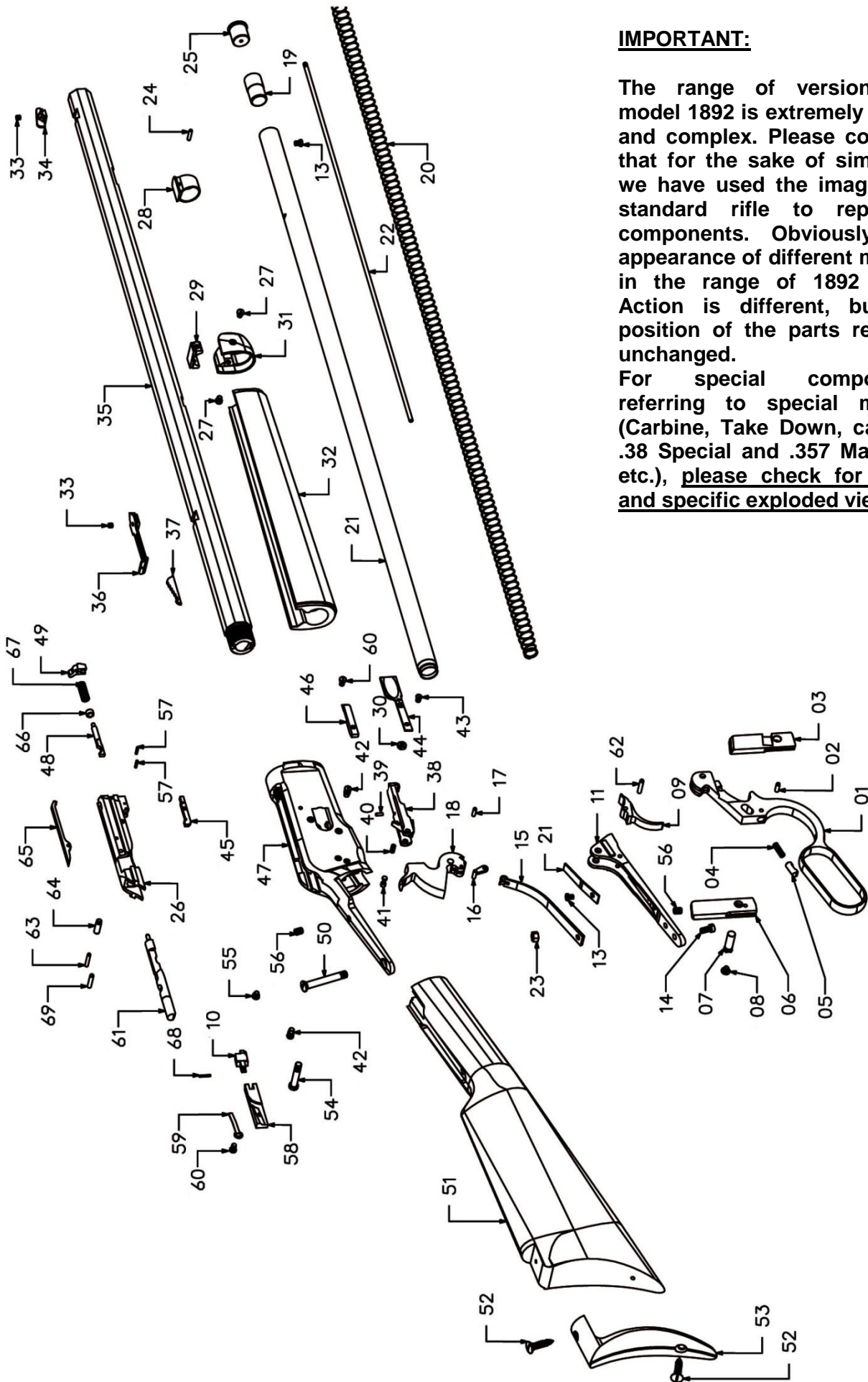

IMPORTANT:

The range of versions for model 1892 is extremely varied and complex. Please consider that for the sake of simplicity we have used the image of a standard rifle to represent components. Obviously, the appearance of different models in the range of 1892 Lever Action is different, but the position of the parts remains unchanged.

For special components referring to special models (Carbine, Take Down, calibers .38 Special and .357 Magnum, etc.), please check for notes and specific exploded views.

PARTS LIST MODEL 1892

<u>REF.</u>	ALL MODELS	CALIBERS .38SP .357MAG	ALASKAN MODELS	DESCRIPTION	NOTES	QTY
23	150.001	150.001	150.001	Nut M6 blued		1
35	SEE CHART	SEE CHART	SEE CHART	BARREL		1
04	720.012	720.012	720.012	Spiral spring 4x13x0.5		1
40	720.060	---	720.060	Spiral spring 3,3x7x0,4		1
15	721.097	721.097	721.097	Main spring WIN		1
12	721.098	721.098	721.098	Trigger spring WIN		1
59	721.102	721.128	721.102	Cartridge stop spring thick. 0,7		1
52	730.267	730.267	730.267	butt plate screw	A	2
64	730.458	730.458	730.458	ejector - lever pin		1
62	730.460	730.460	730.460	firing pin- trigger PIN		1
05	730.461	730.461	730.461	friction stud		1
02	730.462	730.462	730.462	friction stud stop pin		1
07	730.464	730.464	730.464	locking bolt pin		1
08	730.465	730.465	730.465	locking bolt pin screw		1
54	730.466	730.466	730.466	hammer screw		1
17	730.467	730.467	730.467	Stirrup pin		1
43	730.468	730.468	730.468	spring cover screw		1
55	730.469	730.469	730.469	lever- breech bolt hole screw		1
50	730.471	730.471	730.471	receiver tang screw		1
13	730.472	730.472	730.472	Trigger spring screw WIN		1
27	730.472	730.472	730.472	Trigger spring screw WIN		2
14	730.473	730.473	730.473	1892 Main spring screw		1
56	730.475	730.475	730.475	dioptr base hole screw		2
60	730.477	730.477	730.477	cartridge guide screw		2
42	730.478	730.478	730.478	carrier screw		2
41	730.479	--	730.479	carrier stop		1
24	730.487	730.487	---	Magazine ring pin	B	1
30	730.492	730.492	730.492	Loading gate nut - 1892		1
38	770.205	770.313	770.205	1892 Carrier .44-40		1
46	770.210	770.314	770.210	1892 Cartridge guide right		1
01	770.213	770.213	770.576	LEVER	G	1
03	770.216	770.216	770.578	Locking bolt, right		1
06	770.217	770.217	770.579	Locking bot, left		1
11	770.226	770.226	770.452	Trigger plate		1
18	770.227	770.227	770.455	1892 Hammer		1
09	770.228	770.228	770.454	1892 Trigger		1
16	770.229	770.229	770.229	Stirrup		1
47	SEE CHART	SEE CHART	770.577	Receiver/frame		1
28	770.238	770.238	770.222	Magazine ring 1892 L.A.	F	1
51	SEE CHART	SEE CHART	780.129	STOCK		1
32	SEE CHART	SEE CHART	780.130	FOREND		1
53	SEE CHART	SEE CHART	270.066	BUTTSTOCK		1
29	790.181	790.181	790.181	TENNON 1892	C	1
31	790.184	790.184	790.210	NOSE CAP 1892	D	1
44	<u>O98.184</u>	<u>O98.220</u>	<u>O98.184</u>	<u>Loading gate assy 1892</u>		<u>1</u>
ASBLY	721.103	721.103	721.103	loading gate spring		1
ASBLY	730.493	730.493	730.493	Loading gate rivet		2
ASBLY	770.239	770.316	770.239	loading gate base		1

REF.	ALL MODELS	CALIBERS .38SP .357MAG	ALASKAN MODELS	DESCRIPTION	NOTES	QTY
	<u>O98.185</u>	<u>O98.185</u>	<u>O98.185</u>	<u>Ejector Assembly</u>		<u>1</u>
67	720.070	720.070	720.070	Spiral spring 5,9x17,5x1		1
66	730.457	730.457	730.457	ejector collar		1
49	770.212	770.212	770.212	ejector		1
48	770.214	770.214	770.214	Ejector pin WIN		1
	<u>O98.186</u>	<u>O98.222</u>	<u>O98.331</u>	<u>BREECH BLOCK Assembly</u>		<u>1</u>
57	130.001	130.001	130.001	Coiled spring pin light duty 1,5x8		2
63	130.076	130.076	130.076	Coiled spring pin 2,5x14		1
69	130.080	130.080	130.080	Roller 3x14		1
61	770.206	770.206	770.206	Firing pin WIN		1
45	770.231	770.231	770.231	ejector lever stop		1
26	770.204	770.319	770.458	1892 .44-40 BREECH BOLT		1
65	770.230	770.318	770.230	Extractor WIN CAL.44-40		1
	<u>O98.188</u>	<u>O98.223</u>	<u>O98.188</u>	<u>Cartridge guide Assembly, left</u>		<u>1</u>
68	730.587	730.587	730.587	cartridge stop pin		1
10	770.209	770.321	770.209	cartridge stop		1
58	770.211	770.320	770.211	cartridge guide left		1
				<u>Magazine assembly</u>		<u>1</u>
20	SEE CHART	SEE CHART	720.071	Spiral spring 11,6x552x0,70		1
19	SEE CHART	SEE CHART	730.483	Magazine follower 1892		1
25	SEE CHART	SEE CHART	730.449	Magazine plug		1
21	SEE CHART	SEE CHART	730.984	1892 L.A. 16" magazine tube 45LC		1
22	SEE CHART	SEE CHART	---	1892 L.A. 16" magazine reduction rod		1
13	SEE CHART	SEE CHART	---	Magazine screw/pin 1892		1
			720.035	Spiral spring 4.8x13x0.45		
			730.484	MAGAZINE DISASS. LEVER SCREW		
			130.045	Sphere dia.5		
			770.221	MAGAZINE DISASSEMBLY LEVER		
	<u>O98.216</u>	<u>O98.216</u>	<u>---</u>	<u>Front Sight Assembly</u>		<u>1</u>
33	730.481	730.481	---	Front & rear sight grub screw oct. brl		1
34	770.247	770.247	770.559	1892 L.A. RIFLE Front sight	E	1
	<u>SEE CHART</u>	<u>SEE CHART</u>	<u>SEE DRW</u>	<u>Rear Sight Assembly</u>		<u>1</u>
33	<u>SEE CHART</u>	<u>SEE CHART</u>	<u>SKINNER</u>	Front & rear sight grub screw oct. brl		1
37	<u>SEE CHART</u>	<u>SEE CHART</u>	<u>REAR</u>	Rear sight leaf		1
36	<u>SEE CHART</u>	<u>SEE CHART</u>	<u>SIGHT</u>	Rear sight		1

NOTE	REF.	DESCRIPTION
A	52	For PISTOL models substituted by 730.078
B	24	Only for LA rifle; not for carbine and TD models
C	29	Not av. for Carbine and Pistol; av. for Pistol TD
D	31	Not av. for Carbine and Pistol; av. for Pistol TD
E	34	Not av. for Carbine; substituted by 770.346 for Pistol models
F	28	Substituted by 770.254 for Carbine and Pistol; by 770.222 for TD
G	1	Substituted by 770.327 for Rio Bravo models

CHART – Different components

Barrel	Caliber	Item Code	Ref.	Ref.	Ref.	Ref.	Ref.	Magazine Assembly	Rear Sight Assembly	
			135	147	151	132	153			
			Barrel	Receiver	Stock	Forend	Buttstock			
16"	.45LC	<u>920.130</u>	710.201	770.232	780.046	780.071	790.178	<u>O98.242</u>	<u>O98.215</u>	1892 L.A. RIFLE
20"	.45LC	<u>920.063</u>	710.150	770.232	780.046	780.071	790.178	<u>O98.191</u>	<u>O98.290</u>	
24"	.45LC	<u>920.064</u>	710.151	770.232	780.046	780.047	790.178	<u>O98.190</u>	<u>O98.290</u>	
20"	.44-40	<u>920.056</u>	710.147	770.232	780.046	780.071	790.178	<u>O98.191</u>	<u>O98.290</u>	
24"	.44-40	<u>920.052</u>	710.141	770.232	780.046	780.047	790.178	<u>O98.190</u>	<u>O98.290</u>	
16"	.44Mag	<u>920.206</u>	710.246	770.232	780.046	780.071	790.178	<u>O98.242</u>	<u>O98.215</u>	
20"	.44Mag	<u>920.289</u>	710.259	770.232	780.046	780.071	790.178	<u>O98.191</u>	<u>O98.290</u>	
24"	.44Mag	<u>920.290</u>	710.253	770.232	780.046	780.047	790.178	<u>O98.190</u>	<u>O98.290</u>	
20"	.38-40	<u>920.153</u>	710.197	770.232	780.046	780.071	790.178	<u>O98.191</u>	<u>O98.290</u>	
24"	.38-40	<u>920.155</u>	710.198	770.232	780.046	780.047	790.178	<u>O98.190</u>	<u>O98.290</u>	
20"	.38Sp	<u>920.117</u>	710.179	770.324	780.046	780.071	790.178	<u>O98.226</u>	<u>O98.290</u>	
24"	.38Sp	<u>920.119</u>	710.180	770.324	780.046	780.047	790.178	<u>O98.225</u>	<u>O98.290</u>	
16"	.357Mag	<u>920.162</u>	710.202	770.324	780.046	780.071	790.178	<u>O98.243</u>	<u>O98.215</u>	
20"	.357Mag	<u>920.129</u>	710.184	770.324	780.046	780.071	790.178	<u>O98.226</u>	<u>O98.290</u>	
24"	.357Mag	<u>920.131</u>	710.185	770.324	780.046	780.047	790.178	<u>O98.225</u>	<u>O98.290</u>	
20"	.45LC	<u>920.067</u>	710.155	770.255	780.066	780.052	790.193	<u>O98.192</u>	<u>O98.240</u>	1892 L.A. CARBINE
20"	.44-40	<u>920.057</u>	710.153	770.255	780.066	780.052	790.193	<u>O98.192</u>	<u>O98.240</u>	
20"	.44Mag	<u>920.204</u>	710.245	770.255	780.066	780.052	790.193	<u>O98.192</u>	<u>O98.240</u>	
20"	.38-40	<u>920.157</u>	710.199	770.255	780.066	780.052	790.193	<u>O98.192</u>	<u>O98.240</u>	
20"	.38Sp	<u>920.121</u>	710.181	770.337	780.066	780.052	790.194	<u>O98.228</u>	<u>O98.240</u>	
20"	.357Mag	<u>920.133</u>	710.186	770.337	780.066	780.052	790.193	<u>O98.228</u>	<u>O98.240</u>	1892 "RIO BRAVO"
20"	.45LC	<u>920.100</u>	710.155	770.255	780.066	780.052	790.193	<u>O98.192</u>	<u>O98.240</u>	
20"	.44-40	<u>920.103</u>	710.153	770.255	780.066	780.052	790.193	<u>O98.192</u>	<u>O98.240</u>	
20"	.44Mag	<u>920.205</u>	710.245	770.255	780.066	780.052	790.193	<u>O98.192</u>	<u>O98.240</u>	
20"	.38-40	<u>920.108</u>	710.199	770.255	780.066	780.052	790.193	<u>O98.192</u>	<u>O98.240</u>	
20"	.38Sp	<u>920.106</u>	710.181	770.337	780.066	780.052	790.193	<u>O98.228</u>	<u>O98.240</u>	1892 TAKE DOWN RIFLE
20"	.357Mag	<u>920.104</u>	710.186	770.337	780.066	780.052	790.193	<u>O98.228</u>	<u>O98.240</u>	
20"	.45LC	<u>920.065</u>	710.149	770.215	780.046	780.071	790.178	<u>O98.189</u>	<u>O98.290</u>	
24"	.45LC	<u>920.066</u>	710.148	770.215	780.046	780.047	790.178	<u>O98.187</u>	<u>O98.290</u>	
24"	.44-40	<u>920.053</u>	710.134	770.215	780.046	780.047	790.178	<u>O98.187</u>	<u>O98.290</u>	
20"	.44-40	<u>920.054</u>	710.146	770.215	780.046	780.071	790.178	<u>O98.189</u>	<u>O98.290</u>	
20"	.38-40	<u>920.147</u>	710.195	770.215	780.046	780.071	790.178	<u>O98.189</u>	<u>O98.290</u>	
24"	.38-40	<u>920.149</u>	710.196	770.215	780.046	780.047	790.178	<u>O98.187</u>	<u>O98.290</u>	
20"	.38Sp	<u>920.111</u>	710.177	770.315	780.046	780.071	790.178	<u>O98.224</u>	<u>O98.290</u>	
24"	.38Sp	<u>920.113</u>	710.178	770.315	780.046	780.047	790.178	<u>O98.227</u>	<u>O98.290</u>	
20"	.357Mag	<u>920.123</u>	710.182	770.315	780.046	780.071	790.178	<u>O98.224</u>	<u>O98.290</u>	1892 LA Pistol
24"	.357Mag	<u>920.125</u>	710.183	770.315	780.046	780.047	790.178	<u>O98.227</u>	<u>O98.290</u>	
12"	.45LC	<u>920.185</u>	710.235	770.255	780.080	780.052	760.116	<u>O98.287</u>	<u>O98.240</u>	
12"	.44-40	<u>920.292</u>	710.251	770.255	780.080	780.052	760.116	<u>O98.287</u>	<u>O98.240</u>	
12"	.45LC	<u>920.182</u>	710.228	770.435	780.080	780.071	760.116	<u>O98.283</u>	<u>O98.240</u>	1892 T.D. Pistol
12"	.44Mag	<u>920.211</u>	710.248	770.435	780.080	780.071	760.116	<u>O98.283</u>	<u>O98.240</u>	
12"	.357Mag	<u>920.183</u>	710.316	770.315	780.080	780.071	760.116	<u>O98.474</u>	<u>O98.240</u>	
16"	.45LC	<u>920.321</u>	710.327	See List	See List	See List	See List	See List	See List	1892 ALASKAN
20"	.45LC	<u>920.322</u>	710.328	See List	See List	See List	See List	See List	See List	
16"	.44Mag	<u>920.311</u>	710.325	See List	See List	See List	See List	See List	See List	
20"	.44Mag	<u>920.312</u>	710.326	See List	See List	See List	See List	See List	See List	

See below exploded components for Magazine and Rear Sight Assemblies

Exploded view CAL 38-357 extra components

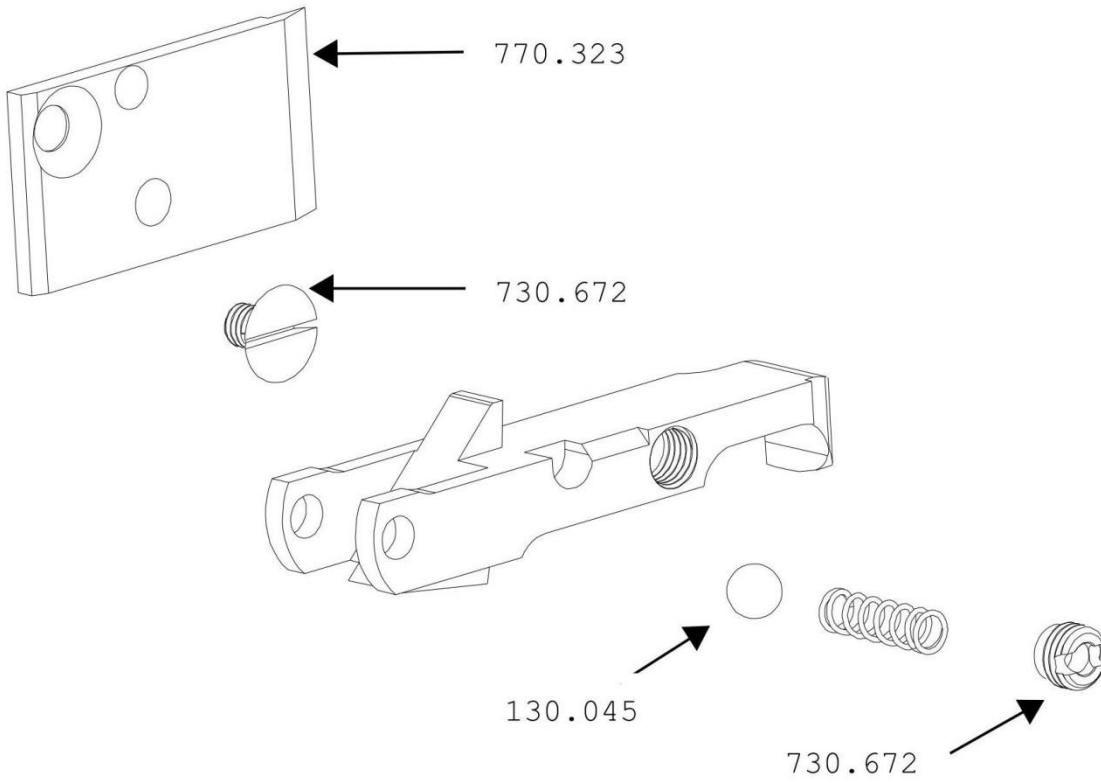

Exploded view TAKE DOWN extra components

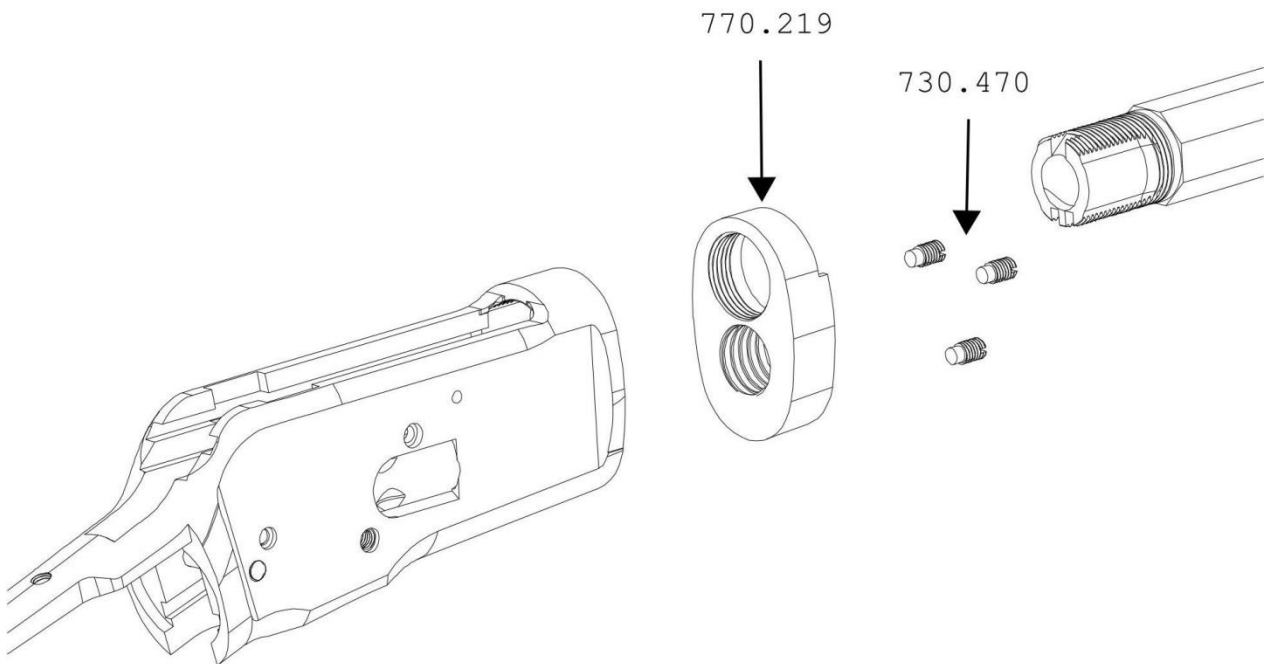

Exploded view -Carbine extra components

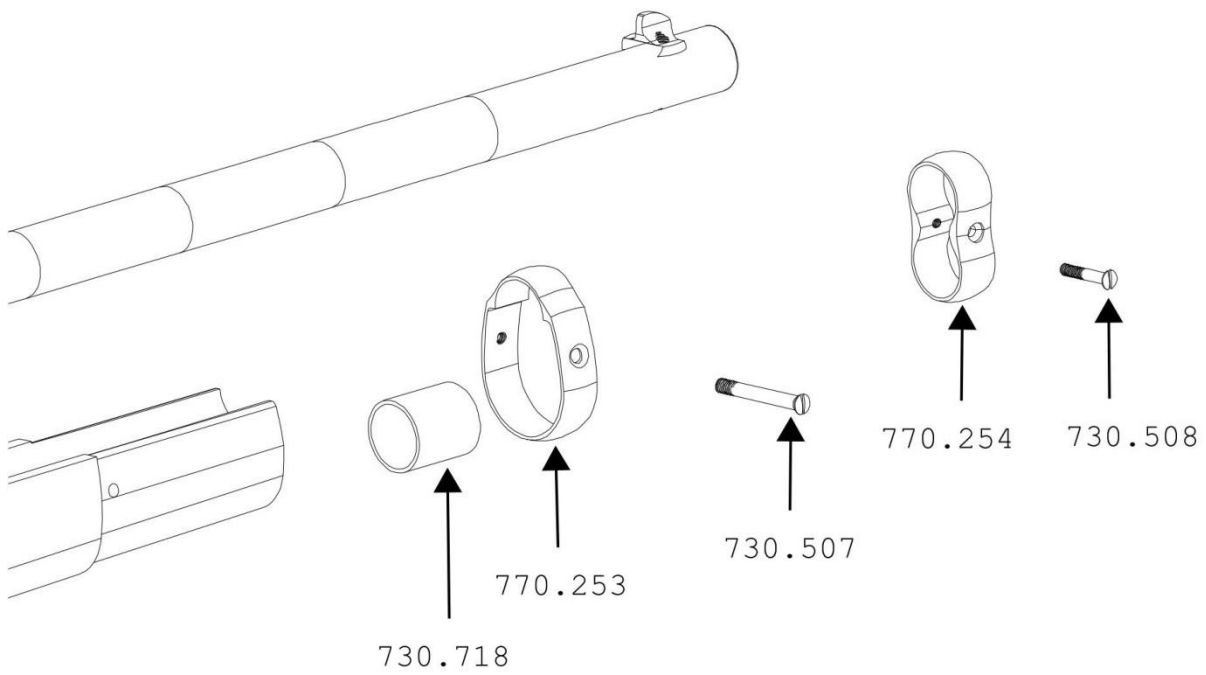

Exploded view -Carbine saddle ring extra components

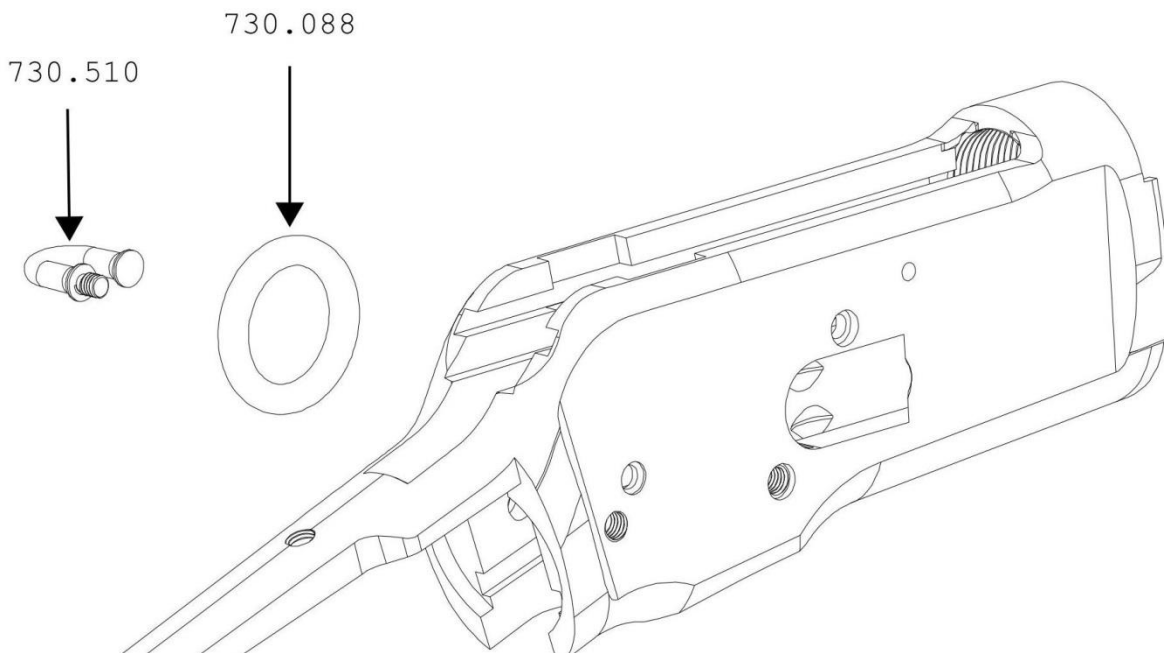

Exploded components for Magazine and Rear Sight Assemblies

Magazine Assbly	Spring	Follower	Plug for magazine tube	Magazine tube	Limitation 5 shot	Screw magazine tube	Spiral spring 4.8x13x0.45	Magazine disassembly lever screw	Sphere dia.5	Magazine disassembly lever
O98.187	720.071	730.483	730.449	730.448	730.494	730.472	720.035	730.484	130.045	770.221
O98.189	720.073	730.483	730.449	730.503	730.506	730.472	720.035	730.484	130.045	770.221
O98.190	720.071	730.483	730.486	730.485	730.631	730.826				
O98.191	720.073	730.483	730.486	730.502	730.628	730.826				
O98.192	720.073	730.483	730.486	730.511	730.628	730.826				
O98.224	720.091	730.629	730.449	730.627	730.506	730.472	720.035	730.484	130.045	770.221
O98.225	720.092	730.629	730.486	730.630	730.631	730.826				
O98.226	720.091	730.629	730.486	730.633	730.628	730.826				
O98.227	720.092	730.629	730.449	730.632	730.494	730.472	720.035	730.484	130.045	770.221
O98.228	720.073	730.629	730.486	730.640	730.628	730.826				
O98.242	720.097	730.483	730.486	730.679	730.678	730.826				
O98.243	720.098	730.629	730.486	730.677	730.678	730.826				
O98.283	720.071	730.483	730.449	730.751	730.756	730.472	720.035	730.484	130.045	770.221
O98.287	720.071	730.483	730.486	730.755	730.756	730.826				
O98.474	720.091	730.629	730.449	730.963	730.756	730.472	720.035	730.484	130.045	770.221

REAR SIGHT ASSBLY	Front sight screw	Rear sight leaf	Rear sight	Rear sight spring pin	Rear sight leaf	Rear sight base	Rear sight slide	Sphere d.2
O98.215	730.481	770.237	790.180					
O98.240	730.481	720.032	730.215	730.291	770.343	770.344	770.345	130.021
O98.290	730.481	770.237	770.437					

Exploded view - Rear sight extra components

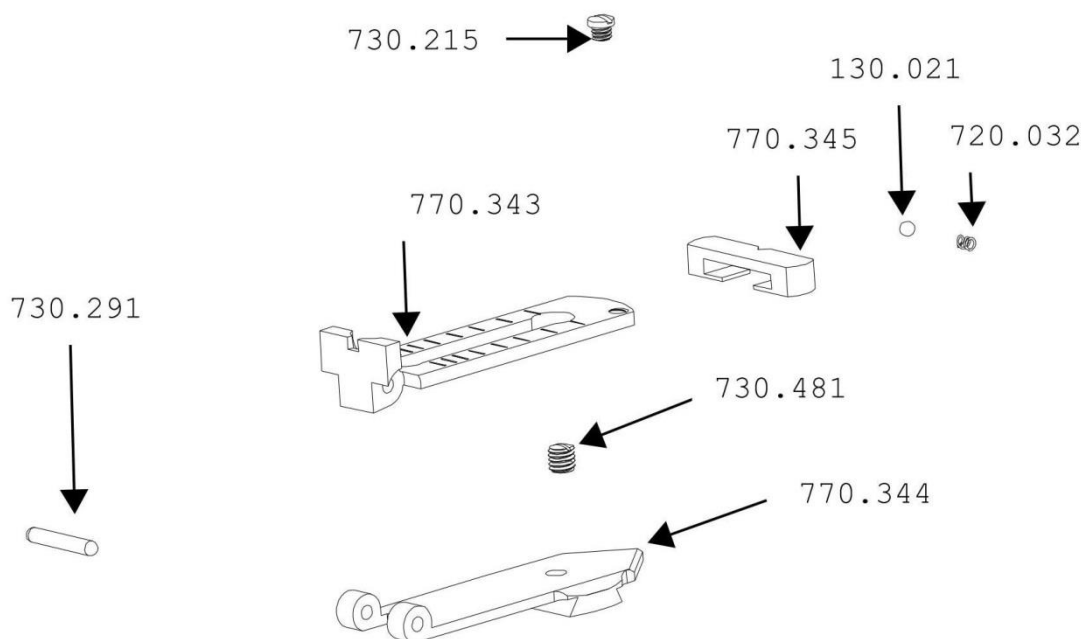

EXPLODED VIEW MODEL 1886

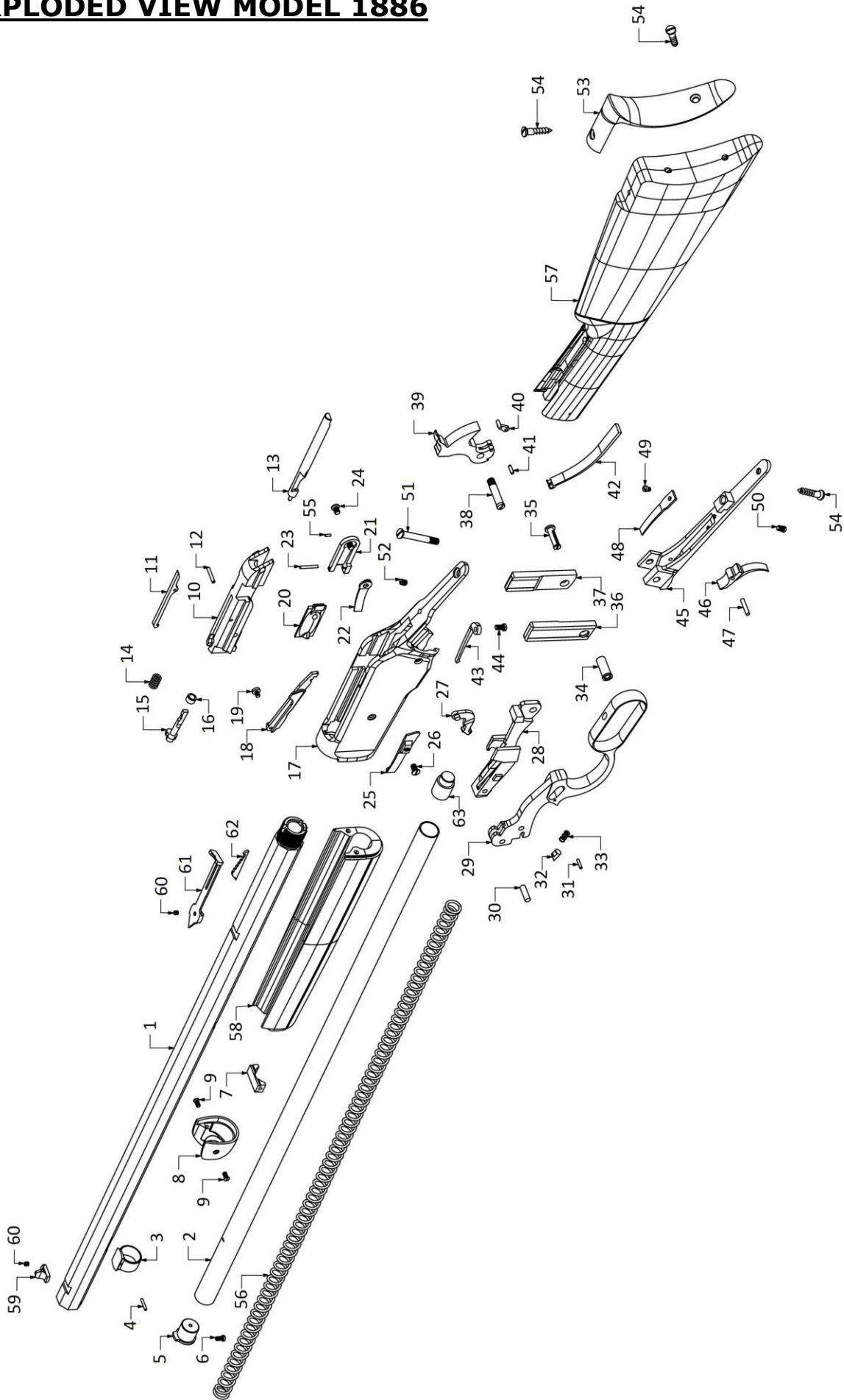

PARTS LIST MODEL 1886

REF	Standard	KODIAK	DESCRIPTION	QTY	REF	Standard	KODIAK	DESCRIPTION	QTY
1	710.295	710.312	BARREL	1	34	730.861	730.861	FINGER LEVER BUSHING	1
2	730.884	730.926	LOADING TUBE	1	35	730.860	730.860	LEVER BUSHING PIN	1
3	770.510	---	MAGAZINE RING	1	36	770.490	770.539	LOCKING BOLT - RIGHT	1
4	730.487	---	Magazine ring pin	1	37	770.491	770.540	LOCKING BOLT - LEFT	1
5	730.865	730.927	MAGAZINE PLUG	1	38	730.851	730.851	HAMMER SCREW	1
6	730.859	730.928	LOADING TUBE SCREW	1	39	770.502	770.541	HAMMER	1
7	770.496	770.496	TENNON	1	40	770.229	770.229	Stirrup	1
8	790.219	790.224	NOSE CAP	1	41	730.467	730.467	Stirrup pin	1
9	730.858	730.858	NOSE CAP SCREW	2	42	721.137	721.137	MAIN SPRING	1
10	770.497	770.534	BREECH BLOCK	1	43	721.138	721.138	CARRIER SPRING	1
11	770.511	770.535	EXTRACTOR	1	44	730.855	730.855	CARRIER SPRING SCREW	1
12	730.459	730.459	extractor - breech bolt pin	1	45	770.495	770.542	TRIGGER PLATE	1
13	730.886	730.886	FIRING PIN	1	46	770.504	770.543	TRIGGER	1
14	720.120	720.120	EJECTOR SPRING	1	47	730.888	730.888	TRIGGER PIN	1
15	730.890	730.890	EJECTOR	1	48	721.136	721.136	TRIGGER SPRING	1
16	730.895	730.895	EJECTOR RING	1	49	730.849	730.849	TRIGGER SPRING SCREW	1
17	770.492	770.536	RECEIVER 1886 LA	1	50	730.852	730.852	TRIGGER SeRING ADJ. SCREW	1
18	770.500	770.500	CARTRIDGE GUIDE	1	51	730.857	730.857	TANG SCREW	1
19	730.850	730.850	CARTRIDGE GUIDE SCREW	1	52	730.856	730.856	DIOPTR GRUB SCREW	1
---	098.386	098.415	Cartridge loading gate assy WIN 1886	1		098.387	098.416	STOCK ASSY WIN 1886 OCTAG BARREL	1
20	790.220	790.223	LOADING GATE - MOBILE PART	1	53	790.218	ONLY	BUTT PLATE	1
21	770.501	770.537	LOADING GATE - FIXED PART	1	54	730.908	FULL	BUTT PLATE SCREW	2
22	721.135	721.135	LOADING GATE SPRING	1	57	780.098	ASSBLY	STOCK FOR OCT. BARREL 1886 LA	1
23	730.863	730.863	LOADING GATE PIN	1	55	730.893	730.893	LOADING GATE STOP PIN	1
	730.893	730.893	LOADING GATE STOP PIN (assembled)		56	720.121	720.121	SPRING 680X14,1X1	1
24	730.853	730.853	LOADING GATE SCREW	1	58	780.099	780.115	FOREND 1886	1
25	790.221	790.221	CARTRIDGE STOP	1		098.216		1892 L.A. Front Sight	1
26	730.854	730.854	CARTRIDGE STOP SCREW	1	59	770.247	770.559	1892 L.A. RIFLE Front sight	1
27	770.499	770.499	CARRIER HOOK	1	60	730.481	---	Front & rear sight grub screw oct. brl	1
28	770.509	770.509	1886 CARRIER	1		098.403	SEE	1886 LA Rear Sight Assembly	1
29	770.494	770.538	LEVER	1	61	770.514		REAR SIGHT	1
30	730.887	730.887	BREECH BLOCK LEVER PIN	1	62	770.237		Rear sight leaf	1
31	130.005	130.005	ROLL 2X9,8	1		730.481		Front & rear sight grub screw oct. brl	1
32	730.889	730.889	LEVER PIN	1	63	730.864	63	MAGAZINE FOLLOWER	1
33	720.033	720.033	Spiral spring 5,1x10x0,5	1					

WARRANTY CONDITIONS

The manufacturer guarantees that our products are scrupulously checked against defects in materials, workmanship and aesthetical and functioning problems.

In case you find a defect in one of our products, you should immediately contact the DEALER/SHOP/GUNSMITH where you have bought your gun. The seller will indicate the conditions for the repair, which will be either made directly by them or through our assistance.

ATTENTION: end users are not allowed to ship any gun directly to the manufacturer for repair, either under guarantee or against payment. Transportation of weapons is strictly regulated and the documents which are required can solely be issued by companies with specific authorization.

1. The manufacturer guarantees, for a year after the purchase date, the free substitution of parts for defects which have been found out during use: wear of parts which shouldn't be subject to wear, or excessive wear of parts subject to wear. The customer will have to give evidence of the purchase date with a bill or other valid proof.
2. In case the defect under cover of guarantee is not repairable, The manufacturer will provide for a free substitution of the weapon.

THE MANUFACTURER RESERVES THE RIGHT OF DEFINING THE TYPE OF DEFECT OF THE FIREARM, AND THEREFORE TO STATE WHETHER THE DEFECT IS COVERED BY GUARANTEE

The manufacturer's decision will be fair but final.

The manufacturer will be allowed a timing of 60 days for repair under guarantee, and 90 days for free substitution.

We strongly recommend that you keep the receipt or proof of purchase for any The manufacturer product

Should the manufacturer become aware of a defect of a product during the guarantee period, the defective part will be replaced free of charge.

The guarantee does not cover parts subject to wear and corrosion

ATTENTION: delivery expenses to and from the service center are not covered by the guarantee and will be charged to the customer.

THE GUARANTEE IS VOID IN CASE:

- Inadequate ammunition has been used (any ammunition but those commonly on sale, reloaded ammunition, different from caliber and specification indicated on the firearm barrel)
- The firearm failed to be provided proper maintenance and cleaning
- The firearm has been modified without our prior consent
- Unauthorized, inadequate or incorrect repairs have been carried out
- Non original spare parts were used
- Parts subject to wear and corrosion
- Damage (improper use of the gun by the user)
- Expired guarantee

In the above cases the repair, if carried out, will be charged to the customer

In case, for any valid reason, you do not have the possibility to obtain repair under guarantee at the shop where you bought the firearm, you may contact us directly; we will indicate a local dealer to support you with the repair file:

USA - Phone: +1-937-835-5000
CANADA (Murray Charlton) – Phone +1-778.426.3884
e-mail: murray.mdcent@gmail.com
REST OF THE WORLD - Phone: +39/030/9749065
e-mail: info@chiappafirearms.com

**This instruction manual must always follow the firearm,
also in case of change of ownership**

Procedure for the use of warranty

REGISTER your firearm in the proper section of our website:

<http://www.chiappafirearms.com/registration>

CONTACT the gunshop where the product was bought, or the Chiappa Firearms facility for USA, Canada or Rest of the World as indicated above. You will receive an NDR number and the instructions to return the gun.

FILL IN the attached form, which will accompany the return firearm. Don't forget to include the NDR number, a description of the defect and a copy of the proof of the purchase indicating the purchase date.

SHIP the weapon to the gun shop (or to the service center) in its original packing, according to the instructions you have received.

ATTENTION: the returned firearm must be protected with adequate packaging; any damages occurred during transportation and handling will be the customer's responsibility

REPAIR UNDER GUARANTEE

NdR NDR : _____

**Please write in the above box
the Repair Authorization Number**

1. Customer data:

- Name: _____
- Address : _____
- Town : _____
- ZIP Code : _____
- Phone : _____ Available from ____ to ____
- Fax : _____
- Email address: _____

2. Product information:

- Model : _____
- Serial number : _____

3. Gun Shop - dealer:

- Purchase date : _____
- Dealer name : _____
- Dealer address: _____

4. Description of defect:

Documents to attach: Proof of purchase with date



Via Milano 2
25010 Azzano Mella (BS)
Italy

www.chiappafirearms.com
email: info@chiappafirearms.com