

ANDERSON RIFLES 80% LOWER RECEIVER JIG -SUGGESTED METHOD-

Please begin by reviewing the assembly drawing below and identifying each of the components included in the kit. This document is intended to give general guidelines on completing the Anderson Rifles 80% lower receiver. Always use proper personal protective equipment and machine tool safety practices when working to complete the lower receiver. Anderson Manufacturing is not responsible for machining errors or injuries incurred during the completion of the 80% lower receiver. Read the complete document before proceeding.

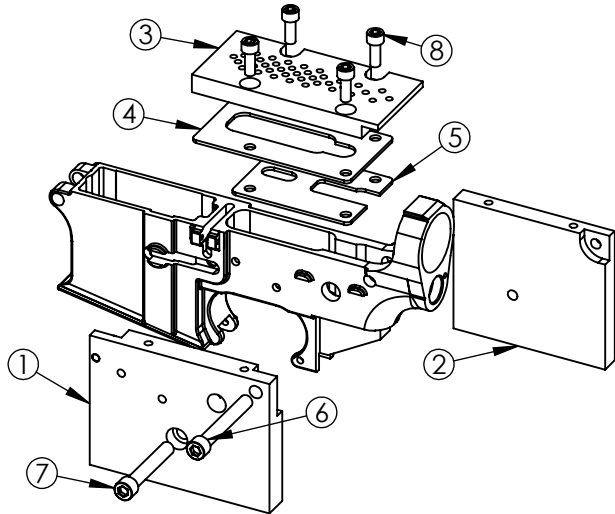

ITEM #	DESCRIPTION	QTY.
1	Fixture Plate #1	1
2	Fixture Plate #2	1
3	Fixture (Drill) Plate #3	1
4	Template #1	1
5	Template #2	1
6	1/4"-20 SHCS 1-3/4" length	1
7	1/4"-20 SHCS 1-1/2" length	1
8	10-24 SHCS 1/2" length	4
9	1/8", 5/32", 5/16", 3/8", 31/64" Drill Bits	5

Step #1: Assemble the fixture as shown above using "Fixture Drill Plate #3" (3)
(Only one template bolts to the top at a time- (3) (4) OR (5))
Align and square the face of (2) with the edge of (3) and fasten the 4 screws (8), this ensures the features you machine are in the correct location & square

- Drill each of the 38 holes with the 1/8" drill provided to a depth of .25"
- Remove drill plate (3), drill the holes within the outlined area to $\phi 1/8" \nabla 1.250"$
- Drill the solid shaded holes to $\phi 1/8" \nabla .630"$

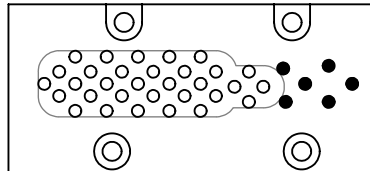

Step #2: (Note: the Fixture Drill Plate #3 is still removed from the fixture- the image below is for reference to the 1/8" pre drilled holes that are now in your 80% lower receiver)

- **A.)** Drill the 2 holes shown below to $\phi 3/8" \nabla 1.25"$, (or preferably $\phi 7/16"$ -not included)
-It is recommended to take multiple steps when drilling to final size. (use 5/32, 5/16, and then 3/8)
- **B.)** After the 2 holes are completed to final size and depth, continue by following the same process on the 12 holes identified below (Step 2B) working left to right
- **C.)** Drill the 2 holes shown below (right) to 31/64"
This step is not required on the Anderson 80% lower, this portion comes pre-machined

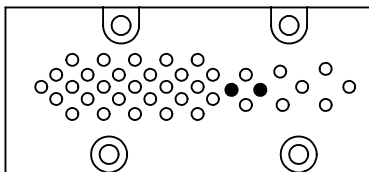

Step 2A

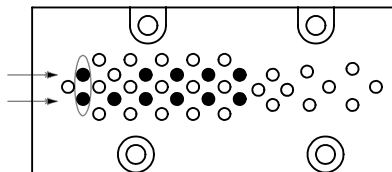

Step 2B

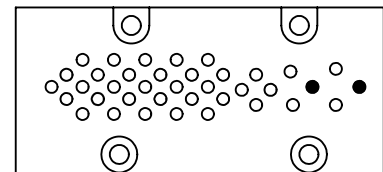

Step 2C

ANDERSON RIFLES 80% LOWER RECEIVER JIG -SUGGESTED METHOD-

Step #3: Install template #1④

- Use this template to help guide removing the scallops that remain from the previous drilling process. Remove excess material from floor of pocket created by drill taper to $\nabla 1.250''$. Possible material removal methods for this step include files, milling, die grinders or other rotary tooling.

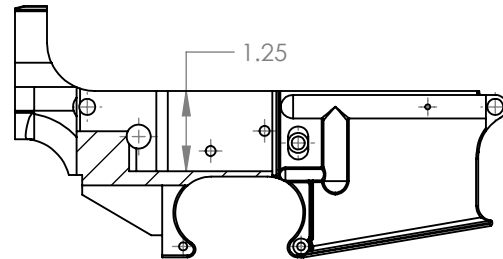
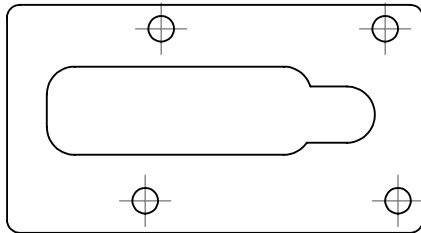

Step #4: Install template #2⑤

- A.)** Drill 2 thru holes (one on each end of the trigger hole slot shown below) to $\varnothing 5/16$. Remove the material that remains between the 2 holes to match the slot in template #2
- B.)** Use the profile (identified as Step 4B) to help guide removing the scallops that remain from the previous drilling process. Remove excess material from floor of pocket to $\nabla .630''$

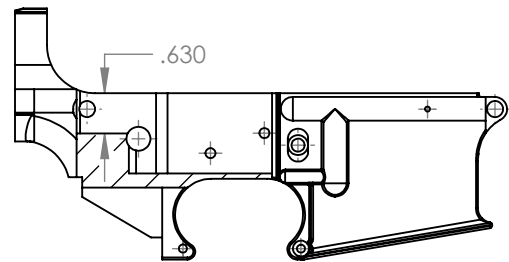
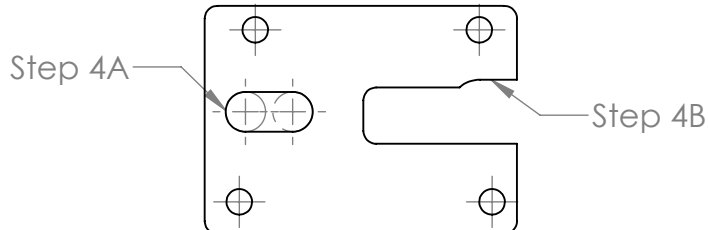

Step #5: Complete by drilling the holes in Fixture Plate #1①

- Drill 2 thru holes $\varnothing 5/32''$ for hammer/trigger pin, and 1 thru hole $3/8''$ for safety select

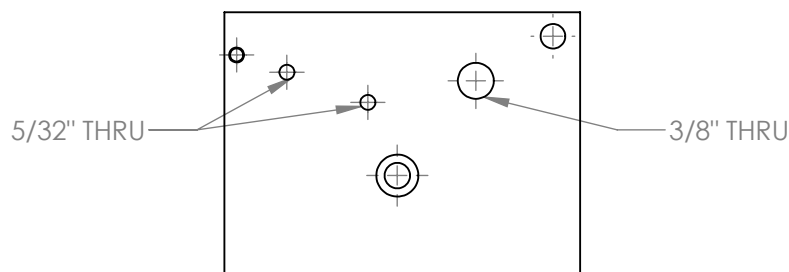

Step #6: Disassemble the fixture and inspect your work. The dowel pin in Fixture Plate #1 has a tight fit to ensure location of the fixture while machining, take care when removing this plate as to not damage the receiver. While assembling the components into the lower receiver ensure the components move freely and as expected without excessive tolerances. Thoroughly test your firearm in a safe location after assembly.