



MTP20

www.emperorfirearms.com
Importer: Sarac Distributors LLC Fort Myers, FL
Phone: 239-561-3444 Fax: 347-892-3428

**INSTRUCTION MANUAL
FOR PUMP ACTION SHOTGUNS**

Warnings	1-3
Introduction	4
Manual Safety Operation	5
Ammunition	6
Operating Instructions	7-10
-Opening the Bolt	7
-Checking For And Cleaning Bore Obstructions	7
-To Check The Barrel For Obstructions	7
-Clearing A Bore Obstruction	7
-Closing The Bolt	8
-Loading The Shotgun	8
-Feeding A Shell From The Magazine Into The Chamber	9
-Single Loading The Chamber Without Shells In The Magazine	9
-Firing The Shotgun	9
-Unloading The Shotgun	10
Disassembly Instructions	10-12
-Disassembly of Barrel From Receiver	10
-Disassembly Of Bolt From Receiver	11
-Disassembly Of Trigger Assembly From Receiver	11
-Disassembly Of Magazine Blocker	12
Cleaning Your Shotgun	12-16
-Cleaning The Bore / Outside Of The Barrel	13
-Cleaning The Choke Tubes / Muzzle Breaks / The Receiver	14
-Cleaning The Bolt / The Slide And Forearm Assembly	15
-Cleaning The Magazine / The Trigger Assembly	15
-Cleaning The Forearm And Butt Stock and rust prevention and removal	15-16
Assembly Instructions	16-17
-Assembly Of Trigger Assembly To Receiver	16
-Assembly Of Bolt To Receiver	16
-Assembly Of Barrel To Receiver	16
-Assembly Of Magazine Blocker To Magazine Tube	17
Storing Your Shotgun	17
Parts List	18
Exploded View Diagrams	19-20
Warnings Continued	21-24
Additional Views	25
External Mag Tube Spring For Auto Bolt Return	26
Legal Notice	27
Warranty Page	28

SAFETY WARNINGS

FIREARMS ARE DANGEROUS WEAPONS, WHICH CAN CAUSE SERIOUS INJURY OR DEATH. WHEN USING ANY FIREARM, SAFETY MUST BE YOUR FIRST AND ONLY CONCERN. FIREARM SAFETY IS YOUR SOLE RESPONSIBILITY.

Always keep this manual with your firearm. Make sure you understand all the operational instructions, safety procedures and warnings in this manual before you handle the firearm. If there's anything you don't understand, do not handle firearm, and write to us. If you sell, lend or give the firearm to another, make sure this manual goes with firearm. Obtain free firearm manual from current importer or from SARAC DISTRIBUTORS LLC.

ALWAYS TREAT YOUR FIREARM AS IF IT WERE LOADED. Always point the barrel in a safe direction! Use the manual safety button as outlined in this manual. Never move the safety to "FIRE" position until you are ready to fire. Never point a firearm at or near somebody else even if it's unloaded.

USE ONLY THE CORRECT AMMUNITION FOR YOUR FIREARM. Use only the correct gauge and length ammunition for your PTP12 Pump Action Shotgun as stamped on the right side of the barrel.

MAINTAIN YOUR FIREARM. Keep the barrel clean and free of obstructions. Clean your firearm regularly and have it inspected periodically to make sure it is mechanically correct and functioning properly. Worn or damaged parts can be dangerous. The owner is fully responsible on keeping this firearm maintained with routine checkups with qualified gunsmiths.

NEVER TOTALLY DEPEND ON A MECHANICAL SAFETY. It is not a substitute for proper gun handling. Like all mechanical devices like safety are subject to breakage or malfunction from wear or abuse or dirt or corrosion or user did not fully engage safety or repair, or lack of maintenance or any combinations of factors beyond the control of manufacturer. Manufacturer has made these firearms with the highest quality materials and workmanship and safety is the sole responsibility of the owner.

NO MECHANICAL SAFETY IS "CHILDPROOF" OR "FOOLPROOF". No safety ever invented can be relied upon to prevent an accidental shooting by a determined child or a grownup that "playing" with a gun.

TREAT EVERY GUN AS IF IT WERE LOADED, a safety is a mechanical device and can fail.

Always keep the safety on the "ON" position until you are ready to fire and the muzzle is pointing at the target.

Make sure that you understand how all controls work before you attempt to load the firearm.

Keep the muzzle pointed in a safe direction and your finger off the trigger when operating the safety. Malfunctions which may cause a gun to fire when safety is engaged or disengaged are rare but can happen. Even if an accidental firing should occur, nobody will be hurt if you follow this rule. You must follow this rule.

 **WARNING! THREE THINGS TO REMEMBER ABOUT SAFETIES**

1. NEVER TOTALLY DEPEND ON A MECHANICAL SAFETY. It is not a substitute for proper gun handling. Like all mechanical devices, a safety is subject to breakage and malfunction from wear or abuse or dirt or corrosion or user did not fully engage safety or repair, or lack of maintenance or any combinations of factors beyond the control of the manufacturer. Manufacturer has made these firearms with the highest quality materials and workmanship and safety is the sole responsibility of the owner.

2. No mechanical safety is "childproof" or "foolproof". No safety ever invented can be relied upon to prevent accidental shooting by a determined child or grown up person "playing" with a gun.

3. Treat every gun as if you expect the mechanical safety to not work. You will be astounded at how cautious you become and how little tolerance you will have for the complacency of others.

Never attempt to load or unload any firearm inside a vehicle, building or other confined space (except a properly constructed shooting range). Enclosed areas offer no completely safe direction in which to point the firearm because you don't know what is behind the walls. When hunting in the fields or woods constantly monitor where everybody is. Properly position yourselves, don't let other shooters get behind you or in front of you or out of your view, creating a deadly situation. As always, point in a safe direction. Always keep the safety on the "ON" position until you are ready to fire and the muzzle is pointing at the target.

When shooting, full eye and ear protection is mandatory at all times. Shooters and spectators must wear shooting glasses and sound suppressor to prevent eye injury and hearing loss. Vision loss and hearing impairment can occur with only one moment of non-protection.

SAFETY MEASURES: Put check mark next to each warning and safety measure when understood.

- Always point the firearm in a safe direction even though it may be unloaded. Do not point the gun at anything you do not intend to shoot. Never ever horseplay while handling a gun.
- Keep your finger away from the trigger when operating any other part of the gun's mechanism.
- Keep the safety "ON" until you are ready to fire. Treat gun with caution and always point in a safe direction.
- Keep your fingers away from the muzzle. Never pull a gun toward you by the muzzle.
- Be sure the barrel is clear of obstructions never assume, always check.
- Keep your gun unloaded when not in use.
- Always aim at a safe target, taking care that it does not conceal any other object. Be sure of your target and what lies behind, beyond, or near before you pull the trigger. Never shoot at sounds. To avoid ricochets, do not shoot at a flat, hard surface, curved surface, or at water.
- Store guns and ammunition separately, prevent access by children and others. Must be under lock and key. Guns should always be unloaded when stored.
- Never carry a loaded gun inside a vehicle, house, camp, or public place. When transporting the gun keep the gun "on safe" and unloaded. Never climb a tree or fence, or jump a ditch with a loaded gun.
- Never rely on any anyone's words that the gun is "on safe" or unloaded. Always check to see if the gun is "on safe" and unloaded when getting it from another person or storage.
- Never drink alcoholic beverages or use drugs before handling firearms or during shooting. Always use eye & hearing protection and make sure bystanders are also similarly protected.
- Although the firearm itself does not contain any lead, it fires ammunition containing lead or lead compounds, which are known to be dangerous to your health. Take protective health measures when shooting or when cleaning firearms. Avoid exposure to the lead while handling and wash your hands after contact. Proper air ventilation is **necessary** when shooting indoors or cleaning the firearm.
- Use proper ammo type only, malfunction, injury, or death will result from the use of faulty, incorrect type, size, gauge, non-standard, re manufactured, hand loaded, reloaded ammunition, old ammunition, or damaged ammunition. Because of the poor or **nonexistent** quality control of companies or people, overloads and underloads may occur. Following safety rules will save your life or the life of someone else.
- Know the range of your ammunition, shotgun pellets can travel for 800 yards; shotgun slugs have a range up to 5 miles. Learn and know about the capabilities of ammunition you use.

Pump Action Shotgun

The PTP12 Pump Action Shotgun is a manually operated slide action shotgun capable of feeding and firing target and hunting loads up to 3 inch. The picture below shows the main parts of the PTP12 Pump Action Shotgun. There might be slight differences and additional features in some models, most notably the feature of a pistol grip or not. Please refer to this picture while reading this manual. It will aid in understanding the terminology.

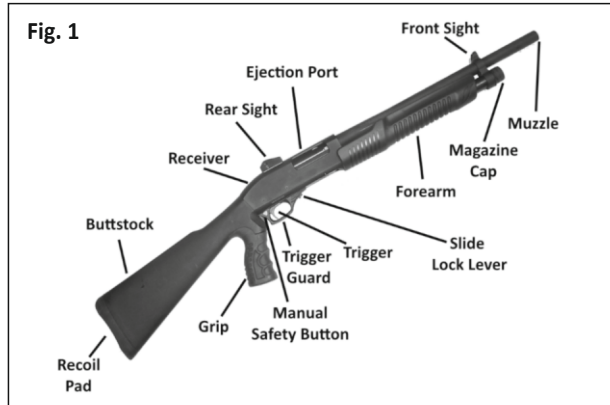

Operation of Safety

The manual safety on the PTP12 Pump Action Shotgun is a button type safety located on the rear of the trigger guard. When in proper condition and correctly engaged in the "SAFE" position, the manual safety blocks the trigger and prevents accidental discharge under normal usage.

**⚠ Never depend on any mechanical safety mechanism or ⚠
device to prevent the dangers of careless handling or pointing a
firearm in an unsafe direction**

To minimize the possibility of accidental discharge, it is strongly recommended that the safety always be placed in the "SAFE" position except when the shotgun is intended to be fired. To engage the manual safety, push the safety button from left to right with your thumb or index finger until it stops and stays in place in the "SAFE" position. The safety is now engaged.

(refer to Fig. 2) To disengage the manual safety, push the safety button through the trigger guard from right to left with your thumb or index finger until it stops and stays in place in the "FIRE" position. A red mark will be visible on the safety button to the left of the trigger guard in the "FIRE" position. The shotgun is now ready to fire.

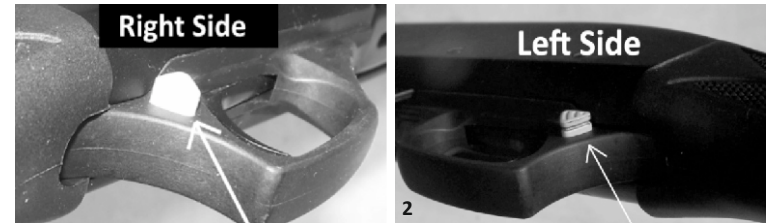

Manual safety is ON
Firearm is not ready to shoot

Manual safety if OFF
Firearm is not ready to shoot

When safety button is fully raised on right side = "SAFETY ON"
When safety button is fully raised on left side = "SAFETY OFF"

Ammunition

This Pump Action Shotgun is chambered only for shotgun shells in 2¾" and 3" lengths. Barrels marked for 3" shot shells can be safely used for both 2¾" and 3" shot shells. Please confirm the gauge of the shotgun before loading ammunition. The barrel or receiver is marked with the correct gauge. Chokes are crafted from high grade steel and are certified for steel shot through modified choke constrictions.

Use proper ammo type only, malfunction, injury, or death will result from the use of faulty, incorrect type, size, gauge, non-standard, re manufactured, hand loaded, reloaded ammunition, old ammunition, or damaged ammunition. Because of the poor or nonexistent quality control of companies or people, overloads and underloads may occur. Following safety rules will save your life or the life of someone else.

Use of incorrect or overloaded ammunition can result in death or serious injury and damage to your firearm due to excessive pressure. Even the strongest firearm can be "blown up" by excessive pressure. Use only factory-loaded ammunition

of the correct gauge and length for your shotgun as marked on the shotgun's barrel.

Emperor Firearms specifically disclaims responsibility for any injury or damage whatsoever occurring in connection with, or as a result of, or in the connection with, the use of faulty, or non-standard, any remanufactured or hand-loaded or reloaded ammunition, or of ammunition other than for which the firearm was originally chambered.

OPERATING INSTRUCTIONS

--Opening The Bolt--

1. Move the manual safety button to the "SAFE" position (refer to --Manual Safety Operation--)
2. Unload the gun (refer to --Unloading the Gun--)
3. While resting the butt pad against your thigh, grasp the shotgun forearm firmly with one hand.
4. With the other hand depress the slide lock lever identified in (FIG 2 PAGE 26) and pull the forearm rearward until the bolt stops at the rear of the receiver.

Never attempt to check for or clear a bore obstruction by loading a shot shell into the chamber of the barrel and firing! If there is a bore obstruction this will cause excessive pressures which may result in death or serious injury and damage to your shotgun.

--Checking for And Clearing Bore Obstructions--

The barrel of your shotgun should always be checked for obstructions before assembly, before loading and immediately following any occurrence in the field which might result in mud, dirt or other debris entering the bore.

Never attempt to check for or clear a bore obstruction by loading a shot shell into the chamber of the barrel and firing! If there is a bore obstruction this will cause excessive pressures which may result in death or serious injury and damage to your shotgun.

--To Check The Barrel For Obstructions--

1. Push a shotgun bore cleaning tool through the bore from the breech end until both the obstruction and the end of tool exit the muzzle.
2. If the obstruction cannot be easily cleared, contact an Authorized Emperor Firearms Distributor or Service Center.

--Closing The Bolt--

1. Move the manual safety button to the "SAFE" position (refer to --Manual Safety Operation--)
2. Hold the shotgun with one hand and grasp the forearm firmly with the second hand
3. Push the forearm all the way forward (If your shotgun has an optional action spring, forearm will move forward when you release it after pulling rearward)

If a shot shell is in the receiver loading port or in the barrel chamber and if the forearm is pushed forward closing the bolt and if manual safety is in the "FIRE" position, the shotgun is now ready to fire! Do not touch the trigger until you are ready to fire!

--Loading The Shotgun--

1. Move the manual safety button to the "SAFE" position (refer to --Manual Safety Operation--)
2. Open the bolt (refer to --Opening The Bolt--) and visually check to make sure no shell is in the receiver ejection port
3. Close the bolt (refer to --Closing The Bolt--)
4. Referring to Fig. 3, insert desired number of shot shells of the proper gauge and length into the magazine through the loading port by pushing each shell forward fully into the magazine until it is held in place by the shell latch.



--Feeding A Shell from The Magazine Into The Chamber--

1. Visually check the manual safety button to make sure it is in the "SAFE" position (refer to --Manual Safety Operation--)
2. Press the slide lock lever identified in Fig. 2, to release the bolt and pull the forearm to the rear to stage the shell
3. Push the forearm all the way forward to cycle the shell into the chamber (If your shotgun has an optional action spring, forearm will move forward when you release it after pulling rearward)

--Single Loading The Chamber Without Shells In The Magazine--

1. Move the manual safety button to the "SAFE" position (refer to --Manual Safety Operation--)
2. Open the bolt of the shotgun (refer to --Opening The Bolt--)
3. Drop a shot shell of the proper gauge and length (refer to --Ammunition--) directly into the ejection port, with the crimped end forward.
4. Push the forearm all the way forward (refer to --Closing The Bolt--) closing the bolt and feeding the shell into the chamber (If your shotgun has an optional action spring, forearm will move forward when you release it after pulling rearward)

--Firing The Shotgun--

1. With a shot shell in the chamber of the barrel, and keeping the muzzle of the shotgun pointed in a safe direction and your fingers out of the trigger guard and away from the trigger, move the manual safety button to the "FIRE" position (refer to --Manual Safety Operation--)
2. Hold the recoil pad snugly to your shoulder and carefully point the muzzle of the shotgun at your intended target
3. Squeeze (pull) the trigger with steadily increasing pressure until the shotgun fires
4. Unless an immediate second shot is intended, immediately remove your finger from the trigger, move the manual safety button to the "SAFE" position, unload the shotgun

--Unloading The Shotgun--

1. Move the manual safety button to the "SAFE" position (refer to -- Manual Safety Operation--)
2. Pull the forearm rearward to extract any shell from the chamber
3. Push the forearm forward to feed and chamber the next shell (If your shotgun has an optional action spring, forearm will move forward when you release it after pulling rearward)
4. Repeat steps 2 and 3 until the magazine is empty
5. Visually confirm that there are no shot shells remaining in the magazine or the chamber



-Disassembly Instructions-

-always wear safety glasses, watch for anything with spring tension-

--Disassembly Of Barrel From Receiver--

1. Move the manual safety button to the "SAFE" position (refer to -- Manual Safety Operation--)
2. Unload the shotgun (refer to --Unloading The Shotgun--)
3. Close the bolt by moving the forearm forward

4. Unscrew the magazine cap by turning it in a counter clock-wise direction until easily detached (refer to Fig. 4)
5. Remove the barrel by grasping firmly and pushing forward (in the direction of the muzzle) until the barrel tang is clear of the receiver ring.

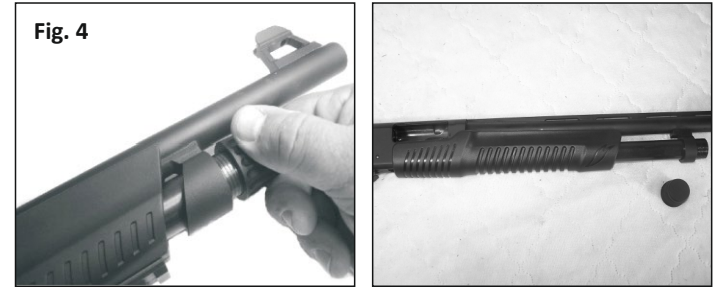

Fig. 4

--Disassembly Of Bolt From Receiver--

-wear safety glasses-

1. Pull forearm to rear to cock hammer.
2. Remove barrel (refer to --Disassembly Of Barrel From Receiver--)
3. Remove forearm by sliding the forearm assembly forward until the bolt assembly clears the receiver.
4. The bolt is exposed and available to lift off the slide assembly. The bolt must be aligned with the bolt retainer pin. Slide the bolt forward and rearward while lifting up to detach the bolt from the slide (refer Fig. 5)

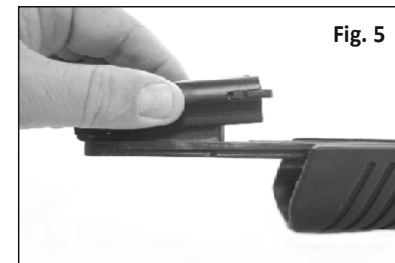

Fig. 5

! --Disassembly of Trigger Assembly From Receiver-- !

-wear safety glasses-

CAUTION: The hammer must be in the cocked position prior to removing the trigger assembly from the receiver. This should have been achieved by pulling the forearm to the rear prior to removal of the slide forearm assembly from the receiver. Do not pull the trigger while the trigger assembly is outside of the receiver.

1. Unload the Shotgun (refer to --Unloading The Shotgun--) and disassemble the barrel from the receiver (refer to --Disassembly Of Barrel From Receiver--)
2. Move the manual safety button to the "SAFE" position
3. Pull forearm to rear then forward to make sure the hammer is cocked.
4. With a hammer and punch push the trigger frame pins through the receiver (refer to Fig. 6) until the pins are out far enough to be grasped by hand, and remove the pin from the receiver Pull the trigger assembly slightly forward and then straight out from the receiver



Fig. 6

Use a pin and hammer to knock these pins out

--Removal Of Magazine Blocker--

-wear safety glasses-

1. Unscrew the magazine cap by turning it in a counter clock-wise direction until easily detached (refer to Fig. 4)
2. Pull the magazine blocker completely out of the hole in the end of the magazine tube (refer to Fig. 7)
3. Screw the magazine cap onto the end of the magazine tube until tight

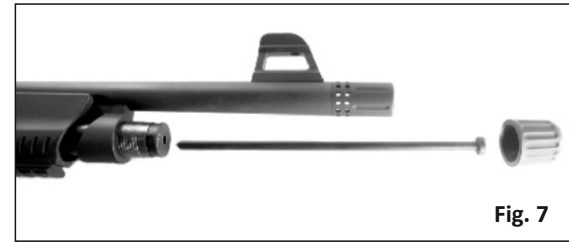

Fig. 7

! Cleaning Your Shotgun !

Preferably clean only in open air or at the very least extremely well ventilated area. You must take precautions to protect yourself from lead and solvent residue

**** Extremely limit use of solvents ****

Any firearm requires regular cleaning and periodic maintenance. To assure safe and reliable functioning of your Pump Action Shotgun, it is very important that you clean it immediately after each use, and periodically during extended storage periods, to remove powder residue, dirt, dust and excess lubricant, and prevent rust. During cleaning, inspect components to determine whether they are in proper working order. To properly clean your shotgun,

- It must first be disassembled (refer to --Disassembly Instructions--)
- The parts and components must be cleaned as discussed below
- Then reassembled (refer to --Assembly Instructions--)

-must wear safety glasses and solvent resistant gloves-

Apply solvents and lubricants properly and sparingly. Do not spray or apply solvents or lubricants directly on ammunitions. Solvents and lubricants may affect the propellant, causing it not to ignite. This situation may result in damage to the shotgun, serious injury to the shooter and bystanders.

Preferably clean only in open air or at the very least extremely well ventilated area.

Extremley limit use of solvents. Usesafetyglasses and solvent resistant gloves

--Cleaning The Bore--

You must take precautions to protect yourself from lead and solvent residue

1. Dip cleaning brush of proper size into cleaning solvent that is attached to the cleaning rod.
2. Push the brush all the way through the barrel bore several times from the chamber end.
3. Insert the brush into the muzzle of the barrel only far enough to encounter the threads for the choke tube, and twist it several times.
4. With a clean patch inserted in the tip attached to the cleaning rod, push the rod all the way through the barrel bore from the chamber end until the cloth emerges from the muzzle. Remove the dirty patch. Repeat step 4 as many times as needed until bore is cleaned.
5. Using a clean patch or lint-free cloth wrapped around the tip of your finger or similarly shaped object, remove all solvent from the muzzle and from the choke tube threads inside the barrel bore.
6. Insert a patch saturated with gun lubricant into the cleaning rod tip and push it through the bore from the chamber end. Remove the patch and withdraw the rod.
7. Insert a dry, clean patch into the cleaning rod tip and push it through the bore from the chamber end, to remove excess lubricant. Remove the patch and withdraw the rod.
8. Using a clean patch or lint-free cloth wrapped around the tip of your finger or similarly shaped object, apply a light coat of gun lubricant to the choke tube threads and muzzle of the barrel bore.

Excess lubrication in the bore or chamber of any firearm may create excessive chamber pressures or a partial bore obstruction, resulting in possible damage to the firearm and serious injury to the shooter and bystanders upon firing. BE SURE ALL EXCESS LUBRICANT HAS BEEN REMOVED.

--Cleaning The Outside Of The Barrel--

You must take precautions to protect yourself from lead and solvent residue.

1. Using a patch or clean cloth saturated with cleaning with proper oil, wipe down all accessible surfaces of the barrel, rib and barrel ring. (A clean tooth brush may be handy for cleaning the corners and recesses of the rib and barrel ring)

2. With a clean, dry, lint-free cloth, remove all excess oil. Using a patch or clean cloth, apply a light coat of gun lubricant to the outside surfaces of the barrel, rib and barrel ring, being careful to remove any excess lubricant.

--Cleaning The Choke Tubes / Muzzle Breaks--

1. Apply gun cleaning solvent to a bore cleaning brush of the proper size attached to the cleaning rod and push the brush all the way through the choke tube several times.
3. With a clean patch inserted in the tip attached to the cleaning rod, push the rod all the way through the choke tube until the patch emerges from the other end. Remove the dirty patch and withdraw the rod.
4. Repeat step 3 as many times as needed until the patch is clean as it emerges from the choke tube.
5. Insert a patch saturated with gun lubricant into the cleaning rod tip and push it through the choke tube. Remove the patch and withdraw the rod.
6. Insert a dry, clean patch into the cleaning rod tip and push it through the choke tube to remove excess lubricant. Remove the patch and withdraw the rod.
7. Using a patch or clean cloth saturated with cleaning solvent, wipe down the outside surfaces of the choke tube. (A clean tooth brush may be handy for cleaning the threads.)
8. With a clean, dry lint-free cloth, remove all cleaning solvent.
9. Using a patch or clean cloth, apply a light coat of gun lubricant to the outside surfaces of the choke tube, being careful to remove any excess lubricant.

--Cleaning The Receiver--

1. Using a small lint-free cloth, clean the inside and outside of the receiver with gun-cleaning solvent and dry thoroughly with a clean cloth.
2. With a clean cloth or patch, apply a light coat of gun lubricant to all accessible surfaces of the receiver.

--Cleaning The Bolt--

You must take precautions to protect yourself from lead and solvent residue

1. Using a small lint-free cloth, clean the inside and outside of the bolt assembly with gun-cleaning solvent; and dry thoroughly with a clean cloth. (A clean toothbrush may be handy for cleaning the recesses of the bolt)
2. With a clean cloth or patch, apply a light coat of gun lubricant to all accessible surfaces of the bolt.

--Cleaning The Slide And Forearm Assembly--

1. Using a small lint-free cloth, clean the inside and outside of the bolt assembly with gun-cleaning solvent; and dry thoroughly with a clean cloth. (A clean toothbrush may be handy for cleaning the recesses of the slide and forearm assembly)
2. With a clean cloth or patch, apply a light coat of gun lubricant to all accessible surfaces of the slide and forearm assembly.

--Cleaning The Magazine--

1. Using a lint-free cloth, clean the outside of the magazine tube with gun-cleaning solvent; and dry thoroughly with a clean cloth.
2. With a clean cloth or patch, apply a light coat of gun lubricant to outside surface of the magazine tube.

--Cleaning The Trigger Assembly--

CAUTION: The hammer must be in the cocked position prior to removing the trigger assembly from the receiver. This should have been achieved by pulling the forearm to the rear prior to removal of the slide forearm assembly from the receiver. Do not pull the trigger while the trigger assembly is outside of the receiver.

1. Using a small lint-free cloth, clean the outside of the trigger assembly and with a clean tooth brush, brush the top surface of the trigger assembly mechanism with gun-cleaning solvent.
2. Dry all exposed parts and surfaces thoroughly with a clean cloth.

--Cleaning The Forearm and Butt Stock--

Usually, wiping the forearm and butt stock with a clean, dry cloth or a silicon cloth is all that is necessary. If you have been hunting or shooting in wet weather, allow the butt stock and forearm to dry thoroughly before storage.

--Rust Prevention And Removal--

During normal maintenance, after a thorough cleaning, allow 2-3 hours at room temperature for all metal parts to dry completely. Then apply a liberal amount of high grade Gun Oil to all metal parts, wiping off any excess with a clean cloth. If rusting does occur it may only be surface rust due to excess moisture. You may be able to remove it by using a plastic bristle gun cleaning brush and gun cleaning solvent.

▲ Assembly Instructions ▲ -wear safety glasses-

--Assembly Of Trigger Assembly To Receiver--

1. Push the trigger assembly into the receiver until the trigger assembly is flush with the bottom of the receiver.
2. Push the trigger assembly rearward to seat the trigger assembly against the receiver, aligning the trigger pin hole in the trigger assembly with the corresponding trigger pin hole in the receiver.
3. Press the trigger frame pin into the receiver until flush with the side of the receiver.

--Assembly Of Bolt To Receiver--

1. Assemble the bolt assembly onto the slide and forearm assembly.
2. Place the tube of the slide and forearm assembly over the magazine tube and move the slide toward the receiver, aligning the bolt with the receiver as the bolt enters the receiver opening.
3. Slide the bolt into the receiver.

--Assembly Of Barrel To Receiver--

1. Visually examine the barrel to make sure there is no shot shell in the chamber or obstruction in the bore, and all surfaces are free of dirt and excess oil.
2. Move the forearm forward until the bolt protrudes slightly from the front of the receiver, (refer to Fig. 8)
3. Grasp the receiver and buttstock assembly with one hand, while grasping the barrel with your other hand.
4. Align the barrel shank on chamber end of the barrel with the bolt (refer to Fig. 9) and the barrel support ring with the magazine tube.
5. The bolt must be in the forward position on the slide to allow the locking block to retract.
6. Insert the barrel shank into the receiver until the barrel stops against the receiver.
7. With the barrel fully seated, place the magazine cap on the magazine tube and turn clockwise until seated.

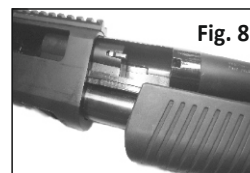

WARNINGS CONTINUED

WARNING!

BARRELOBSTRUCTION: BEFORE LOADING or firing a shotgun, examine the bore and the firing chamber to be certain they are clean and free of any obstruction. Even a heavy coat of oil, grease, snow or water may result in damage to the firearm and injury to the shooter and/or persons near the firearm. A misfire or unusual sound upon firing is a signal to cease firing and to examine the chamber and bore. If there is any obstruction, clear the obstruction and clean the bore and chamber before firing.



BARREL OBSTRUCTION: WARNING!

Any bore obstruction, even if it is only partly blocked, may cause the gun to blow up if it is fired, or may cause damage to the gun such as a bulged barrel. To avoid injury or death to the shooter or bystanders, check the barrel before shooting or if a shot does not sound normal.

WARNING! LIMITED VIEW:

Always keep the muzzle pointed in a safe direction! Never attempt to load or unload any firearm inside a vehicle, building or other confined space (except a properly constructed shooting range). Enclosed areas offer no completely safe direction in which to point the firearm because you don't know what is behind. If an accidental discharge occurs, there is great risk of injury, death, or property damage. Before loading, always clean all, grease and oil from the bore and chamber, and check to be certain that no obstruction is in the barrel. Any foreign matter in the barrel could result in a bulged or burst barrel or other damage to the firearm and could cause serious injury to the shooter or to others. When hunting in the fields or woods constantly monitor where everybody is. Properly position yourselves, don't let other shooters get even a few feet in front of you that they may be swinging on a target creating a deadly situation. Be aware of shooting at water or rocks due to ricochets.

WARNINGS CONTINUED

 **WARNING! BARREL** 

If there is any reason to suspect that a bullet or projectile is obstructing the barrel, immediately unload the firearm (See Unloading Instructions) and check the chamber and the bore. A bullet may be lodged some distance down the barrel where it can not easily be seen. Check the bore by using a cleaning rod to pass through the barrel. If a blockage is in the bore, **DO NOT ATTEMPT TO SHOOT IT OUT WITH ANOTHER CARTRIDGE, OR BLOW IT OUT WITH A BLANK CARTRIDGE OR A CARTRIDGE FROM WHICH THE BULLET HAS BEEN REMOVED. SUCH TECHNIQUE(S) CAN GENERATE EXCESSIVE PRESSURE, DAMAGE THE FIREARM AND CAUSE SERIOUS PERSONAL INJURY.** If the blockage can be removed with a cleaning rod, clean any unburned powder grains from the bore, chambers & mechanism before resuming shooting. If the blockage can not be dislodged by tapping it with a cleaning rod, take the firearm to a gunsmith.

 **WARNING! USE PROPER CHOKES:** 

Choose proper choke type, some chokes are rated for steel or lead. Other chokes are rated for lead only. Shooting steel down your chrome bore through a lead only choke will lead to serious damage of your firearm. It is easy to check, the choke tubes will have written on them what they are rated for. This applies for the models with the interchangeable choke tube function.

 **WARNING! LEAD EXPOSURE:** 

The actual firearm does not contain any lead, however it can fire ammunition containing lead, or lead compounds, known to the state of California to cause cancer, birth defects, reproductive harm, and other serious injury. Those who discharge a firearm stand near someone who fires or cleans firearms are hereby warned of the dangers presented by lead or lead compounds. Take protective health measures, avoid indoor shooting ranges. Clean firearms outdoors. Wear gloves, wash hands, etc.

⚠️ WARNINGS ⚠️

WARNING! POINT IN SAFE DIRECTION, ALWAYS ALWAYS POINT YOUR FIREARM IN A SAFE DIRECTION, EVEN WHEN CERTAIN FIREARM IS UNLOADED. THIS PRACTICE WILL SERVE YOU WELL WHEN IN THE EXCITEMENT OF THE HUNT. Think ahead. Example:
Don't lean loaded gun against yourself. As you pick up bird your dog may hit trigger.

⚠️ WARNING! NO SHOOTING FROM BOATS: ⚠️

Do not shoot from a boat. Do not shoot from a canoe, standing or sitting. Because the recoil will make the canoe/boat turn over, dropping you into the water. This may cause drowning or hypothermia, which also may lead to death.

⚠️ WARNING! LIGHTNING STORMS: ⚠️

Do not hunt, shoot, or stand in a lightning storm. Being struck by lightning will cause death or serious injury.

⚠️ FIRING WARNING! EYE AND EAR ⚠️

When shooting, full eye and ear protection is mandatory at all times. Shooters and spectators must wear shooting glasses and sound suppressor to prevent eye injury and hearing loss. Vision loss and hearing impairment can occur with only one moment of non-protection.

**⚠️ WARNINGS CONTINUED ⚠️
WARNING!**

Mechanical Malfunctions: STOP SHOOTING IMMEDIATELY AND UNLOAD YOUR FIREARM if your firearm develops: a mechanical malfunction; binding or stoppage; spitting powder/gas; cartridge primer is punctured; a cartridge case is bulged or ruptured; or the sound on firing does not sound quite right. Do NOT try one more shot but unload your firearm and take it and the ammunition to a qualified gunsmith or send it back to importer for examination. Do not assume that the shotgun is empty merely because you checked the chamber. You must also check the bore for any fired shot or wad jammed inside the barrel. Check for any kind of obstruction, including mouse nests, dead mouse, or spider webs, ice, snow, or mud.

WARNING! Hang Fire / Possible Delayed Discharge:
IF GUN FAILS TO FIRE, AS ALWAYS WATCH WHERE YOUR MUZZLE IS POINTING, WAIT FOR POSSIBLE DELAYED DISCHARGE FOR 5 MINUTES. SOMETIMES SLOW PRIMER IGNITION WILL CAUSE A "HANG-FIRE" AND THE CARTRIDGE WILL GO OFF AFTER A SHORT PAUSE. IF IT STILL FAILS TO FIRE, AGAIN, KEEP MUZZLE POINTED IN SAFE DIRECTION AT ALL TIMES, AVOID EXPOSURE TO THE BREECH. KEEP YOUR FACE AWAY FROM THE BREECH, THEN CAREFULLY OPEN ACTION, UNLOAD CARTRIDGE IN THOUGHTFUL SAFE WAY. DISPOSE OF CARTRIDGE IN THOUGHTFUL SAFE WAY.

ADDITIONAL VIEWS



Always use safety equipment while shooting!



EMPTY CHAMBER



LOADED CHAMBER

External Mag Tube Spring For Auto Bolt Return

-Must wear safety glasses-

Auto bolt return action spring location



Auto bolt return action spring

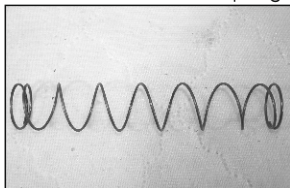

1. End of mag. Tube is where to slide auto bolt return spring on to.

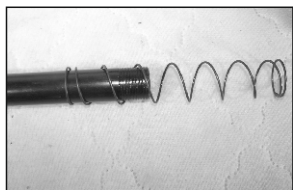

- 2. Push spring all the way down, then reassemble as done on pages 16-17.**
- 3. For cleaning you must disassemble the shotgun, see pages 8-15.**

LEGAL NOTICE

SHOTGUNS ARE CLASSIFIED AS FIREARMS OR DANGEROUS WEAPONS, are sold by Emperor Firearms and the importer SARAC with the specific understanding that we are not responsible in any manner what-so-ever for their safe handling or resale under local laws and regulations. Emperor Firearms and **importer** shall not be responsible in any manner whatsoever for the malfunctioning of the firearm, for physical injury or death, or for property damage resulting in whole or in part from (1) intentional or negligent discharge, (2) improper or careless handling, (3) unauthorized modifications and/or alteration to the internal/safety mechanisms, barrel, or other parts, (4) defective, improper, high pressure, hand-loaded, reloaded ammunition, **nonstandard**, damaged, or old ammunition, (5) abuse of firearm or lack of proper maintenance, corrosion, or lack of inspection by competent qualified gunsmith (6) neglect, or (7) other influences beyond our direct and immediate control. This limitation applies regardless of whether liability is asserted on the basis of contract, negligence or strict liability (including any failure to warn). Under no circumstances shall **Emperor** Firearms and importer be liable for incidental or consequential damages, such as loss of use of property, commercial loss and loss of earnings or profits.

WARRANTY REGISTRATION FORM

1 YEAR FREE WARRANTY FOR ORIGINAL PURCHASER

NAME : _____

LASTNAME : _____

STREET : _____

CITY : _____

STATE : _____

ZIP : _____

PHONE : _____

EMAIL : _____

PURCHASE DATE : _____

PRODUCT MODEL : _____

GAUGE OR CALIBER : _____

SERIAL NUMBER : _____

Please keep the purchase receipt for future service requests and proof of the purchase.

You Can email or fax this form to:
matt@saracfl.com or Fax : 347 892 3428
You can complete this form online via using our website
www.emperorfirearms.com

LIMITED WARRANTY **EMPEROR** FIREARMS – SARAC DISTRIBUTORS LLC ONE YEAR LIMITED WARRANTY AGAINST DEFECTS IN MATERIAL & WORKMANSHIP

This firearm warranty is good only to the ORIGINAL OWNER who has registered his ownership with SARAC DISTRIBUTORS LLC at 6391 Corporate Park Cir Ste 1, Fort Myers, FL 33966 and WARRANTY REGISTRATION FORM must be completed and mailed to SARAC DISTRIBUTORS LLC at the above address

WITHIN TEN (10) DAYS of purchase to insure the protection of the warranty.

NOTICE of defect in materials and/or workmanship must be received by the company WITHIN ONE (1) YEARS from the date of purchase. Normal wear, or damage resulting from neglect, abuse, alteration, or repairs not made or authorized by SARAC DISTRIBUTORS LLC or use of non-PTP 12 parts are not covered by the warranty. THIS WARRANTY GIVES YOU SPECIFIC LEGAL RIGHTS, AND YOU MAY ALSO HAVE OTHER RIGHTS WHICH VARY FROM STATE TO STATE.

SARAC DISTRIBUTOR LLC'S PERFORMANCE UNDER THE ABOVE WARRANTY

1. After notice of defect in material and/or workmanship is received by SARAC DIST.LLC, SARAC shall send instructions for shipment of the firearm; and repairs will be made and the firearm returned within a reasonable time after the firearm is received. Cost of shipping, insurance charges, etc. involved in returning the firearm to the company shall be prepaid by the original owner.

2. Cost of parts and labor performed shall be provided without charge by SARAC DISTRIBUTORS LLC.

3. If SARAC DISTRIBUTORS LLC, after receipt of the firearm, determines that the defects in material and/or workmanship were the result of abuse and/or neglect, or otherwise not covered by the warranty set forth above, SARAC shall notify such owner to that effect and give an estimate for repair. In such cases, repair, return shipping and insurance charges, etc. shall be paid by such owner.

4. In the event that SARAC DIST.LLC is unable to make warranty repairs to the firearm, it shall, within a reasonable time after its receipt, notify the owner to that effect and give him the option either to receive a replacement of the same model, if then available in its inventory, or to receive a refund, either of which, if feasible, will be made through the store of purchase.

What to do if Your Shotgun Fails to Fire

1. Underpowered Shot. A "squib" or underpowered shot should not occur if the ammunition is clean, dry and factory-loaded. You can tell if a shot is underpowered by the unusually low report it makes.







WARNING: Because wads, shot protector or lead may still be in the barrel, you must unload completely and, with the action open, and the safety on SAFE, look through the barrel to see if there is any obstruction. If there is, it must be removed before shooting the gun again.

2. Misfire. If you squeeze the trigger and the shell does not fire, remain in shooting position and count to 10. Then operate the action to eject the misfired shell.

ADDITIONAL INFORMATION

USAGE OF CHOKE TUBES

The choke is what controls the openness or tightness of the pattern of your shotgun. The chart below lists the choke available (from open to tight), and the corresponding marks that indicate the choke of your specific shotgun.

	SKEET	IC	M	IM	F	XF
CHOKE TUBE						
BBLS	CL	****	***	**	*	XF

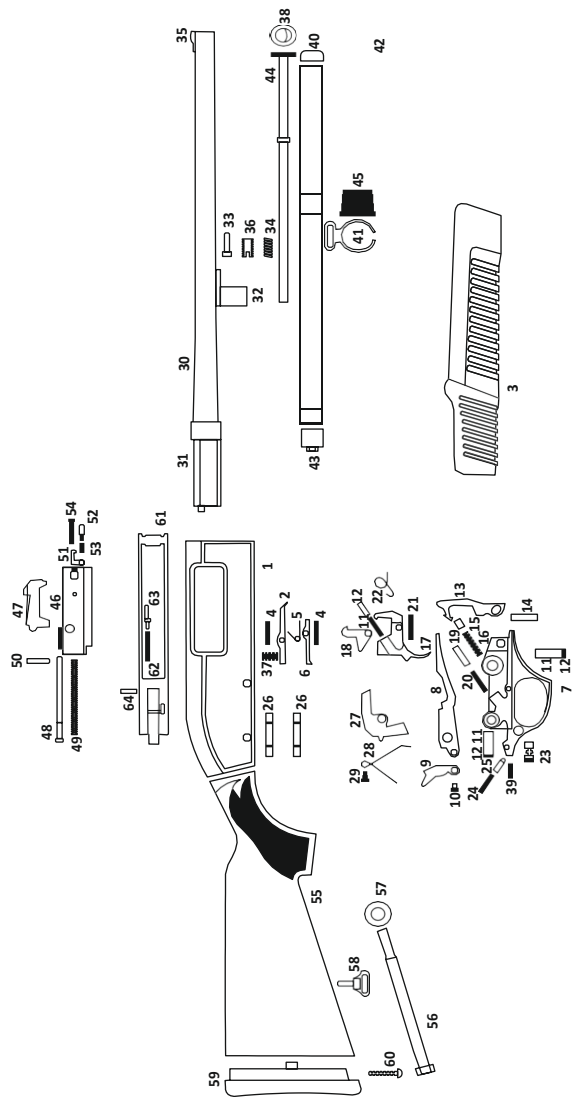

PART NO	DESCRIPTION	PART NO	DESCRIPTION
1	RECEIVER	33	PUMP RING PIN
2	CARRIER LATCH	34	PUMP RING SPRING
3	FORE-END	35	BEAD
4	CARRIER LATCH PIN	36	PUMP RING SCREW
5	CARTRIDGE HOLDER SPRING	37	METAL HOLDER SPRING
6	CARTRIDGE HOLDER	38	PLUG CAP
7	TRIGGER GROUP	39	SAFETY PIN
8	CARTRIDGE CARRIER	40	MAGAZINE UPPER CAP
9	CARTRIDGE LIFTER	41	SLING SWIVEL
10	CARTRIDGE LIFTER PIN	42	MAGAZINE SPRING
11	INTERNAL SAFETY SPRING	43	CARTRIDGE EJECTOR PLUG
12	INTERNAL SAFETY SPRING CASE	44	PLUG
13	HAMMER	45	MAGAZINE BOLT CAP
14	HAMMER PIN	46	BOLT ACTION
15	HAMMER PIN CAPSULE	47	LOCKING BLOCK
16	HAMMER SPRING	48	FIRING PIN
17	TRIGGER	49	FIRING PIN SPRING
18	INTERNAL SAFETY	50	FIRING PIN HOLDER
19	INTERNAL SAFETY CAPSULE	51	EXTRACTOR
20	INTERNAL SAFETY SPRING	52	EXTRACTOR PIN
21	TRIGGER PIN	53	EXTRACTOR SPRING
22	TRIGGER SPRING	54	EXTRACTOR SPRING PIN
23	SAFETY	55	GRIP
24	SAFETY SPRING	56	HEAT SHIELD
25	SAFETY CAPSULE	57	HEAT SHIELD SCREW
26	CAPSULE PIN	58	SLING SWIVEL
27	UNLOADING LATCH	59	GRIP KEY
28	UNLOADING LATCH SPRING	60	GRIP SCREW
29	UNLOADING LATCH SPRING SCREW	61	SLIDING BAR
30	BARREL	62	SLIDING BAR SPRING
31	BARREL LUG	63	SLIDING BAR PIN
32	PUMP RING	64	SLIDING BAR RIVETING PIN

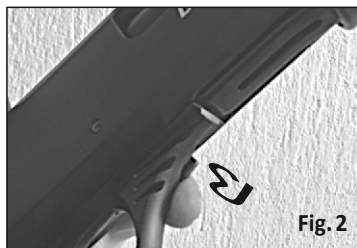

LOADING WITH CARTRIDGES

Release the loading port and push cartridges into the magazine tube. Repeat until magazine tube is full. (Figure 1)

PLACING THE CARTRIDGE ON THE CARRIER

After placing the cartridges on to the carrier, press the release latch. (Figure 2)



COCKING THE GUN

Pull the fore-end towards yourself to move the cartridge into the barrel and cock your shotgun. (Figure 3)

DISSEMBLING THE SHOTGUN

To remove the fore-end turn the magazine cap part counter-clockwise and remove the part. (Figure 4)

PLEASE READ THE **PREVIOUS** PAGES OF THIS MANUAL TO MAKE SURE THAT YOU COMPLETELY UNDERSTOOD HOW TO OPERATE THIS FIREARM. THIS IS AN ADDITIONAL INFORMATION TO SHOW VISUALLY HOW IT LOOKS LIKE TO **ASSEMBLE** OR DISMANTLE THE FIREARM.



Remove the pump action fore-end upside parallel to the barrel. (Figure 5)

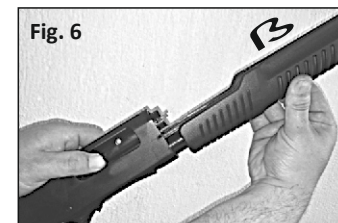

Remove the fore-end by holding the back the bolt action. (Figure 6)



Remove the pins on the receiver and remove the cover by pulling it down (Figure 7)

REMOVING THE CHOKE

Put the choke removing tool on the choke holes and turn the tool **towards** counter clockwise. (Figure 1). Turn the choke without the tool with your fingers counter clockwise until the choke is removed from the barrel. (Figure 2)

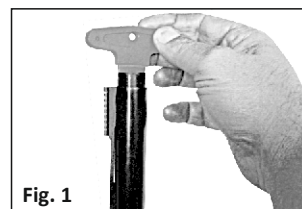

(Note: To install the choke, turn the choke clockwise direction).

PLEASE READ THE **PREVIOUS** PAGES OF THIS MANUAL TO MAKE SURE THAT YOU COMPLETELY UNDERSTOOD HOW TO OPERATE THIS FIREARM. THIS IS AN ADDITIONAL INFORMATION TO SHOW VISUALLY HOW IT LOOKS LIKE TO **ASSEMBLE** OR DISMANTLE THE FIREARM.