

# USER MANUAL

## Girsan Pistols



- **Compact MC** (9 x19 Single/Double Action)
- **MC39** (9 x19 Single/Double Action)
- **Regard MC** (9 x19 Single/Double Action)



**Come shoot the quality.**

Zenith Firearms, an American importer of high quality firearms and accessories, is a proud distributor of GIRSAN firearms. GIRSAN is the producer of Yavuz 16 pistols which are used by Turkey's foremost civilian and official establishments.



**WARNING**

Please read this user manual carefully before using the firearm.

**WARNING**

Do not use this firearm until you fully understand all of the safety instructions and handling procedures.

**NOTE**

Should you require further information, please call a Zenith Firearms representative at 434.202.7790.



## INDEX

1. GENERAL WARNINGS .....	4
2. SAFETY GUIDELINES .....	4
3. PRODUCT PRESENTATION AND SPECIFICATIONS .....	8
4. MAIN COMPONENTS .....	9
5. TECHNICAL SPECIFICATIONS.....	10
6. OPERATING SYSTEM.....	11
7. HOW TO USE THE PISTOL.....	12
8. MAINTENANCE AND CLEANING.....	17
9. REVERSING THE MAGAZINE RELEASE .....	21
10. TROUBLESHOOTING.....	22
11. EXPLODED DRAWINGS AND PART LIST .....	23
12. WARRANTY CERTIFICATE .....	26

## 1. GENERAL WARNINGS

- Read this user manual carefully before using the product.
- Do not use any firearm before reading the safety rules and maintenance instructions.
- Obey the laws in your country referring to firearms purchasing, carrying and use.

All firearms are dangerous. Zenith Firearms and GİRSAN are not responsible for any damage that results from the improper use of your firearm.

## 2. ESSENTIAL FIREARM SAFETY GUIDELINES

These firearm safety guidelines have been prepared by Zenith Firearms, based upon currently available information. They are provided to you as a courtesy and in the interest of furthering safety. These guidelines are not comprehensive, nor do they modify or replace rules, recommendations, standards, or regulations made by legal authorities or manufacturers.

As a responsible firearms supplier, Zenith believes that no issue is more important than firearm safety. We urge you to learn and practice the following guidelines and to make them your habit when handling firearms. This will help ensure safe handling of your firearm(s) and help prevent accidents. We also encourage you to complete an approved firearms safety-training course.

## THE 3 CARDINAL FIREARMS SAFETY RULES

### **1. Always handle a firearm as if it is loaded**

Even if you determine that a firearm is unloaded, always, always, always handle it like it IS loaded. When you handle a firearm, the first thing you should do (with the firearm pointed in a safe direction), is open the action to identify whether the firearm is loaded. If you do not know how to open the action, do not handle the firearm. And remember, removing a magazine alone does not make a firearm unloaded, as there may be a round in the chamber.

### **2. Always keep your finger out of the trigger guard and off the trigger until you are ready to shoot your target**

Do not place your finger inside the trigger guard until you have placed a firearm's sights on your target and have decided to fire. The best place to rest your finger in the meantime is above the trigger guard along the frame. By waiting until you are aimed at your target, if the trigger were to be pressed, you will guarantee that a shot will travel safely in the direction of your intended target.

### **3. Always keep a firearm pointed in a safe direction, before and beyond your target**

It is important to identify your actual target, but it is just as important to know what lies past and before your target. A safe direction is any direction where an unintentional discharge or miss will not cause injury or damage. In determining a safe direction, remember that a round can ricochet off an object like a floor, water or wall, or go through walls, floors, ceilings, and windows. Whether in a house or outdoors, the safest direction is the muzzle angled down toward the floor. And never point at or cross the muzzle of a firearm (loaded or unloaded) at any part of any person's body—the laser rule!

## **ADDITIONAL FIREARMS AND AMMUNITION RULES**

### **ALWAYS KEEP CHILDREN AND OTHERS SAFE BY STORING FIREARMS SECURE AND AWAY FROM UNAUTHORIZED PERSONS**

You should always store firearms and ammunition out of the sight and reach of children and anyone else who is not an intended user or not physically or mentally capable of handling and using them properly and safely. Store firearms in a safe storage place – ideally, one you can lock.

### **CAREFULLY READ THE ENTIRE INSTRUCTION MANUAL THAT COMES WITH YOUR FIREARM**

You should only use a firearm if you fully understand how to safely operate it. All firearms come with an instruction manual created by the manufacturer. If the firearm does not come with an instruction manual, contact the manufacturer directly and request one.

### **ALWAYS DETERMINE THAT THE FIREARM IS SAFE TO OPERATE**

Before shooting, make sure the firearm is in good working order, that the barrel is clear, and that the firearm is safe to operate. This is especially important when handling a firearm that has been stored or unused for a long period of time.

### **ALWAYS USE CORRECT AMMUNITION**

Never use improper or incorrect ammunition. Only use ammunition that is recommended by the firearm manufacturer the caliber of your firearm. Most firearms have the caliber engraved or stamped on the barrel. Your ammunition should have the exact same caliber. If you use the incorrect ammunition, it can destroy a firearm and cause serious injury. Additionally, it voids your warranty.

**WHEN CLEANING A FIREARM, MAKE SURE IT IS NOT LOADED**

One of the most common statements following an accidental discharge is: “I was cleaning the firearm and it went off!” When you clean a firearm, make sure it is not loaded. You should keep the ammunition in another room until you have finished cleaning the firearm and are ready to reload.

**NEVER USE FIREARMS WHILE USING DRUGS OR ALCOHOL**

When you handle firearms, your judgment must NOT be impaired. You should NEVER handle firearms while under the influence of alcohol, illegal drugs or while using legal prescription medication that can make you tired or affect your senses, reflexes, or judgment.

**USE EYE AND EAR PROTECTION**

Always wear proper eye and ear protection while shooting firearms; ear protection will help prevent hearing loss from the extreme decibel level of gunfire, and eye protection will help prevent ejection gases, ricocheted objects, casings, or any foreign objects from damaging your eyes. Be smart, be safe.

### 3. PRODUCT PRESENTATION AND SPECIFICATIONS

Your pistol comes with the accessories listed below:

- Pistol
- 3 magazines
- User manual
- Cleaning and oiling supplies
- Pistol lock

#### **GENERAL SPECS OF THE PISTOL**

There are differences among the GİRSAN pistols, but this series all use a similar operating system.

**Locking System:** Most GİRSAN pistols are semi-automatic firearms operating on the short recoil principle. This action is provided by the slide moving to the rear and the barrel moving down once unlocked. The other system utilized is the recoil operated system where the barrel is fixed and the slide moves rearward once the barrel pressure drops.

**Loaded Chamber Indicator:** When a round is chambered, the extractor head protrudes further from the slide breech and exposes a red warning tab. In the dark, this protrusion can also be felt by touch. This makes it unnecessary to pull back the slide to verify if the chamber is loaded.



#### 4. MAIN COMPONENTS

- ① Slide
- ② Forged steel barrel
- ③ Barrel locking block plunger
- ④ Recoil spring guide
- ⑤ Recoil spring
- ⑥ Frame (grip and trigger group)



## 5. TECHNICAL SPECIFICATIONS

MODELS	REGARD MC	COMPACT MC	MC39
Caliber	9 mm x 19 Parabellum	9 mm x 19 Parabellum	9 mm x 19 Parabellum
Operating System	semi-automatic	semi-automatic	semi-automatic
Length	8.54 inches	7.89 inches	7.90 inches
Height	5.39 inches	5.39 inches	5.39 inches
Width	1.30 inches	1.30 inches	1.30 inches
Weight (without magazine)	30.8 ounces	29.3 ounces	27.5 ounces
Capacity	15 + 1	15 + 1	15 + 1
Full Magazine Weight	9.9 ounces	9.9 ounces	9.9 ounces
Barrel Length	4.92 inches	4.33 inches	4.33 inches
Barrel Production Method	cold forged steel	cold forged steel	cold forged steel
Barrel Life	30,000 rounds	30,000 rounds	30,000 rounds
Sight System	fixed sights (optional adjustable sight)	fixed sights (optional adjustable sight)	fixed sights (optional adjustable sight)
Sight Radius	6.10 inches	5.71 inches	5.71 inches
Safety System	safety lever, firing pin safety block, hammer safety, chamber loaded indicator	safety lever, firing pin safety block, hammer safety, chamber loaded indicator	safety lever, firing pin safety block, hammer safety, chamber loaded indicator
Effective Range	295 feet (± 33 feet)	262 feet (± 33 feet)	262 feet (± 33 feet)
Muzzle Velocity	1,191 FPS	1,191 FPS	1,191 FPS
Trigger System	single action/double action	single action/double action	single action/double action

## 6. OPERATING SYSTEM

GİRSAN pistols are semi-automatic firearms operating on the **short recoil** principle using a falling block locking system. Upon firing, the pressure developed by combustion gas in the chamber recoils the slide and barrel assembly together. After a short distance, the locking block falls and releases the slide, letting it recoil while the barrel stops against the frame. During this rearward movement, the slide extracts and ejects the fired cartridge case, cocks the hammer and compresses the recoil spring. Under the force of the recoil spring, the slide then moves forward, feeding the next cartridge from the magazine into the chamber and causing the barrel-slide to lock. The slide stays open after the last cartridge in the magazine has been fired and ejected.

In the **recoil operating system**, the slide never truly locks, but its mass holds it in place while firing. The energy of the round forces the slide to the rear. Once it is back, it operates the same as above.



### WARNING

Do not apply force to the pistol with any object while handling, cocking, disassembling or cleaning the pistol.

## 7. HOW TO USE THE PISTOL



### WARNING

Keep your finger outside the trigger guard and off the trigger until you intend to fire.

#### BEFORE SHOOTING

- With the safety on, the pistol cannot fire. Set the safety lever “on” (Picture 1) and in this position the red dot on the slide is completely hidden.
- Prior to use, be sure that the chamber is empty and the barrel is free from any obstructions (Picture 2).
- If you do not intend to fire the pistol, keep your fingers off the trigger. Always check the loaded chamber indicator (Picture 3) to see if it is loaded or unloaded (if applicable). If red is visible, the firearm is not safe.



#### FUNCTION CHECKS

- Be sure that the pistol is unloaded and the magazine is empty before starting any function checks (Pictures 2, 3, 4).

### SLIDE AND BODY FRAME CHECKS

- Release the magazine by pressing the magazine release button (Picture 5). Pull the slide all the way to the rear (Picture 6).
- While drawing the slide back, make sure the slide moves easily on the body frame and cocks the hammer.



Picture 5



Picture 6

- If the hammer is cocked when you retract the slide, pull the trigger and check to ensure the hammer decocks properly.
- After inserting an empty magazine, repeat the same action. The slide will stay locked and open in the rear position (Picture 7).



Picture 7



Picture 8

### TRIGGER AND SAFETY LEVER CONTROLS

- After cocking the hammer, pull the trigger to check if the hammer falls making an audible click (Picture 8).
- The safety lever also acts as a decocking lever. The safety/decocking lever drops the hammer safely, but blocks the hammer from striking the firing pin, and disconnects the link between the trigger and the sear.
- With the safety lever on, check if the above action occurs.

### **PREPARING TO SHOOT**

- Always point the pistol in a safe direction.
- Make sure that the pistol is in safe mode (if applicable).
- Make sure there is no obstruction in the barrel.
- Check if the pistol is operating properly.
- Ensure the magazine is fitting correctly.

### **LOADING THE MAGAZINE**

- Hold the magazine in an upright position.
- Push the cartridge downwards and to the rear of the magazine.
- Fully load the magazine.



### **WARNING**

You can check the number of cartridges in the magazine from the visible holes on the rear of the magazine. Loading more than magazine capacity can damage your magazine.

### **LOADING THE PISTOL**

- Point the pistol in a safe direction.
- Put the loaded magazine into the pistol and ensure the magazine release catches.
- Pull the slide back to the end and release it freely.
- Now the pistol is loaded and ready to fire. The chamber loaded indicator shows that the pistol is loaded.



## WARNING

Pistol is loaded and ready to be fired. Keep your finger out of the trigger guard and off the trigger until you intend to fire.

NOTE: GIRSAN pistols have a firing pin block safety, this system will not allow the firing pin to strike the primer on the cartridge unless the trigger is pulled.

## TARGETING

The sight alignment is created by arranging the front and rear sights on the same line. Ensure there is equal spacing on either side of the front sight when viewed through the rear sight and that the two sights are level.



## WARNING

After the first shot, the pistol is automatically loaded and the hammer is cocked, the pistol is ready to be fired again. If you do not intend to fire again, keep your finger off the trigger and set the safety/decocking lever on safe.

## SHOOTING IN SINGLE ACTION MODE

- Point the pistol at the target.
- Rotate the safety/decocking lever upward with your thumb.
- When you are ready to fire, cock the hammer (Picture 9) and pull the trigger to fire (Picture 10).
- Alternate method: With finger off trigger, use off hand thumb to cock hammer.



Picture 9



Picture 10



## WARNING

Do not utilize a grip that places your non-shooting hand in back of the slide. The slide's movement will cause injury and a malfunction.

### SHOOTING IN DOUBLE ACTION MODE

- Point the pistol at the target.
- Rotate the safety/decocking lever upward with your thumb. If the hammer is decocked (Picture 11), pulling the trigger completes the first action of cocking the hammer completely and the second action of letting the hammer drop and strike the firing pin. This is what is meant by a double action trigger system.
- After the first shot, the pistol fires sequential rounds in single action mode. The longer and heavy double action trigger pull is considered a safety feature because it also helps reduce the likelihood of an unintentional discharge.
- After the last round in the magazine is fired, the slide remains open and locked to the rear (Picture 12). To continue firing, remove the empty magazine and insert a loaded magazine.
- Press the slide release lever, or pull the slide to the rear and release the slide to load the chamber (Picture 13).



Picture 11



Picture 12



Picture 13



### **UNLOADING THE PISTOL**

- The pistol can still be loaded even when the magazine is removed.
- Point the barrel of the pistol in a safe direction.
- Press the magazine release button to take the magazine out.
- Pull the slide back to remove the cartridge from the chamber.
- Release the slide back to the front, after ensuring that the chamber is empty (visually and physically ensure there is not a cartridge in the chamber).

### **UNLOADING THE MAGAZINE**

- Push the cartridge forward until releasing from the magazine.
- Continue this until extracting all the cartridges from the magazine.



### **WARNING**

Use only original factory ammunition and make sure that the caliber of the ammunition and the pistol is the same. Use of reloaded ammunition voids warranty.

## **8. MAINTENANCE AND CLEANING**

- Make sure that the pistol is unloaded before starting maintenance.
- If the pistol is not unloaded, follow unloading instructions (see *Unloading the Pistol*, above).
- Cleaning the pistol should be done after every shooting. The cleaning kit provided with the pistol includes two cleaning brushes, one ramrod, and oil. It is appropriate to substitute other cleaning products in place of oil.

### DISASSEMBLY OF THE PISTOL

Make sure that the pistol is unloaded before disassembly of the pistol.

- Take the magazine out by pressing the magazine release button.
- Press the disassembly latch release button which protrudes from the right side of the pistol with the index finger (Picture 14).
- While you are pressing the button, rotate the disassembly latch on the left side of the frame with the thumb 90° clockwise (Picture 15). Move the slide forward with the barrel, locking block, recoil spring and recoil spring guide rod (Picture 16).
- While slightly pressing the recoil spring and spring guide, move forward, lift and take out the recoil spring and guide from the slide (Picture 17). Be careful, the recoil spring and guide are under tension. Press barrel locking block plunger and take out the barrel with locking block from the slide (Picture 18).



### CLEANING THE PISTOL

Cleaning and oiling the barrel:

- Spray a little gun oil on the brush.
- Insert the brush into the barrel from breach or chambered end (Picture 19).
- Brush the inside of the barrel by pushing forward and backwards.
- Wipe the inside of the barrel with a clean and dry patch until the patch comes out clean (Picture 20).
- Clean the barrel locking block with the brush sprayed with protective oil (Pictures 21 and 22). If necessary, you can apply oil lightly to the outside of the barrel by passing a clean cotton patch soaked in protective oil through it (Picture 23).

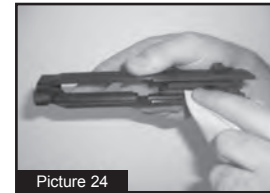
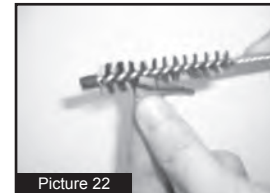

Cleaning the slide and oiling:

- Clean the slide with the oiled brush (Picture 24).
- Lightly oil the slide.
- A good method is to allow a drop of oil to flow down the slide rails by gravity (Picture 25).



*Note: Other firearms cleaners can be used in place of oil.*



## WARNING

Do not oil the firing pin hole while cleaning.

Clean and oil the recoil spring and recoil rod:

- Lightly oil the recoil spring and recoil rod (Picture 26).

Clean and oil the frame:

- Clean all surfaces carefully (Picture 27).
- Put a light coat of oil on the rails and trigger bar – sear connection (Picture 28).

Clean and oil the magazine:

- Make sure the magazine is empty.
- Pull the magazine butt-plate down and remove it utilizing the tool provided to unlock the floor plate.
- Remove debris inside the magazine with the brush.
- Clean the inside and outside of the magazine.
- Assemble the magazine by applying the reverse method of disassembly.

## ASSEMBLY OF THE PISTOL

- Put the barrel inside the slide.
- Put the recoil spring in the slide group and make sure the recoil rod is fitted to the barrel notch correctly.
- Put the slide group in the rails on the frame as shown.
- Push the slide back to the end and the take down lever will rotate counter clockwise, locking itself.



Picture 26

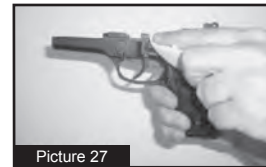

Picture 27



Picture 28

## 9. REVERSING THE MAGAZINE RELEASE

It is recommended that a gunsmith or armorer is used for this procedure.

Left handed shooters can change the magazine release to the right side by following the instructions below:

- Unscrew and remove the grips with a proper screwdriver (Picture 29). Press the back of the magazine release button down from the flat side (Picture 30). The magazine release button assembly will then drop out.
- Reverse the magazine release button assembly and insert the button of the grooved side into position, tilting it slightly. Holding the button from the grooved side of magazine, press its flat side and push it until it clicks into place (Picture 31). The operation is done correctly when the magazine slides easily into its housing. Replace the grips with screws. Do not overtighten.



Picture 29



Picture 30



Picture 31

## 10. TROUBLESHOOTING

PROBLEM	POSSIBLE REASON	SOLUTION
Misfire	Damaged cartridges	Replace cartridges
	Firing pin problem	Clean the firing pin
		Send it to the authorized service center
	The slide did not close correctly	Check for obstruction
Send it to the authorized service center		
Feeding problem	Magazine is not inserted correctly	Re-insert the magazine into the magazine well
	Faulty magazine	Exchange the magazine
	Dirty magazine	Clean the magazine
Ejection problem	Dirty chamber	Clean and oil lightly
	Ejection problem	Send it to the authorized service center
	Extraction problem	Send it to the authorized service center

## 11. EXPLODED DRAWINGS

(9x19 mm) YAVUZ16 COMPACT M.C. EXPLODED DRAWING

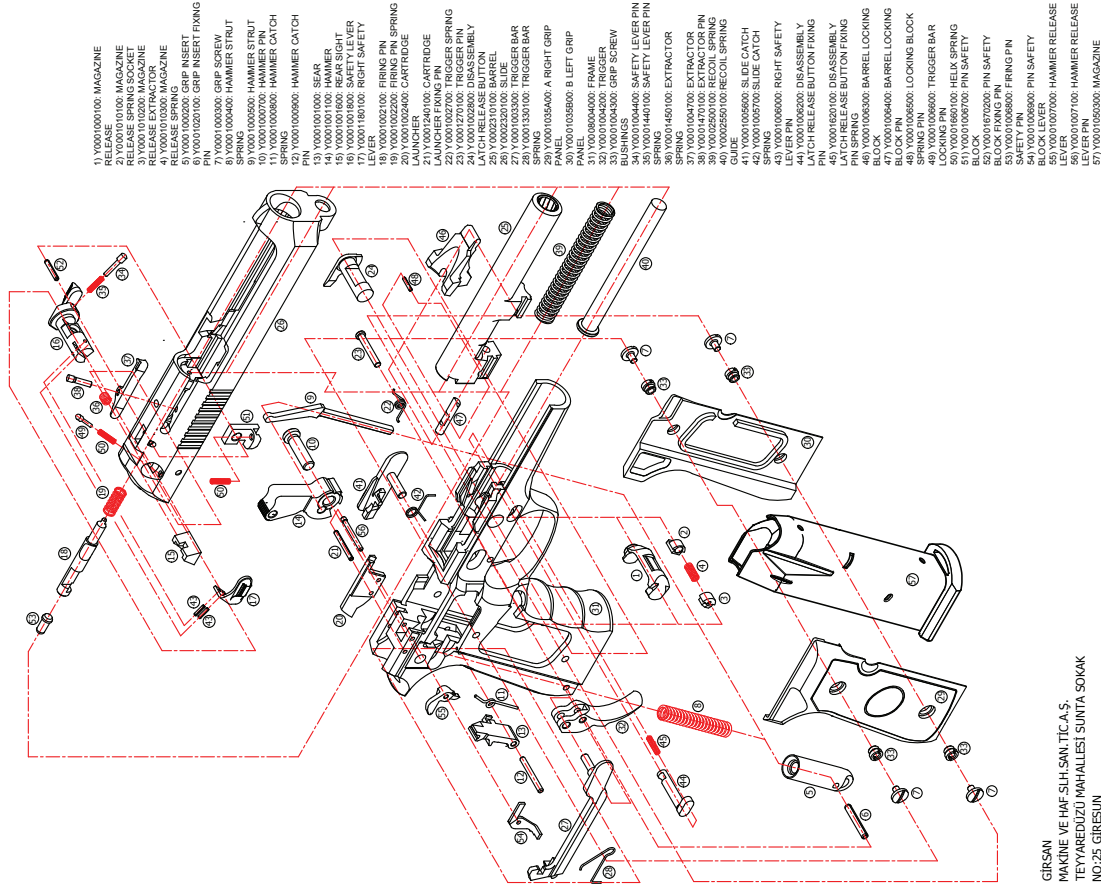

GIRSAN  
 MAKINE VE HAF S.H.SAN.TI.C.A.S.  
 TEYAREVEDUZI MAHALLESI SUNTA SOKAK  
 NO:25 GİRSEUN  
 TEL: 0454 215 39 35 - 0454 215 29 31  
 FAX: 0454 215 39 28  
 http://www.girsan.com  
 e-posta: girsan@girsan.com

**(9x19 mm) MC39 EXPLODED DRAWING**

**GIRSAN**  
 MAKİNE VE HAF. S.H.ŞAN.Tİ.C.A.Ş.  
 ÇİTLAKKALE MAH. BATILAMA DERESESİ MEYKİİ  
 GİRSESUN  
 TEL: 0454 215 39 35 - 0454 215 29 31  
 FAX: 0454 215 39 28  
 http://www.yevuz16.com  
 e-posta: yevuz16@yevuz16.com

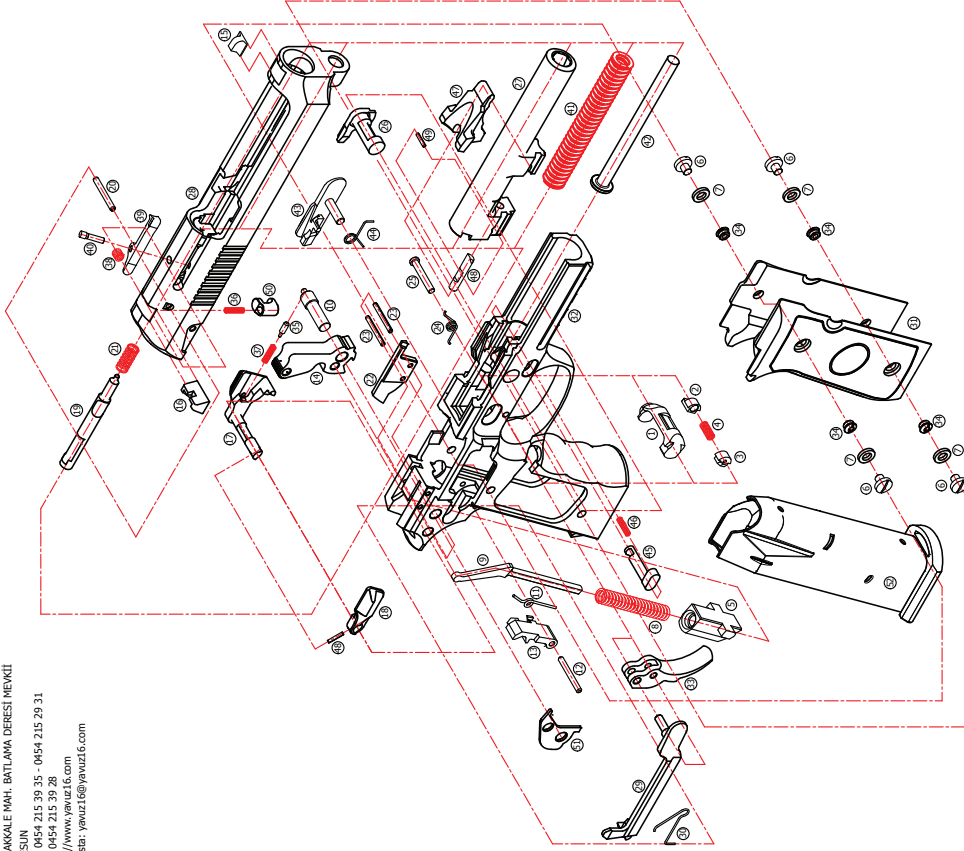

- |   |   |   |   |
|---|---|---|---|
| 1) Y000100000 MAGAZINE RELEASE            | 16) Y0001001500 REAR SIGHT                | 30) Y000130100 TRIGGER BAR SPRING       | 45) Y0001006200 DISASSEMBLY LATCH RELEASE |
| 2) Y000010100 MAGAZINE RELEASE SPRING     | 17) Y0001000000 TRIGGER                   | 31) Y0039003500 GRIP PANEL              | 46) Y0001020000 DISASSEMBLY LATCH RELEASE |
| 3) Y0000100000 MAGAZINE RELEASE SPRING    | 18) Y0039180500 SAFETY LEVER              | 32) Y0039003500 TRIGGER                 | 47) Y0001006500 BUTTON FRKING PIN SPRING  |
| 4) Y0001002000 MAGAZINE RELEASE EXTRACTOR | 19) Y0039002100 FIRING PIN EXTING P/FIN   | 33) Y0001004000 TRIGGER                 | 48) Y0001006500 BARREL LOCKING BLOCK      |
| 5) Y0001002000 MAGAZINE RELEASE SPRING    | 20) Y0013201000 FIRING PIN EXTING P/FIN   | 34) Y0039004000 GRIP SCREW BUSHINGS     | 49) Y0001006500 LOCKING BLOCK SPRING PIN  |
| 6) Y000000000 GRIP SCREW                  | 21) Y0001002400 CARTRIDGE LAUNCHER        | 35) Y0001004000 TRIGGER                 | 50) Y0039005700 PIN SAFETY BLOCK          |
| 7) Y00220020100 GRIP SCREW FRKING WASHER  | 22) Y0001240100 CARTRIDGE LAUNCHER EXTING | 36) Y0001004000 SAFETY LEVER PIN SPRING | 51) Y0039005700 PIN SAFETY BLOCK LETTER   |
| 8) Y0001000400 HAMMER SHOOT SPRING        | 23) Y0001240100 CARTRIDGE LAUNCHER EXTING | 37) Y001340100 SAFETY LEVER PIN SPRING  | 52) Y0001005000 MAGAZINE                  |
| 9) Y0001000400 HAMMER SHOOT SPRING        | 24) Y0001002700 TRIGGER SPRING            | 38) Y0001005000 EXTRACTOR SPRING        |   |
| 10) Y0022000700 HAMMER PIN                | 25) Y0001270100 TRIGGER PIN               | 39) Y0001005000 EXTRACTOR SPRING        |   |
| 11) Y0022000600 HAMMER CATCH SPRING       | 26) Y0001002600 DISASSEMBLY LATCH RELEASE | 40) Y0001007000 EXTRACTOR PIN           |   |
| 12) Y0022001000 SEAR                      | 27) Y0002310100 BARREL                    | 41) Y0039005000 RECOIL SPRING           |   |
| 13) Y0022001000 HAMMER                    | 28) Y0002310100 SLIDE                     | 42) Y0001005000 GUIDE                   |   |
| 14) Y0039001500 FORCE SIGHT               | 29) Y0039003500 TRIGGER BAR               | 43) Y0001005600 SLIDE CATCH SPRING      |   |
|   |   | 44) Y0001005700 SLIDE CATCH SPRING      |   |



(9x19 mm) YAVUZ16 REGARD M.C. EXPLODED DRAWING

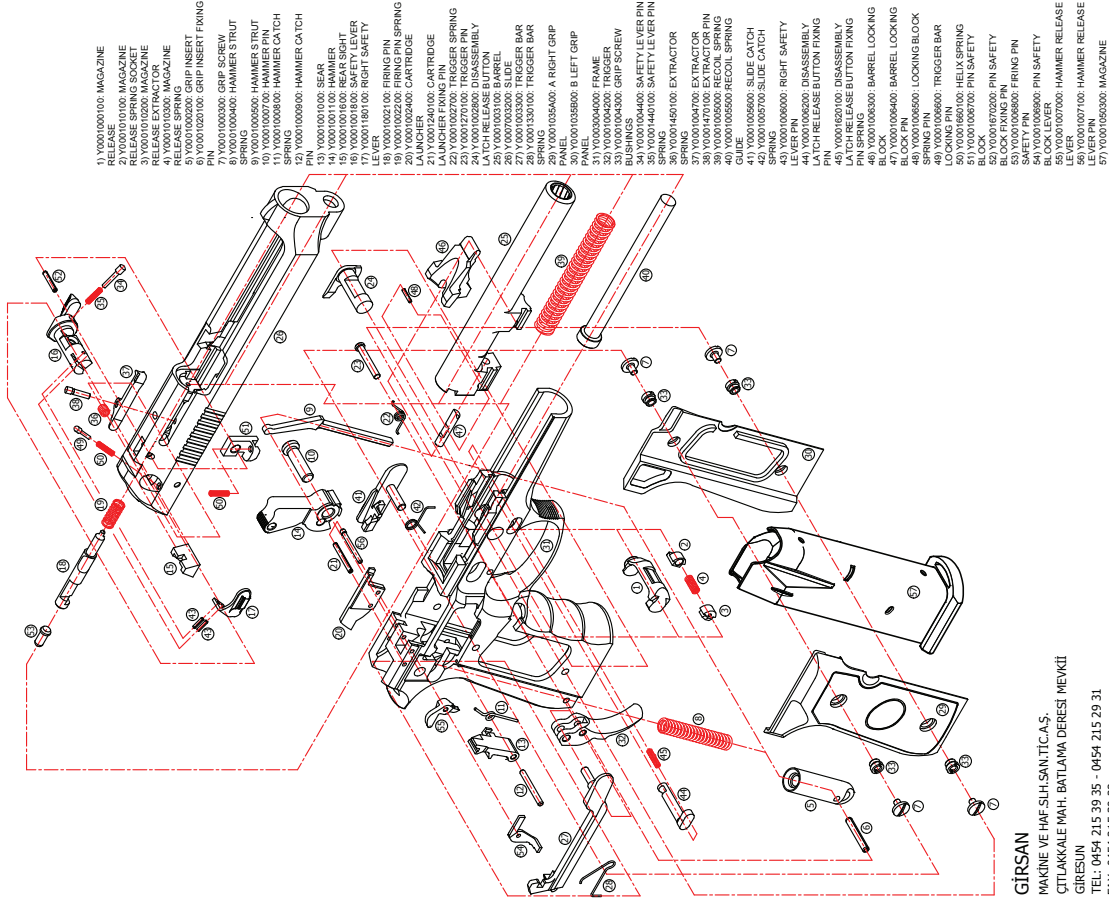

**GİRSAN**

MAKİNE VE HAF-SİH.SAN.Tİ.C.A.S.  
 ÇTLAKKALE MAH. BATILAMA DERESİ MEVKİİ  
 GİRSESUN  
 TEL: 0454 215 39 35 - 0454 215 29 31  
 FAX: 0454 215 29 28  
<http://www.yavuz16.com>  
 e-posta: yavuz16@yavuz16.com



## Zenith Firearms Warranty

At Zenith Firearms, we believe in the quality of our firearms, and we want you to as well.

Age and wear cannot be covered under warranty, as the mechanical parts and materials that make up firearms eventually wear out. However, defective parts, materials, and workmanship are not acceptable, and we will stand behind our products. We warrant our firearms to be free from defects in performance and workmanship for one year from the date of purchase. If you have a problem that is directly attributable to the quality of our product, it's on us to make it right, shipping and handling included.

However, if you abuse, improperly maintain, or alter the internal workings of your Zenith firearm in any way, we will not warranty damage that occurs. Likewise, if you use improper or incompatible ammunition or parts, we will not warranty damage that occurs. This includes altering a serial number.

If you have a problem with your firearm, please contact a customer service representative at 434-202-7790.

### RETURN WITHOUT REPAIR

If we receive your firearm and determine that its damage is unwarrantable, we will contact you with an explanation and an estimation of your cost to have us repair or refurbish it. If you would rather we simply return your firearm to you, we will cover the cost of shipping to do so.

### FREE REPAIR AND RETURN

If your firearm is defective and we determine the defect is warrantied, Zenith will try to repair it. If we repair your firearm, after doing so we will ship it directly back to you, provided you originally shipped it to us from your address. If your firearm cannot be repaired, we will consider replacing it. If we end up replacing your firearm, we will ship it back to you via a licensed FFL dealer, and there may be additional charges that you'll have to cover, such as transfer fees and background check fees. In either case, though, we will pay for shipping.

### LIMITATIONS ON WARRANTY

OUR ONLY RESPONSIBILITY IN THE CASE OF BREACH OF WARRANTY IS REPAIR. ZENITH FIREARMS SHALL NOT BE LIABLE FOR ANY OTHER DAMAGES, INCLUDING DIRECT, INDIRECT, OR CONSEQUENTIAL DAMAGES.

Please Note: This warranty gives you specific legal rights, and you may also have other rights, which vary from state to state, as some jurisdictions do not allow limitations on certain damages and warranties.

**NOTES:**

---

---

---

---

---

---

---

---

---

---

---

---

---

---

---

---

---

---

---

---

---

---

---

---

---

---

---

---



## Zenith Firearms

10950 Rockfish Valley Highway, Suite C, Afton, VA 22920

Tel: 434.202.7790 | Fax: 800.466.4444 | [info@zenithfirearms.com](mailto:info@zenithfirearms.com) | [www.zenithfirearms.com](http://www.zenithfirearms.com)