



**Z-SERIES**  
**RIFLE & PISTOL**  
5.56x45 mm

**USER MANUAL**

V.01



# INDEX

Z-43 SERIES PISTOL & RIFLE .....	3
Z-43 RIFLE .....	4
Z-43P PISTOL .....	5
ESSENTIAL FIREARM SAFETY GUIDELINES.....	6
Z-43 RIFLE MAJOR ASSEMBLY GROUPS .....	9
Receiver and Barrel Assembly .....	10
Bolt Carrier Assembly .....	10
Trigger Housing and Buttstock Assembly .....	11
Hand Guard .....	12
Recoil Spring .....	12
Magazine Assembly .....	12
Picatinny Rail.....	13
Z-43 RIFLE DISASSEMBLY PROCEDURES.....	14
Magazine Removal .....	14
Trigger Housing and Buttstock Removal .....	14
Recoil Spring and Bolt Carrier Removal .....	16
Hand Guard Removal .....	17
Z-43 RIFLE REASSEMBLY.....	17
Z-43P PISTOL MAJOR ASSEMBLY GROUPS .....	18
Receiver and Barrel Assembly.....	19
Bolt Carrier Assembly .....	19
Trigger Housing Assembly .....	20
Butt Cap .....	21
Hand Guard .....	21
Recoil Spring .....	21
Magazine Assembly .....	21
Picatinny Rail.....	22
Z-43P PISTOL DISASSEMBLY PROCEDURES.....	23
Magazine Removal .....	23
Butt Cap Removal .....	23
Recoil Spring and Bolt Carrier Removal .....	24
Trigger Housing Removal.....	24
Hand Guard Removal .....	25
Z-43P PISTOL REASSEMBLY.....	25
Z-43 SERIES RIFLE & PISTOL OPERATION .....	26
Selecting the Firearm to Safe .....	26
Selecting the Firearm to Semi-Auto Fire .....	26
Loading and Unloading the Magazine.....	27
Loading the Firearm.....	28
Firearm Operating System .....	30
Trigger Operating System .....	32
Z-43 RIFLE & Z-43P PISTOL SIGHTS .....	33
Using the Sights .....	33
Rear Sight Adjustment .....	34



FIREARM MAINTENANCE ..... 35

- Extreme Climate Maintenance ..... 35
- Disassembly and Maintenance of Bolt Carrier ..... 36
- Maintenance of Bolt Carrier Assembly ..... 37
- Trigger Pack Removal and Maintenance ..... 38

Z-43 SERIES RIFLE & PISTOL SLING ..... 39

- 3-Point Sling ..... 39

TROUBLESHOOTING ..... 40

# Z-43 SERIES PISTOL & RIFLE

Z-43 Series Rifles & Pistols have been manufactured by MKE Corporation for the US market.

Z-43 Series Rifles & Pistols:

- Are manufactured utilizing the latest production techniques and machinery.
- Utilizes the reliable roller-lock, delayed blowback operating system.
- Are manufactured with cold hammer forged chrome moly vanadium barrels.
- Carry their serial numbers on the upper portion of the receivers.
- Are chambered for the 5.56x45 mm cartridge.

## Available Models



Z-43 Rifle



Z-43P Pistol



# Z-43 RIFLE



Figure 1 - Z-43 Rifle

## Technical Specifications

Ammunition	5.56x45 mm NATO
Operation	Semi-automatic, magazine fed, air cooled, delayed blow back, roller-lock
Sights	Rear drum for elevation and windage, front protected post
Magazine	10-Round amber polycarbonate
OA Length	36.2 inches
Barrel Length	16.15 inches
Barrel Twist	1:7 inches
Barrel Lands/Grooves	6
Barrel	Cold hammer forged 32 chrome molybdenum vanadium
Fluted Chambers	18
Trigger	5.6-10 pounds
Colors	Black, green, camo
Weight Empty	8.9 pounds
Additional	Barrel has 15x1 RHM threaded end and pinned muzzle brake.
Includes	Rugged plastic carry case, three (3) 10-round magazines, factory cleaning kit, two (2) extra take-down pins, factory Picatinny style optics mount, factory sling, and 5-year warranty.

# Z-43P PISTOL



Figure 2- Z-43P Pistol

## Technical Specifications

Ammunition	5.56x45 mm NATO
Operation	Semi-automatic, magazine fed, air cooled, roller-lock, delayed blowback
Sights	Rear drum for elevation and windage, front protected post
Magazine	30-Round amber polycarbonate
OA Length	23.3 inches
Barrel Length	12.08 inches
Barrel Twist	1:7 inches
Barrel Lands/Grooves	6
Barrel	Cold hammer forged 32 chrome molybdenum vanadium
Fluted Chambers	18
Trigger	5.6-10 pounds
Colors	Black, green, camo
Weight Empty	7.73 pounds
Additional	Barrel has 15x1 RHM threaded end and pinned muzzle brake.
Includes	Rugged plastic carry case, three (3) 10-round magazines, factory cleaning kit, two (2) extra take-down pins, factory Picatinny style optics mount, factory sling, and 5-year warranty.



# ESSENTIAL FIREARM SAFETY GUIDELINES

## Zenith Firearms

These firearm safety guidelines have been prepared by Zenith Firearms, based upon currently available information. They are provided to you as a courtesy and in the interest of furthering safety. These guidelines are not comprehensive, nor do they modify or replace rules, recommendations, standards, or regulations made by legal authorities or manufacturers.

**ZENITH FIREARMS EXPRESSLY DISCLAIMS ANY LIABILITY, OBLIGATION, OR WARRANTY RELATED TO THE INFORMATION SET FORTH IN THESE GUIDELINES.**

As a responsible firearms supplier, Zenith believes that no issue is more important than firearm safety. We urge you to learn and practice the following guidelines and to make them your habit when handling firearms. This will help ensure safe handling of your firearm(s) and help prevent accidents. We also encourage you to complete an approved firearms safety-training course.

## THE 3 CARDINAL FIREARMS SAFETY RULES

### 1. Always Handle a Firearm as if it is Loaded

Even if you determine that a firearm is unloaded, always, always, always handle it like it IS loaded. When you handle a firearm, the first thing you should do (with the firearm pointed in a safe direction), is open the action to identify whether the firearm is loaded. If you do not know how to open the action, do not handle the firearm. And remember, removing a magazine alone does not make a firearm unloaded, as there may be a round in the chamber.

### 2. Always Keep Your Finger Out of the Trigger Guard and Off the Trigger Until You Are Ready to Shoot Your Target

Do not place your finger inside the trigger guard until you have placed a firearm's sights on your target and have decided to fire. The best place to rest your finger in the meantime is above the trigger guard along the frame. By waiting until you are aimed at your target, if the trigger were to be pressed, you will guarantee that a shot will travel safely in the direction of your intended target.



### **3. Always Keep a Firearm Pointed in a Safe Direction, Before and Beyond Your Target**

It is important to identify your actual target, but it is just as important to know what lies past and before your target. A safe direction is any direction where an unintentional discharge will not cause injury or damage. In determining a safe direction, remember that a round can ricochet off an object or go through walls, floors, ceilings, and windows. Whether in a house or outdoors, the safest direction is the muzzle angled down toward the floor. And never point at or cross the muzzle of a firearm (loaded or unloaded) at any part of any person's body—the laser rule!

## **ADDITIONAL SAFE AND PROPER HANDLING AND STORAGE OF FIREARMS AND AMMUNITION RULES**

### **Always Keep Children and Others Safe By Storing Firearms Secure and Away From Unauthorized Persons**

You should always store firearms and ammunition out of the sight and reach of children and anyone else who is not an intended user or not physically or mentally capable of handling and using them properly and safely. Store firearms in a safe storage place—ideally, one you can lock.

### **Carefully Read the Entire Instruction Manual That Comes With Your Firearm**

You should only use a firearm if you fully understand how to safely operate it. All firearms come with an instruction manual created by the manufacturer. If the firearm does not come with an instruction manual, contact the manufacturer directly and request one.

### **Always Determine That the Firearm is Safe to Operate**

Before shooting, make sure the firearm is in good working order, that the barrel is clear, and that the firearm is safe to operate. This is especially important when handling a firearm that has been stored or unused for a long period of time.





## **Always Use Correct Ammunition**

Never use improper or incorrect ammunition. Only use ammunition recommended by the firearm manufacturer that is for the caliber of your firearm. Most firearms have the caliber engraved or stamped on the barrel. Your ammunition should be the exact same caliber. If you use the incorrect ammunition, it can destroy a firearm and cause serious injury.

## **When Cleaning a Firearm, Make Sure it is Not Loaded**

One of the most common statements following an accidental discharge is: "I was cleaning the gun and it went off!" When you clean a firearm, make sure it is not loaded. You should keep the ammunition in another room until you have finished cleaning the firearm and are ready to reload.

## **Never Use Firearms While Using Drugs or Alcohol**

When you handle firearms, your judgment must NOT be impaired. You should NEVER handle firearms while under the influence of alcohol, illegal drugs, or while using legal prescription medication that can make you tired or affect your senses, reflexes, or judgment.

## **Use Eye and Ear Protection**

Always wear proper eye and ear protection while shooting firearms; ear protection will help prevent hearing loss from the extreme decibel level of gunfire, and eye protection will help prevent ejection gases, ricocheted objects, casings, or any foreign objects from damaging your eyes. Be smart, be safe.

## Z-43 RIFLE MAJOR ASSEMBLY GROUPS



- |    |                                        |    |                        |
|----|----------------------------------------|----|------------------------|
| 1. | Receiver and Barrel Assembly           | 6. | Magazine Assembly      |
| 2. | Bolt Carrier Assembly                  | 7. | Picatinny Rail         |
| 3. | Trigger Housing and Buttstock Assembly | 8. | Take-down Pin          |
| 4. | Hand Guard                             | 9. | Recoil Spring Assembly |
| 5. | Take-down Pin                          |    |                        |

# 1. Receiver and Barrel Assembly

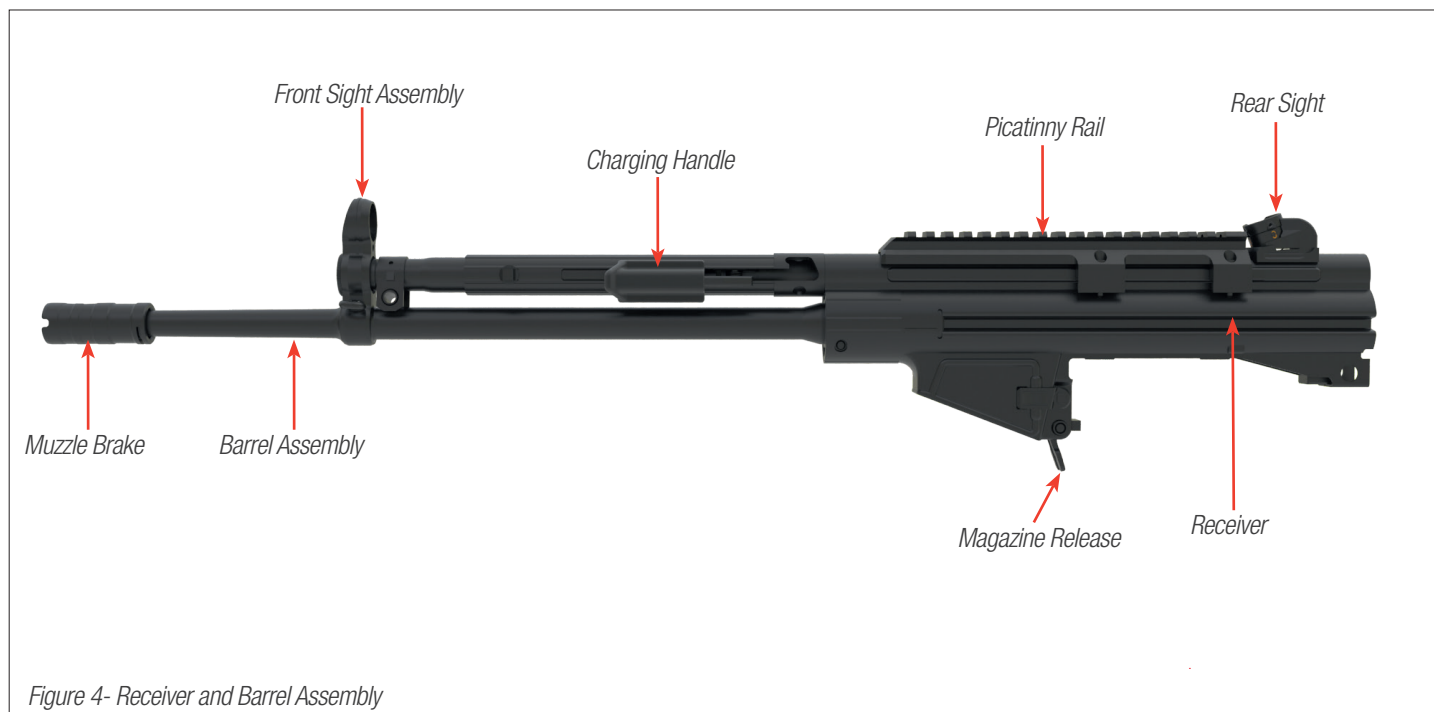

Figure 4- Receiver and Barrel Assembly

Barrel, charging (cocking) handle, Picatinny rail, and both sights are attached to the receiver. The muzzle brake is attached to the barrel end by way of a 15x1 RHM thread. It is held in place by a set screw with a 2 mm socket head screw.

The barrel is attached to the trunnion with a barrel retention pin (not removable). The charging handle is located above the barrel and is used to cycle the weapon and chamber a round and can be used to lock the bolt back to put the firearm in a safe condition.

The front sight is a fixed blade in a protected ring, and the rear sight is a protected drum, adjustable for windage and elevation. This drum has four apertures corresponding to 100, 200, 300, and 400 meters. The 100 meter is a V notch.

The Picatinny rail is attached to the receiver by way of four socket head cap screws and wedge-nuts.

# 2. Bolt Carrier Assembly



Figure 5- Bolt Carrier Assembly

The bolt carrier assembly slides into the receiver and retains the recoil spring. The bolt carrier assembly contains the bolt assembly and is moved forward under spring pressure. The bolt strips a round from the magazine feeding and chambering the next round, engages the rollers to lock the bolt, releases the firing pin to fire the weapon, and then moves rearward to eject the spent casing and re-cock the firing pin.

Bolt Carrier Assembly contains the following parts:

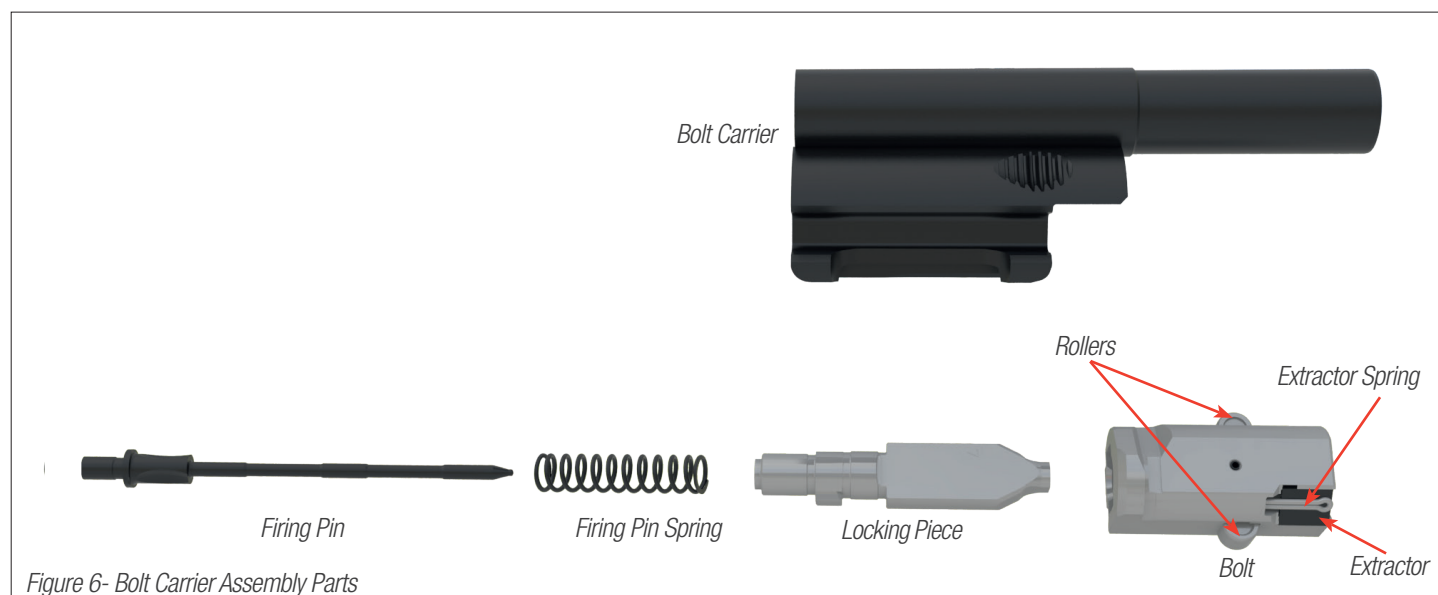

### 3. Trigger Housing and Buttstock Assembly

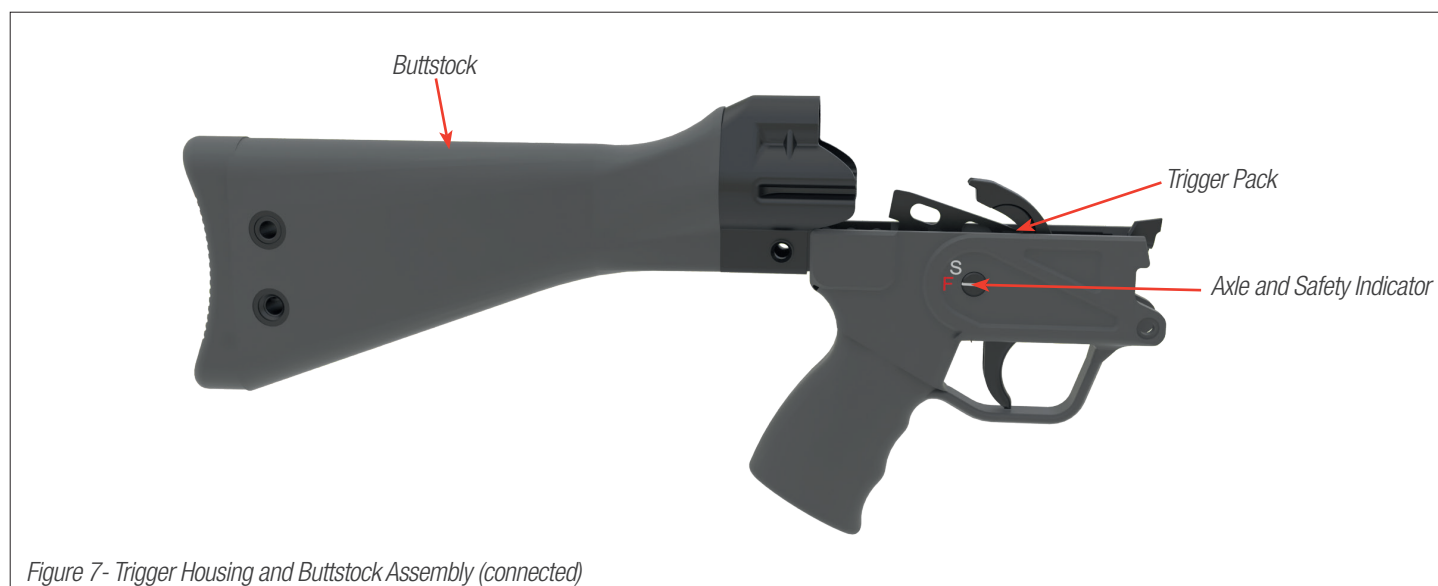

The trigger housing and buttstock are permanently connected in the sportorized version. Do not attempt to disassemble these two components. This component is held in place by two take-down pins that can be fully removed by sliding them out. Both pins can be temporarily stored in the two holes toward the rear of the buttstock. The trigger housing forms the pistol grip and contains the trigger pack and its associated parts, such as the hammer, trigger, and sears. It is recommended that a certified armorer initiate disassembly of the trigger pack.

## 4. Hand Guard

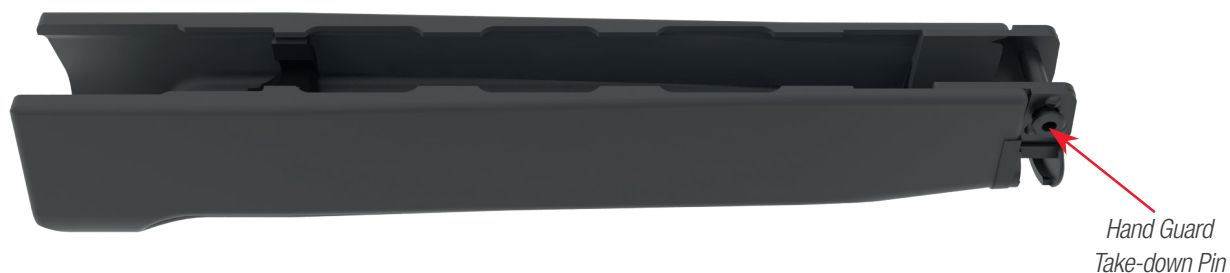

Figure 8- Hand Guard

The hand guard is attached under the barrel to the receiver and held in place by a pin. The hand guard protects the shooter from the heat of the barrel. There are several different hand guard options.

## 5. Recoil Spring Assembly



Figure 9- Recoil Spring Assembly

The recoil spring assembly is housed in the receiver behind the bolt carrier assembly. It mates with the bolt carrier assembly and both are manipulated with the charging handle. The recoil spring assembly absorbs recoil during firing and forces the bolt carrier forward feeding a round into the chamber. The charging handle is hinged and folds flat along the cocking tube when not being used.

## 6. Magazine Assembly



Figure 10- Magazine Assembly

The impact-resistant polycarbonate magazine holds 10 rounds and is either dark gray or amber in color.

Magazine Assembly contains the following parts:

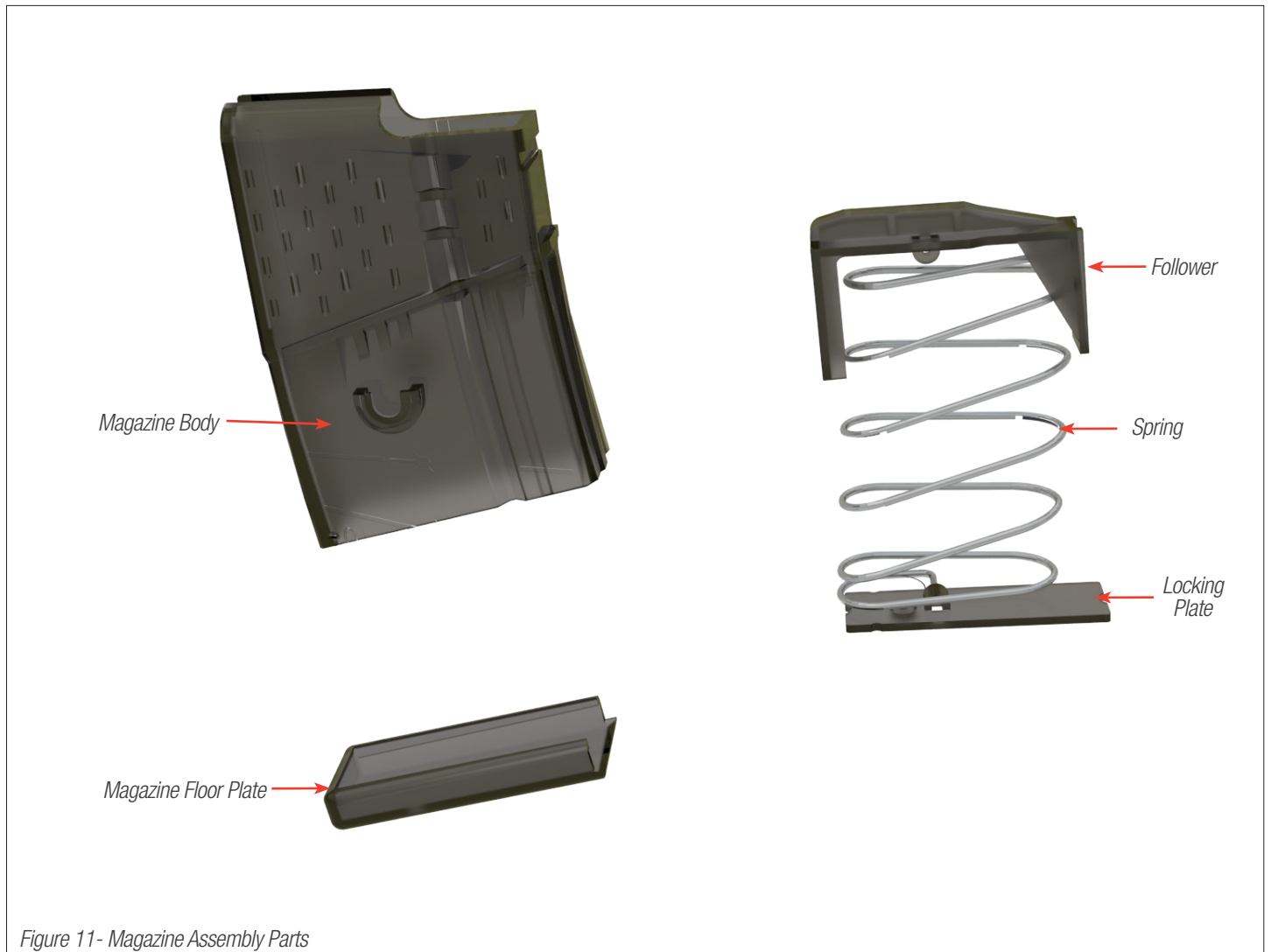

## 7. Picatinny Rail

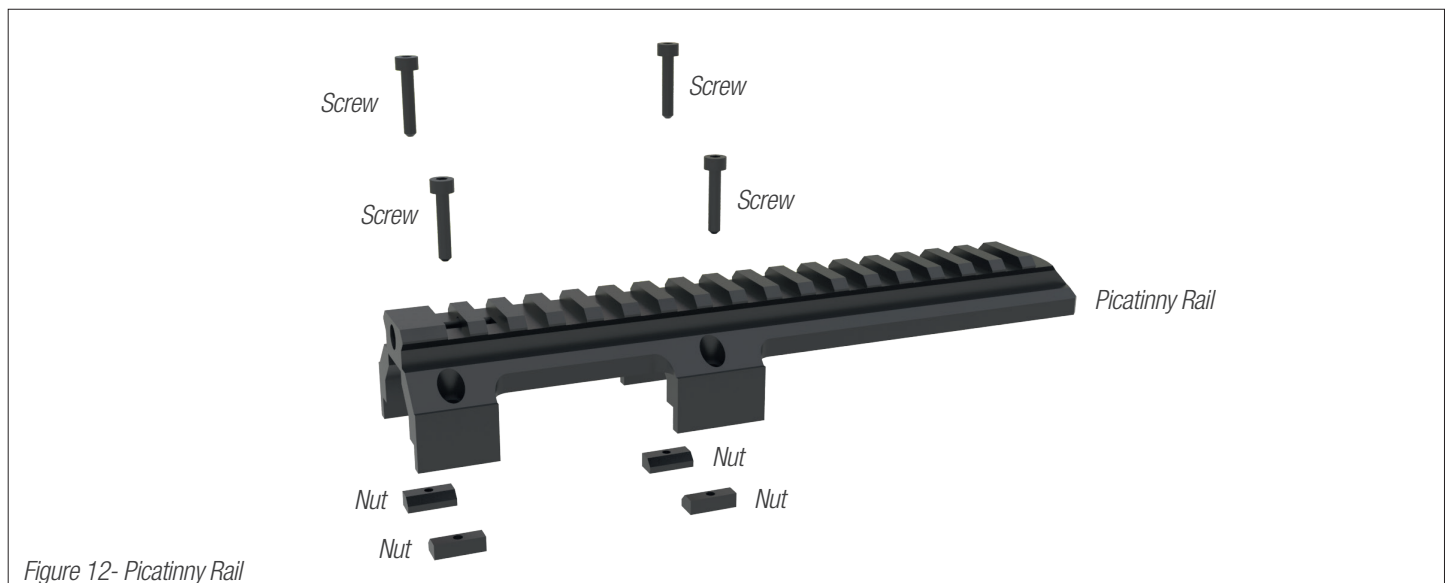

The Picatinny rail is manufactured to the MIL-STD-1913 and is attached to the top of the receiver by way of four socket head cap screws and four wedge-nuts that hold it firmly in place. This is used for quick connection of optics.

# Z-43 RIFLE DISASSEMBLY PROCEDURES

## 1. Magazine Removal



Press the magazine release button or paddle (see image a). Remove the magazine by pulling downward (see image b).

## 2. Trigger Housing and Buttstock Removal

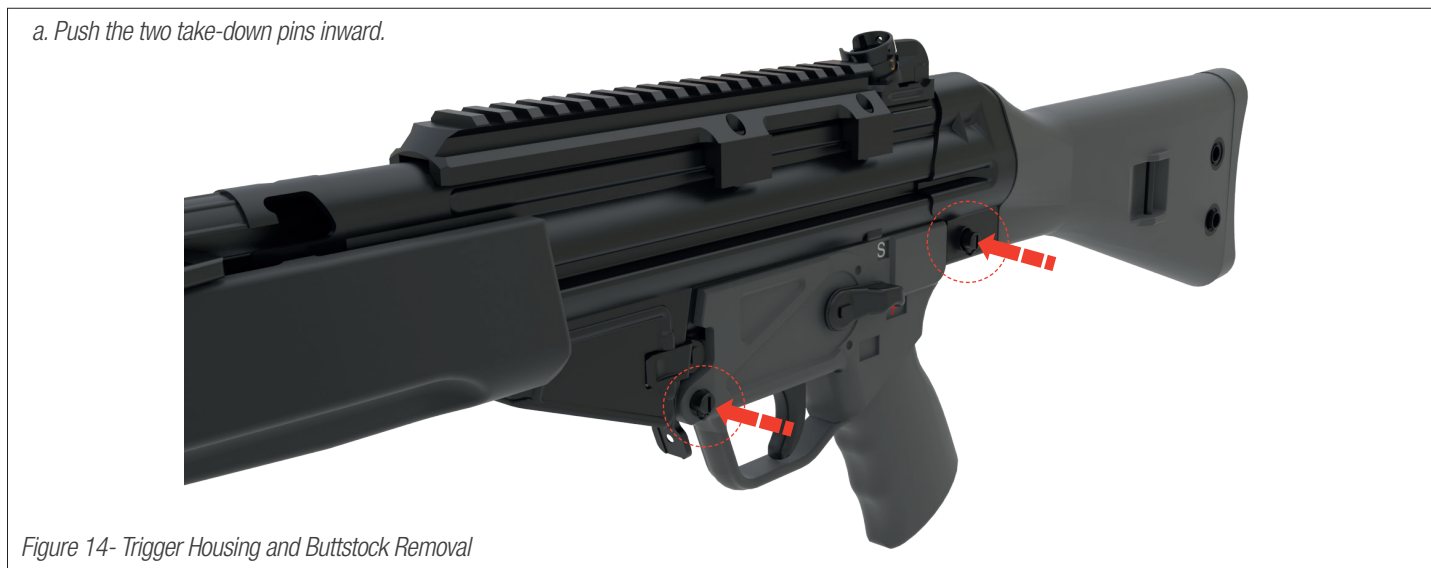

**CAUTION: ENSURE THE BOLT CARRIER IS IN THE FORWARD POSITION PRIOR TO REMOVING THE TAKEDOWN PINS.**

b. Pull the two take-down pins clear of the firearm.



c. Slide the trigger housing and buttstock assembly rearward and downward.



Figure 15- Trigger Housing and Buttstock Removal

Push the pins inward (see image a). On the other side of the firearm, pull the two take-down pins clear and insert in the two holes of the buttstock for temporary storage (see image b). Slide the trigger housing and buttstock assembly rearward and downward until separated (see image c).



### 3. Recoil Spring and Bolt Carrier Assembly Removal

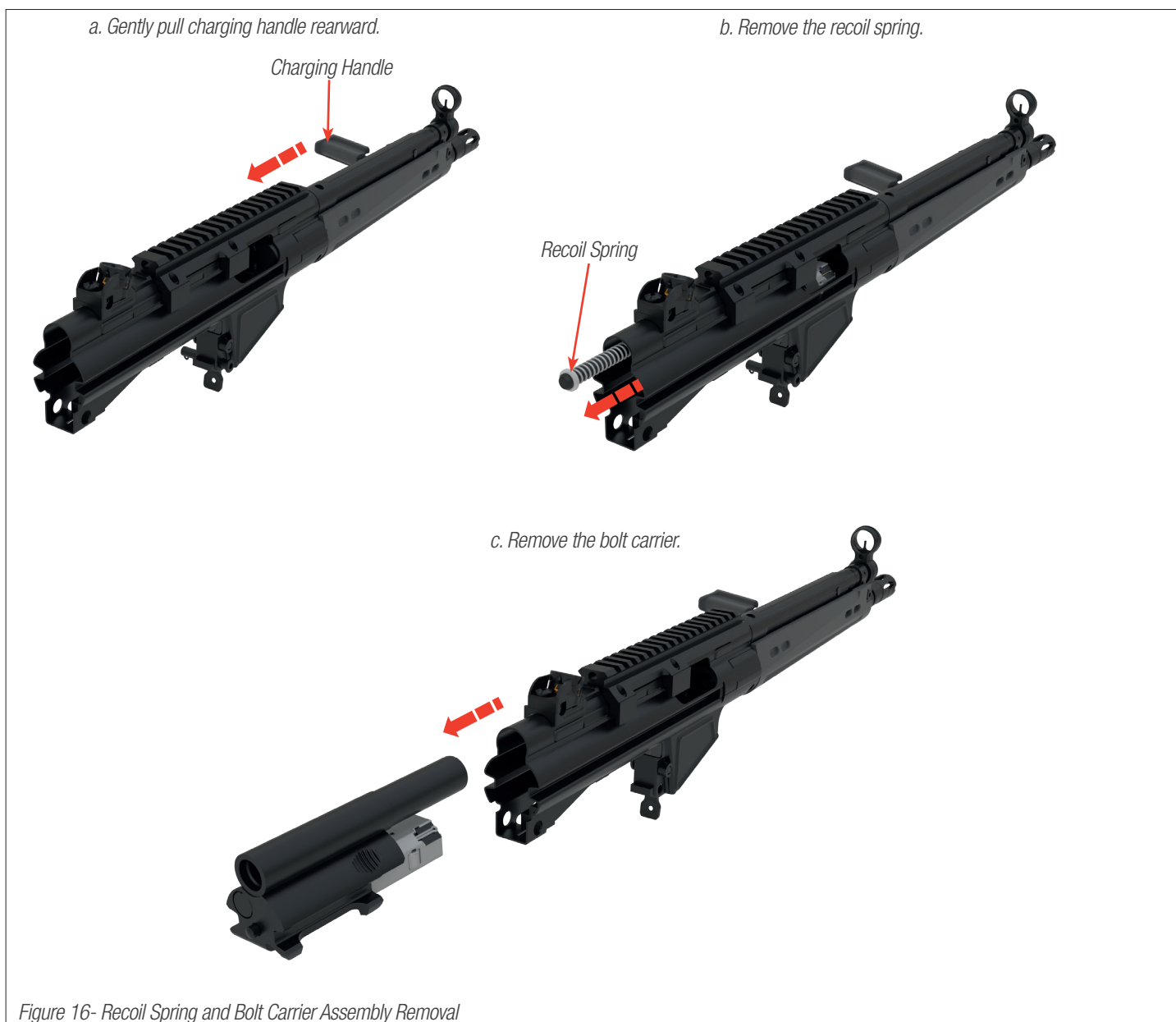
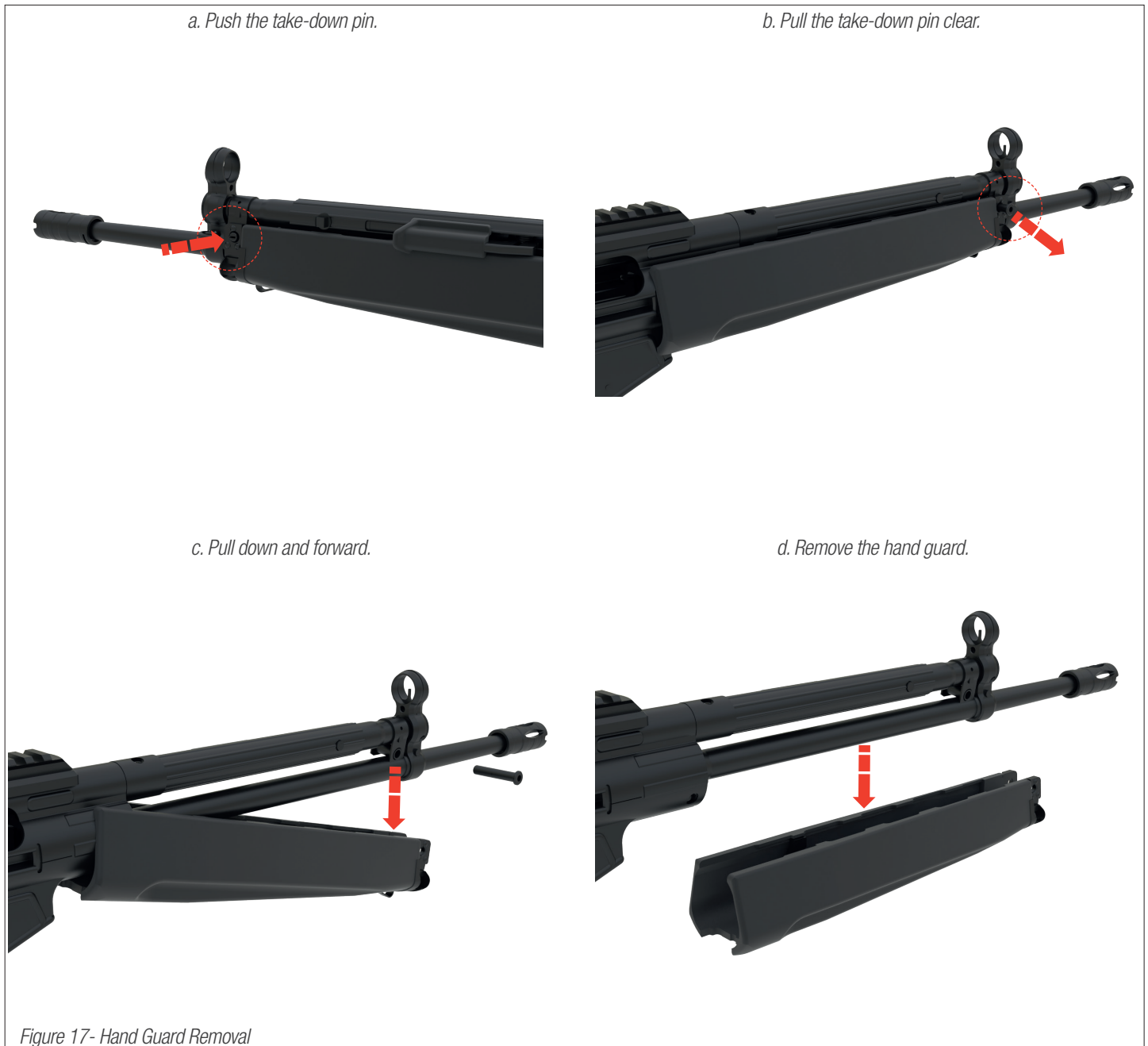

Figure 16- Recoil Spring and Bolt Carrier Assembly Removal

Begin by gently pulling on the recoil spring to remove from the receiver (see image a). Pull on the charging handle so the bolt carrier assembly comes free from the receiver (see images b and c).

## 4. Hand Guard Removal



Push the take-down pin inward (see image a). Pull the take-down pin clear of the rifle (see image b). Pull down and forward on the hand guard and the hand guard will slide off of the receiver (see image c and d).

## Z-43 RIFLE REASSEMBLY

Reassemble the rifle in reverse order of disassembly.

 **CAUTION: DO NOT USE EXCESSIVE FORCE WHEN DISASSEMBLING, ASSEMBLING OR CLEANING THE FIREARM.**

 **CAUTION: THE BARREL MAY BE HOT IF RECENTLY FIRED.**

# Z-43P PISTOL MAJOR ASSEMBLY GROUPS



Figure 18- Z-43P Pistol Major Assembly Groups

- |                                 |                            |
|---------------------------------|----------------------------|
| 1. Receiver and Barrel Assembly | 6. Take-down Pin           |
| 2. Bolt Carrier Assembly        | 7. Magazine Assembly       |
| 3. Trigger Housing Assembly     | 8. Picatinny Rail          |
| 4. Butt Cap                     | 9. Rear Take-down Pin      |
| 5. Hand Guard                   | 10. Recoil Spring Assembly |

# 1. Receiver and Barrel Assembly

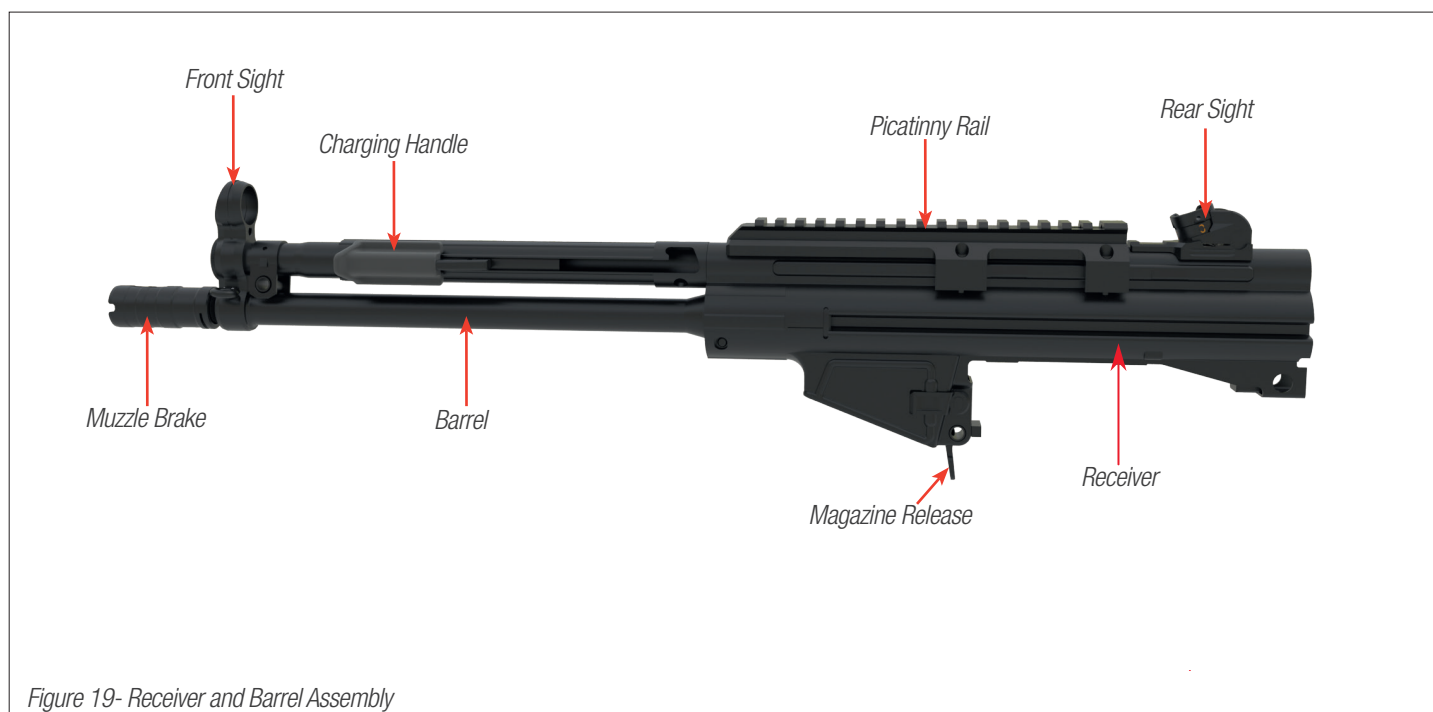

Figure 19- Receiver and Barrel Assembly

Barrel, charging (cocking) handle, Picatinny rail, and both sights are attached to the receiver. The muzzle brake is attached to the barrel end by way of a 15x1 RHM thread. It is held in place by a set screw with a 2 mm socket head screw.

The barrel is attached to the trunnion with a barrel retention pin (not removable). The charging handle is located above the barrel and is used to cycle the weapon and chamber a round and can be used to lock the bolt back to put the firearm in a safe condition.

The front sight is a fixed blade in a protected ring, and the rear sight is a protected drum, adjustable for windage and elevation. This drum has four apertures corresponding to 100, 200, 300, and 400 meters. The 100 meter is a V notch.

The Picatinny rail is attached to the receiver by way of four socket head cap screws and wedge-nuts.

## 2. Bolt Carrier Assembly



Figure 20- Bolt Carrier Assembly

The bolt carrier assembly slides into the receiver and retains the recoil spring. The bolt carrier assembly contains the bolt assembly and is moved forward under spring pressure. The bolt strips a round from the magazine feeding and chambering the next round, engages the rollers to lock the bolt, releases the firing pin to fire the weapon, and then moves rearward to eject the spent casing and re-cock the firing pin.

Bolt Carrier Assembly contains the following parts:

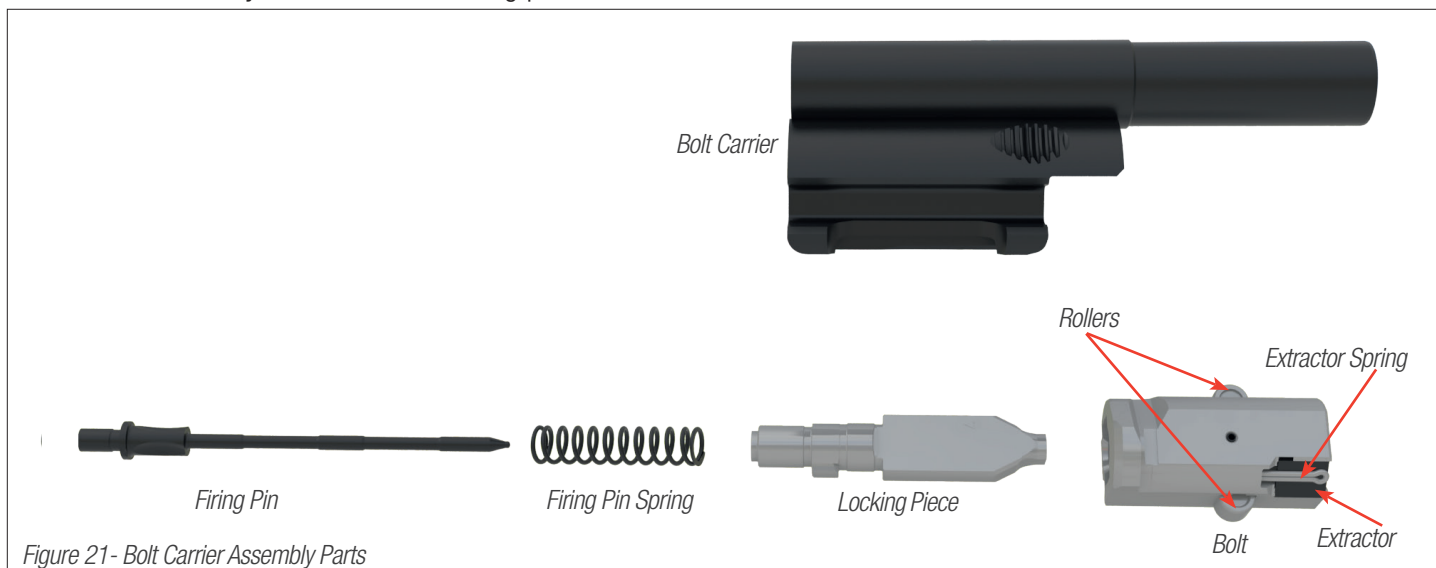

### 3. Trigger Housing Assmebly



The trigger housing is held in place by two take-down pins that can be fully removed by sliding them out. The trigger, housing forms the pistol grip and contains the trigger pack and its associated parts, such as the hammer, trigger and sears. Removal of the axle facilitates removal of the trigger pack. It is recommended that a certified armorer initiate disassembly of the trigger pack.

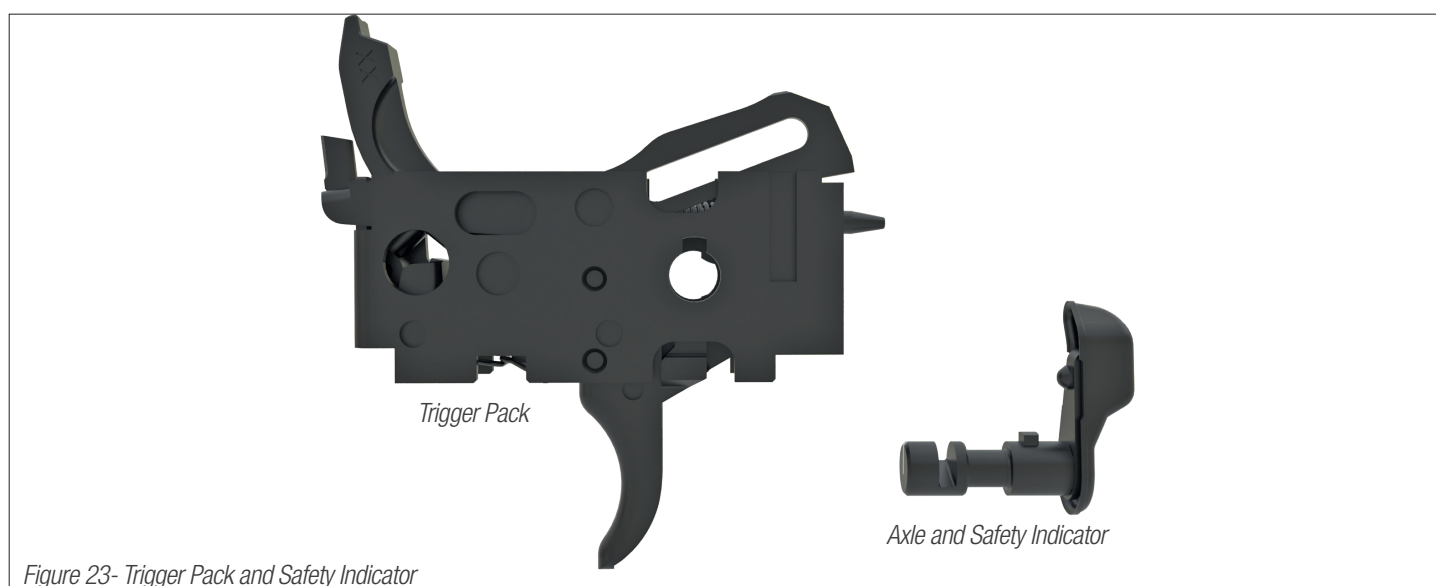

## 4. Butt Cap



Figure 24- Butt Cap

This component is held in place at the rear end of the receiver by a take-down pin that can be fully removed by sliding it out.

## 5. Hand Guard

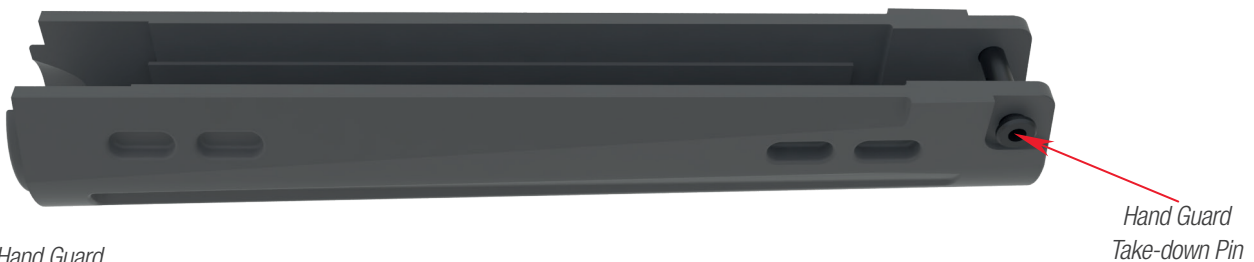

Figure 25- Hand Guard

The hand guard is attached under the barrel to the receiver and held in place by a pin. The hand guard protects the shooter from the heat of the barrel. There are several different hand guard options.

## 6. Recoil Spring Assembly



Figure 26- Recoil Spring Assembly

The recoil spring assembly is housed in the receiver behind the bolt carrier assembly. It mates with the bolt carrier assembly and both are manipulated with the charging handle. The charging handle is hinged and folds flat along the cocking tube when not being used. The recoil spring assembly absorbs recoil and forces the bolt carrier forward loading a round into the chamber.

## 7. Magazine Assembly



Figure 27- Magazine Assembly

The impact-resistant polycarbonate magazine holds 30 rounds and is either dark gray or amber in color.



Magazine Assembly contains the following parts:



## 8. Picatinny Rail

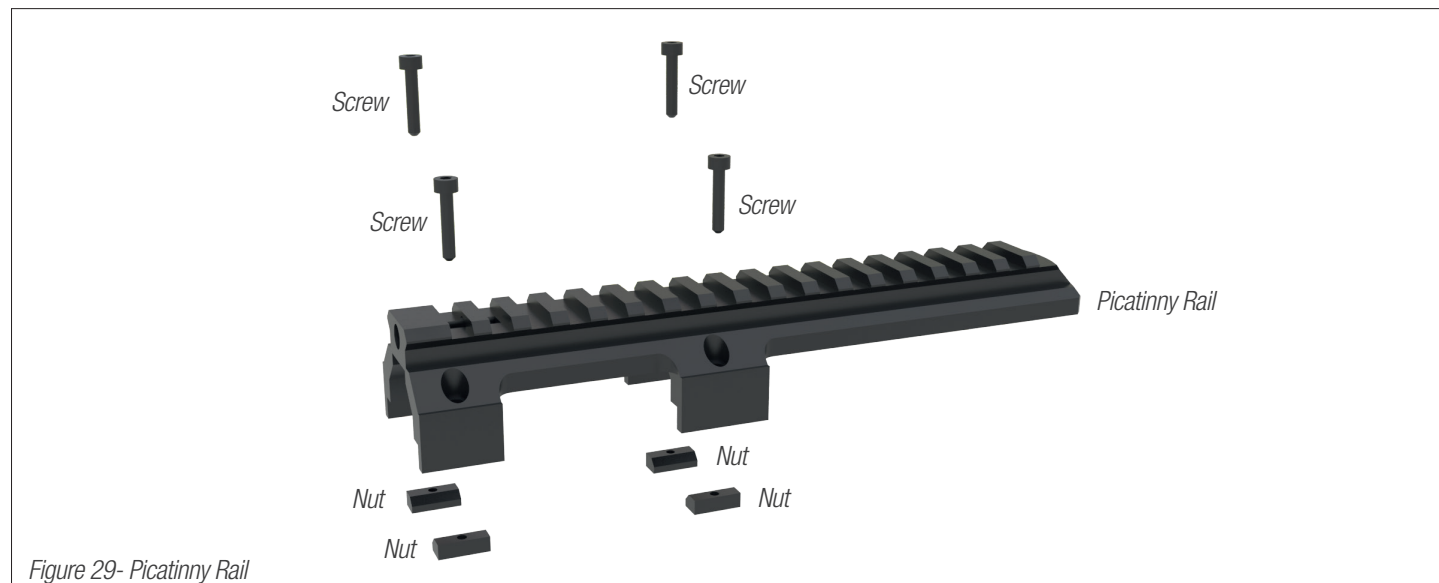

The Picatinny rail is manufactured to the MIL-STD-1913 and is attached to the top of the receiver by way of four socket head cap screws and four wedge-nuts that hold it firmly in place. This is used for quick connection of optics.

# Z-43P PISTOL DISASSEMBLY PROCEDURES

## 1. Magazine Removal



Press the magazine release button or paddle (see image a). Remove the magazine by pulling downward (see image b).

## 2. Butt Cap Removal



Push the pin inward (see image a). On the other side of the firearm, remove the take-down pin (see image b). Slide butt cap rearward until separated (see image c).



### 3. Recoil Spring and Bolt Carrier Removal

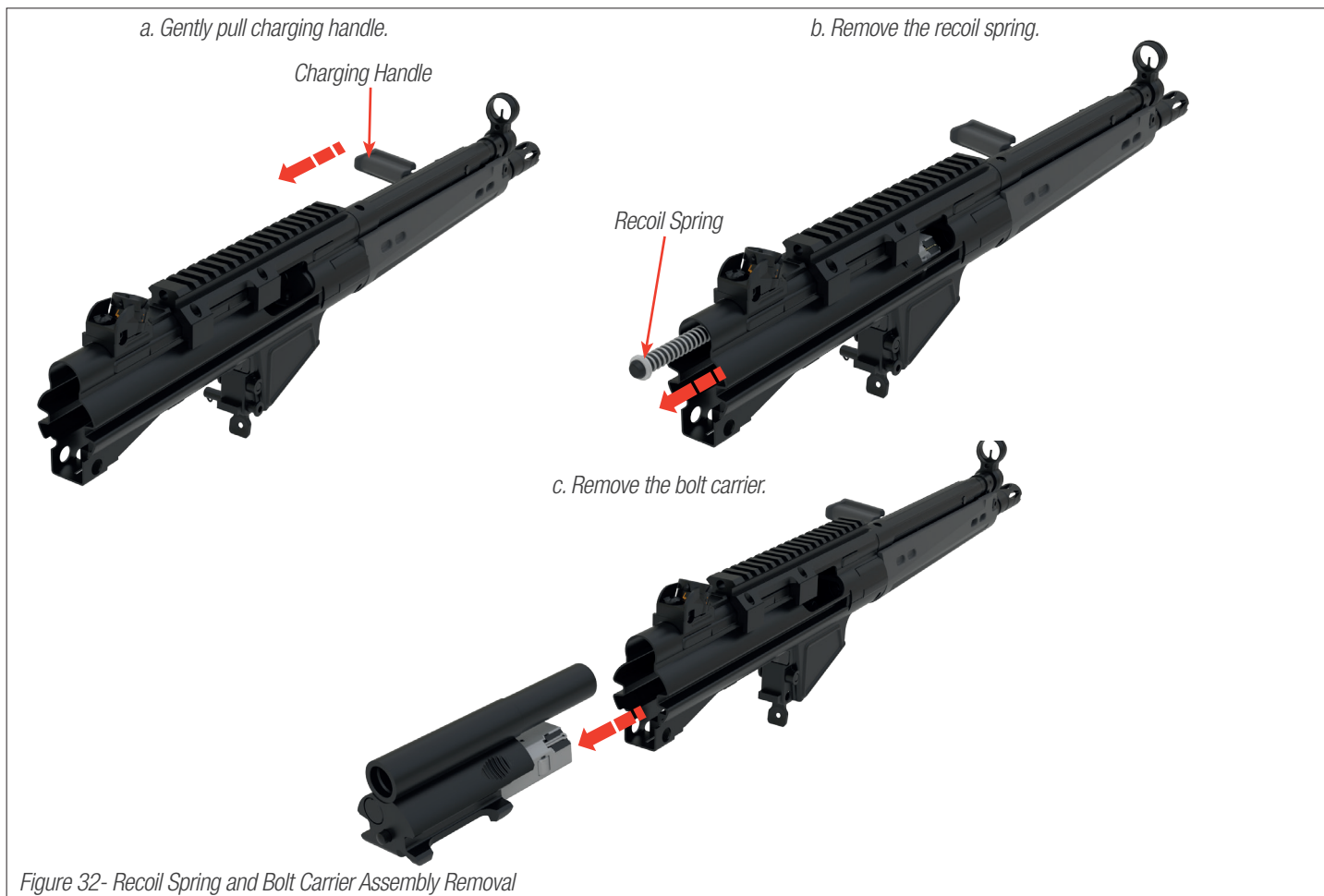

Begin by gently pulling the charging handle (see image a). Remove the recoil spring and the bolt carrier (see images b and c).

### 4. Trigger Housing Removal

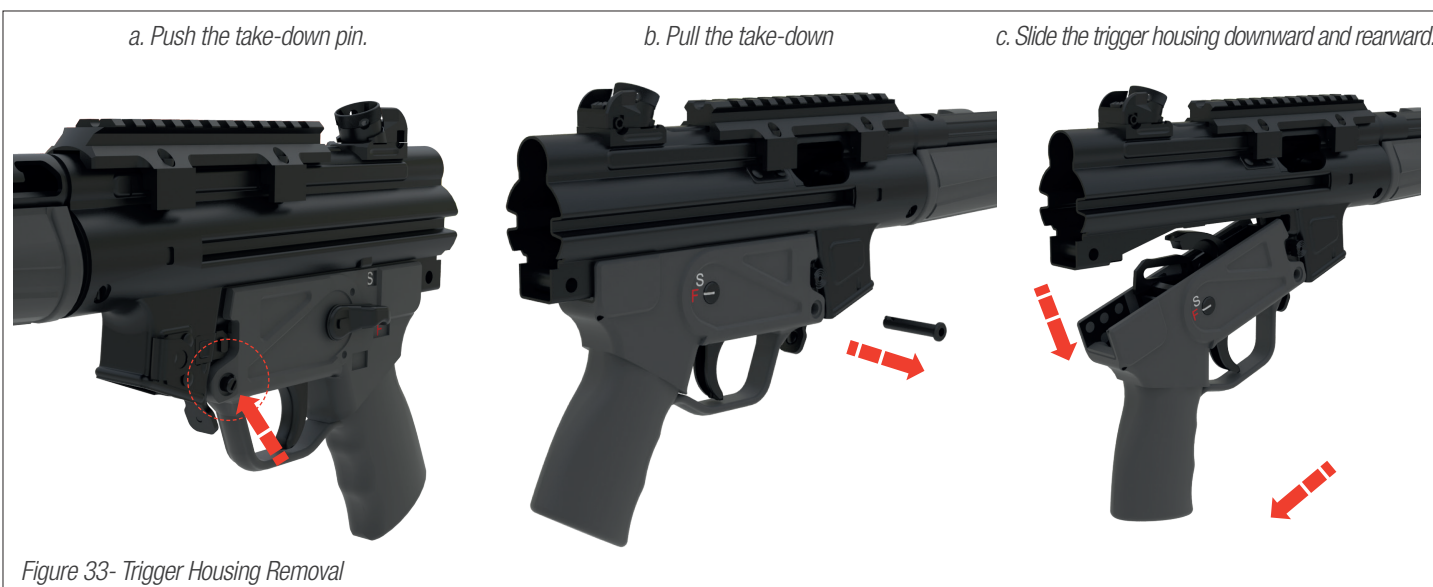

Push the pin inward (see image a). On the other side of the firearm, pull the pin clear (see image b). Slide the trigger housing downward and rearward until separated (see image c).

## 5. Hand Guard Removal

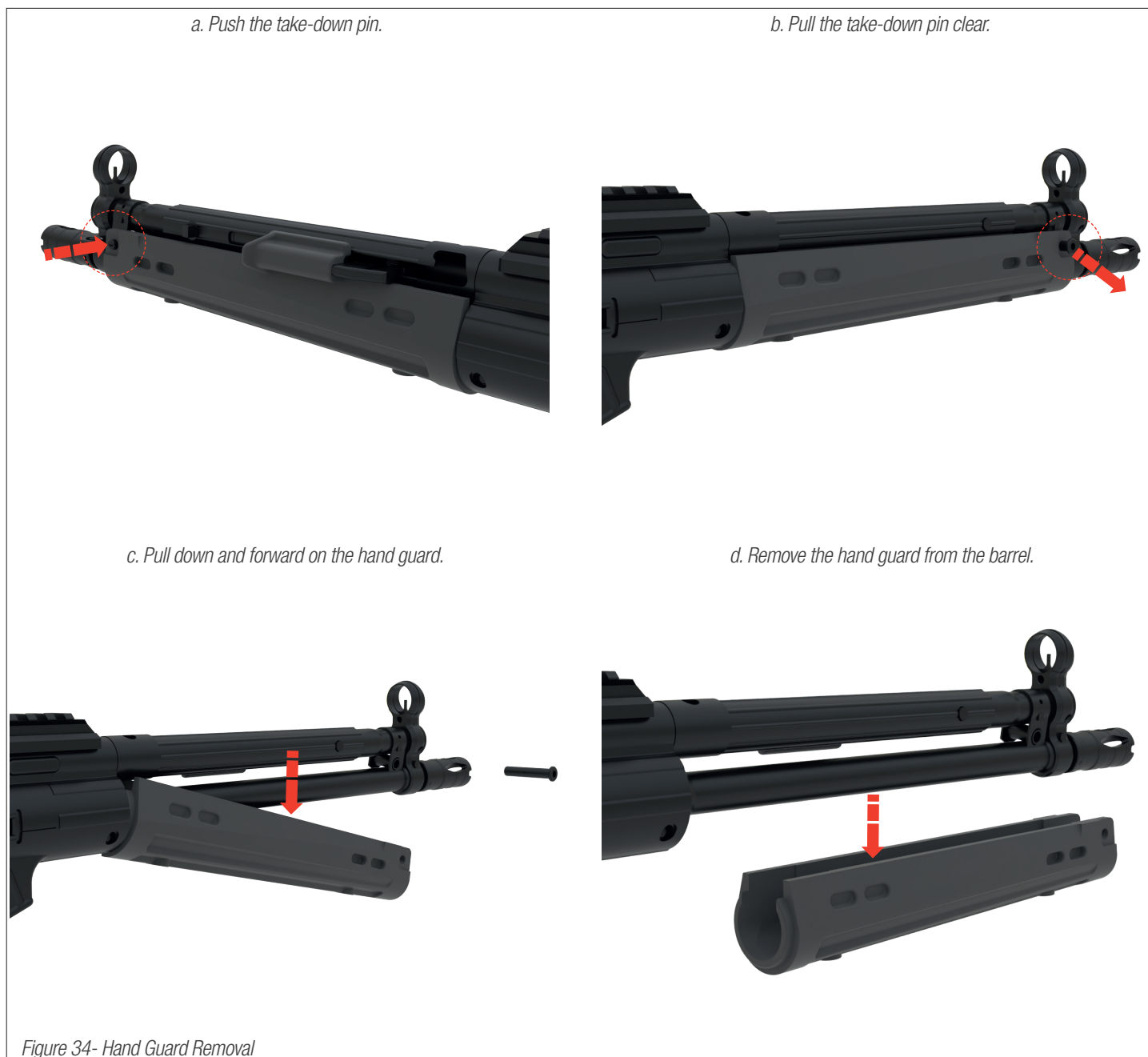

Push the take-down pin inward (see image a). Pull the take-down pin clear of the pistol (see image b). Pull down and forward on the hand guard and the hand guard will slide off of the receiver (see image c and d).

## Z-43P PISTOL REASSEMBLY

Reassemble the pistol in reverse order of disassembly.

 **CAUTION: DO NOT USE EXCESSIVE FORCE WHEN DISASSEMBLING, ASSEMBLING, OR CLEANING THE FIREARM.**

 **CAUTION: THE BARREL MAY BE HOT IF RECENTLY FIRED.**



# Z-43 SERIES RIFLE & PISTOL OPERATION

NOTE: The following procedures apply to both the Z-43 rifle and the Z-43P pistol.

## Safe and Fire Selector Operation

### 1. Selecting the Firearm to Safe



Figure 35- Selecting the Firearm to Safe

To place the firearm on safe, flip the safety lever, located on the left side of the trigger housing, up to "S" (safe). This will lock the trigger and the firearm cannot be fired.

### 2. Selecting the Firearm to Semi-Auto Fire



Figure 36- Selecting the Firearm to Semi-Auto Fire

To place the firearm in the fire position, flip the safety lever, located on the left side of the trigger housing, down to "F" (fire) or "1" (1 round). This will select semi-auto fire mode, where one pull of the trigger will fire one round and reload the next round.

# Loading and Unloading the Magazine

a. Push one round at a time, with bullet tip forward, straight down onto the follower.

b. Allow each additional round to offset as they stagger filling the magazine.

c. To unload slide each round forward out of the magazine.

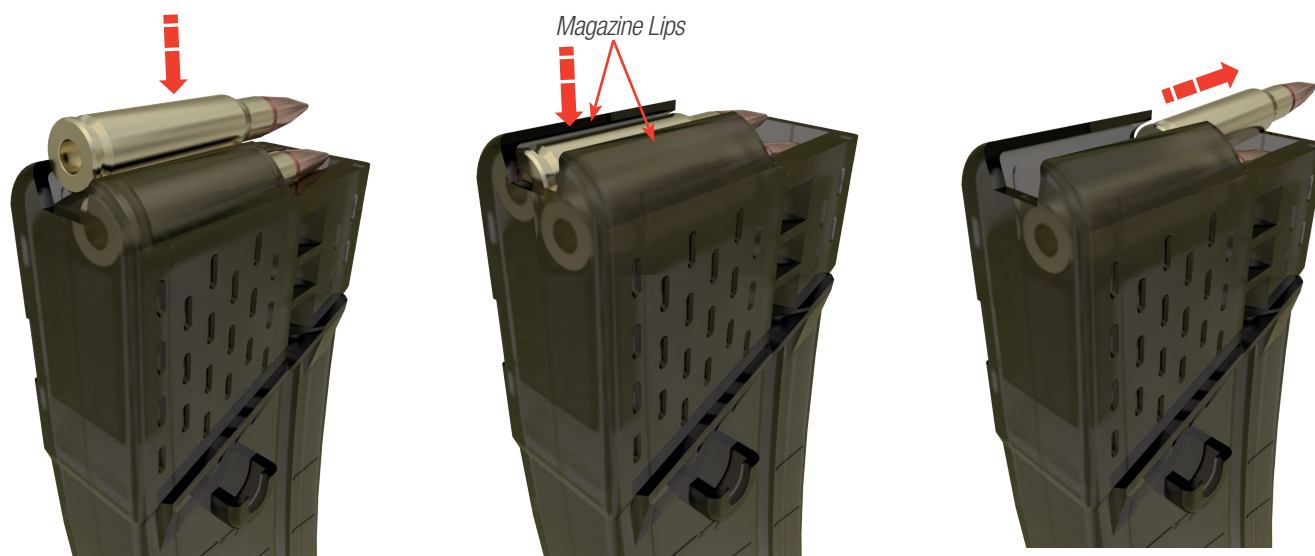

Figure 37- Loading and Unloading the Magazine

## 1. Loading the Magazine

Firmly grasp the magazine in the weak hand while using the thumb of the strong hand to push the first round between the lips of the magazine onto the follower. Use your thumb to push each additional round straight down, allowing the rounds to stagger as it fills. Ensure the rounds face forward toward the front of the magazine. Do not overload the magazine's capacity.

## 2. Unloading the Magazine

Firmly grasp the magazine in the weak hand while using the thumb of the strong hand to push the first round forward out from under the lips of the magazine. Continue to use your thumb to push each additional round straight out. Do not attempt to pull the rounds straight up to remove them.



**WARNING: NEVER USE DAMAGED OR INCOMPATIBLE AMMUNITION!**



**WARNING: NEVER USE ANY ITEM THAT MAY INADVERTENTLY STRIKE THE PRIMER WHEN UNLOADING CARTRIDGES FROM THE MAGAZINE.**

# Loading the Firearm

a. Ensure the firearm is selected to safe "S".

b. Pull the charging (cocking) handle rearward.

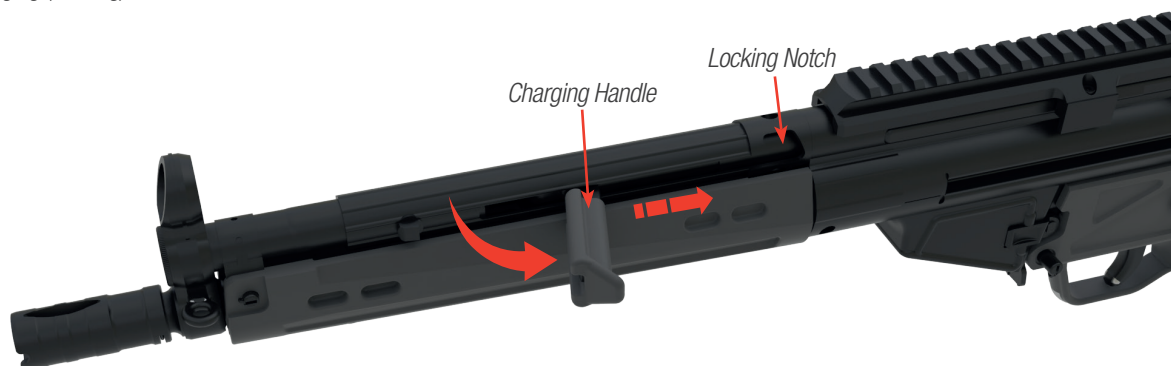

c. Engage charging handle into locking notch.



d. Insert the magazine into the magazine well until it locks in place.



Figure 38- Loading the Firearm

e. While holding the firearm in your strong hand, use the weak hand palm to strike the charging handle downward, disengaging it and allowing it to fly forward.



Figure 39- Loading the Firearm

Ensure the firearm safety "S" is engaged. While holding the pistol grip in the strong hand, use the weak hand palm to pull the charging (cocking) handle rearward (see image b). While still holding the cocking handle, pull up and engaging into the locking notch (see image c). Using your weak hand insert a loaded magazine into the magazine well, tugging on it to ensure it is locked (see image d). While holding the firearm in your strong hand, use the weak hand palm to strike the charging handle downward, disengaging it and allowing it to move freely forward (see image e). The firearm is now loaded and ready to fire. Moving the selector switch to fire will enable semi-auto fire.



**CAUTION: WHEN RELEASING THE CHARGING HANDLE, BE SURE TO AVOID PINCHING HAZARDS AS IT IS UNDER PRESSURE FROM THE RECOIL SPRING.**



**CAUTION: IT IS IMPORTANT TO ALLOW THE CHARGING HANDLE TO MOVE FREELY FORWARD UNDER SPRING TENSION.**



**CAUTION: DO NOT ATTEMPT TO EASE THE CHARGING HANDLE FORWARD AS THIS MAY CAUSE A MISFEED.**

## Firearm Operating System

Before firing, the bolt carrier and bolt are temporarily locked into the trunnion as the rollers are engaged by the locking piece. The trunnion is welded to the upper receiver stabilizing the barrel. The bolt remains locked until the bullet leaves the barrel and the pressure drops. At that point the the rollers disengage and the bolt carrier begins to move rearward by the force of the recoil.

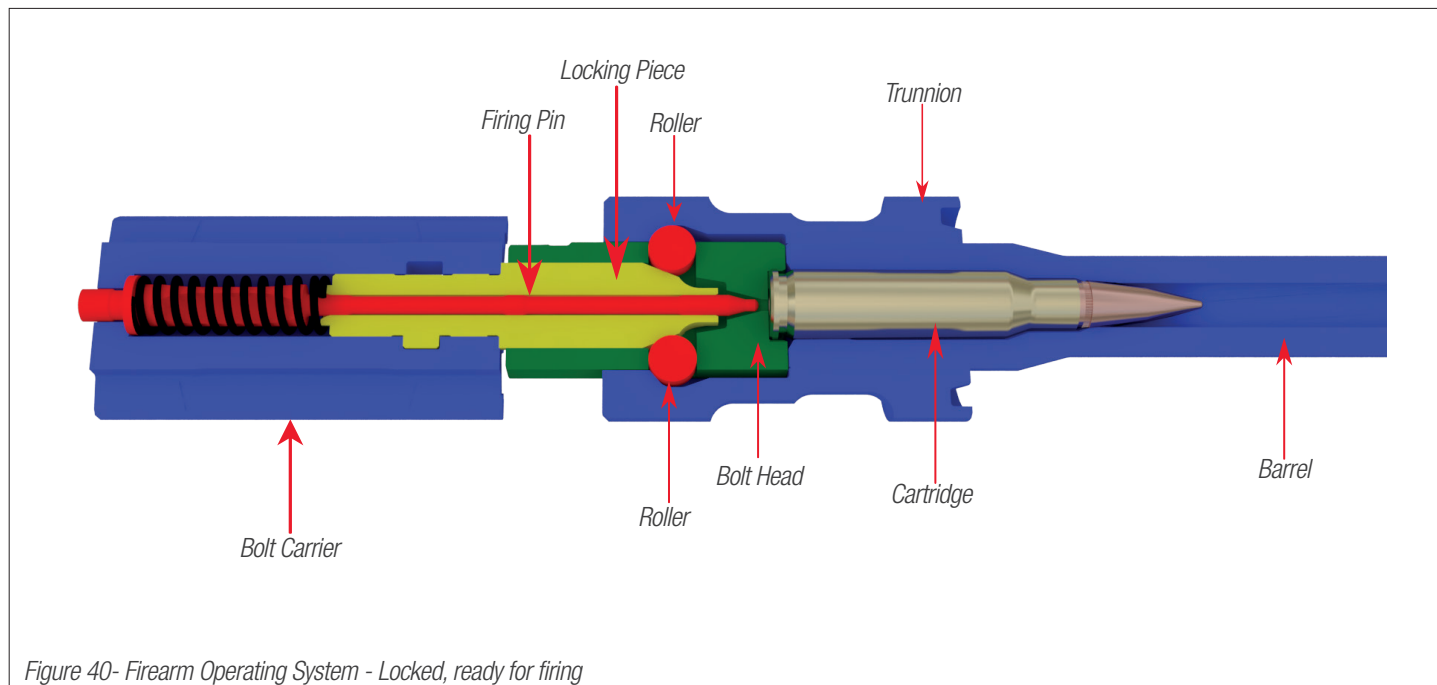

Figure 40- Firearm Operating System - Locked, ready for firing

In Figure 40, the system is locked and ready for firing.

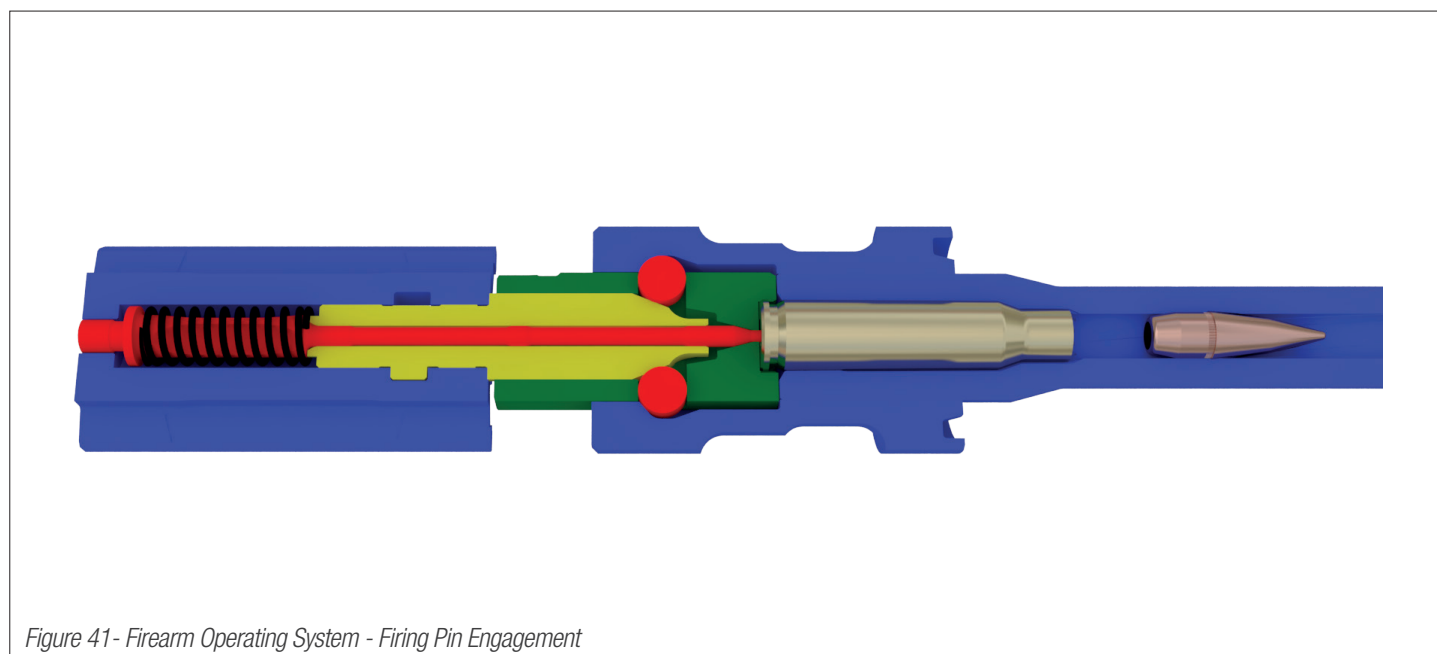

Figure 41- Firearm Operating System - Firing Pin Engagement

When the trigger is pulled, the firing pin is engaged by the hammer, striking the primer and initiating the burning of the powder, forcing the bullet down the barrel. At this time the lands and grooves of the barrel impart a spin to the bullet to stabilize it in flight. Gas is allowed to move around the cartridge case by way of flutes in the chamber, allowing the rollers to unlock and the case to move rearward against the face of the bolt.

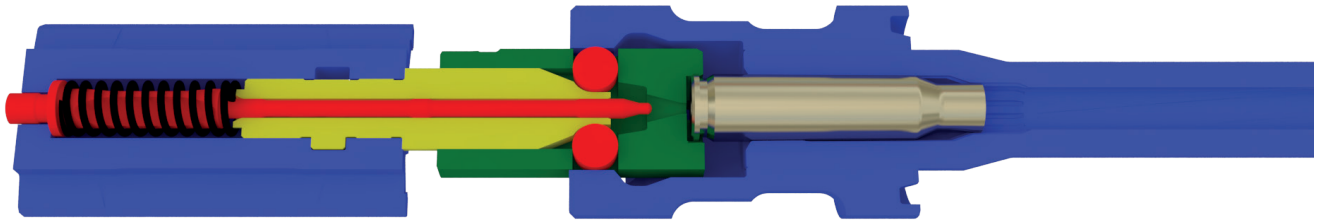

Figure 42- Firearm Operating System - Extraction

Once the bullet has left the barrel, the pressure drops allowing the rollers to disengage the locking piece, and the bolt carrier moves rearward.

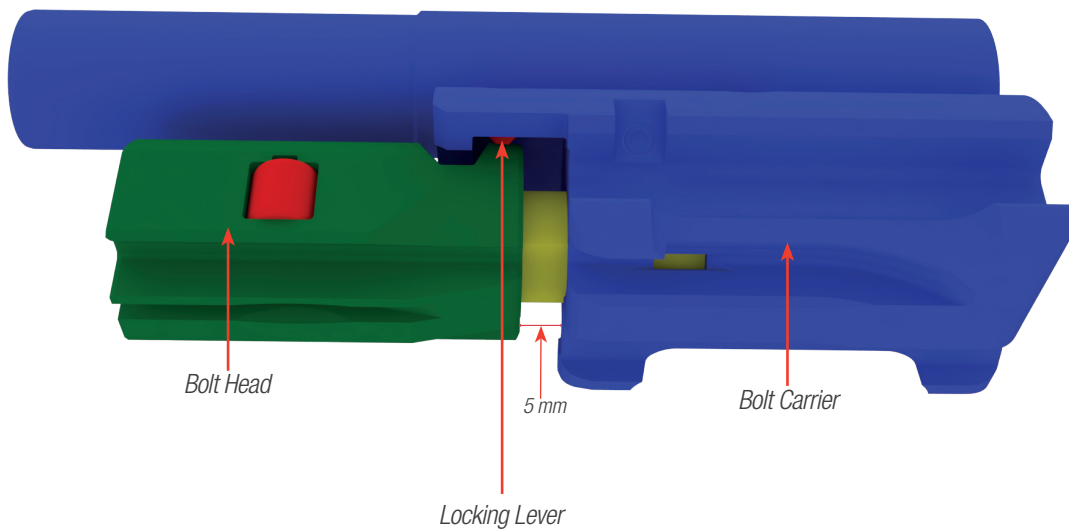

Figure 43- Firearm Operating System - Unlocked position of bolt

Once the bolt carrier moves rearward 5 mm, the bolt unlocks. As it continues to move rearward the recoil spring is compressed, the casing is extracted by the extractor and ejected by the ejector as the bolt moves past the ejection port. The hammer is cocked and the recoil spring and buffer limits rearward movement. The bolt carrier moves forward powered by the recoil spring and strips the next cartridge and feeds it into the chamber.



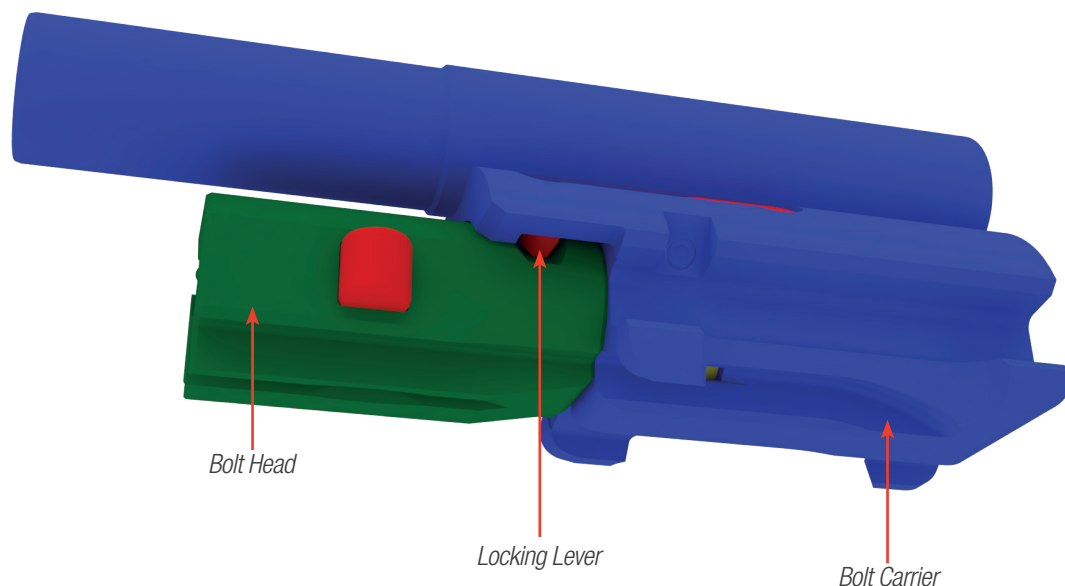

Figure 44- Firearm Operating System - Locked position of bolt

As the next round is pushed forward, the extractor locks onto the rim of the cartridge being chambered. The locking piece moves forward pushing the rollers outward to engage in their temporary locking position in the trunnion. At this time the gun is ready to be fired again.

## Trigger Operating System

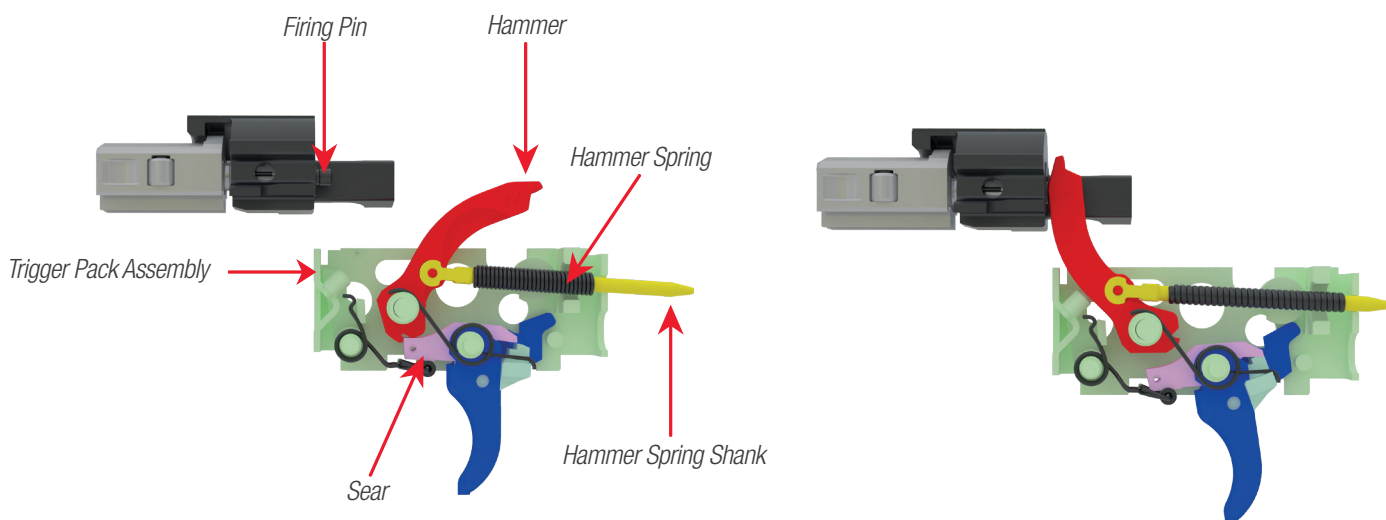

Figure 45- Trigger Operating System

The hammer spring is compressed and the hammer is held back by the sear. When the trigger is pulled, the sear is moved and the hammer is allowed to move forward, striking the rear of the firing pin with force. The firing pin strikes and ignites the primer and the round is fired beginning the process again.

# Z-43 RIFLE & Z-43P PISTOL SIGHTS

## Using the Sights

The rear sight has four apertures labeled 1, 2, 3, and 4. The number 1 has a V-notch designed for shooting up to 100 meters. The numbers 2, 3, and 4 represent 200, 300, and 400 meters.

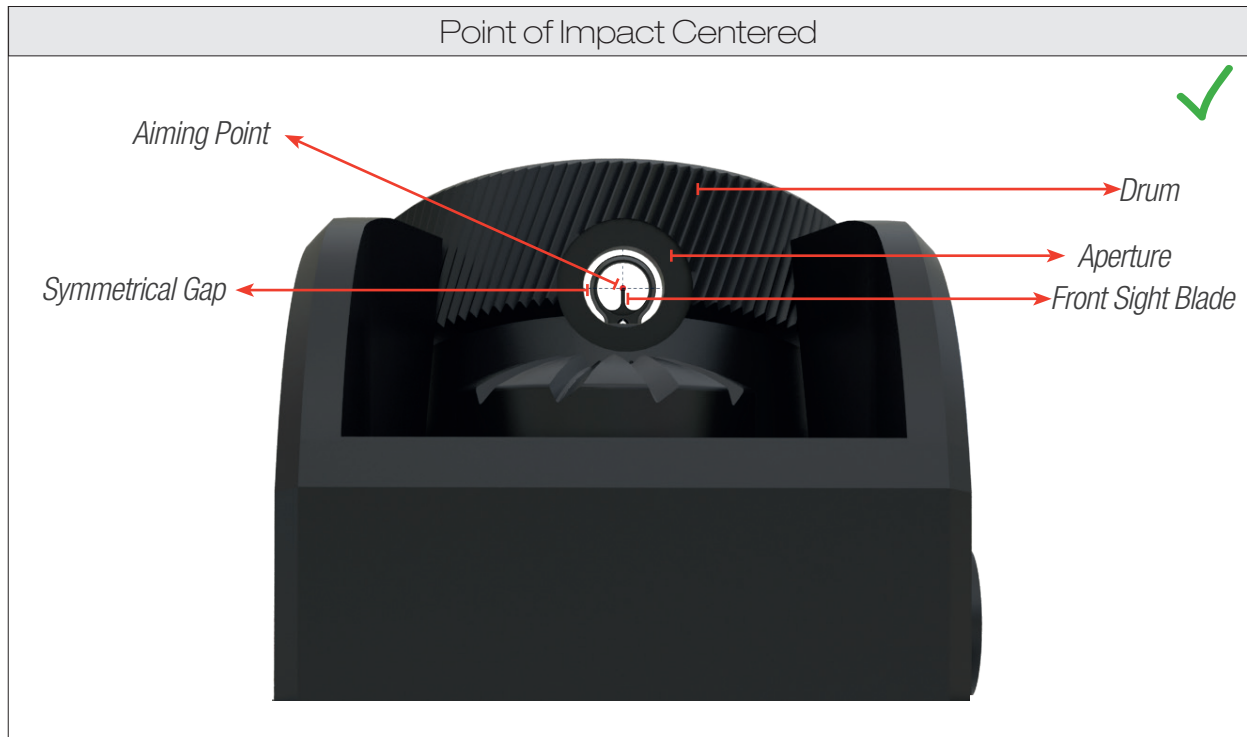



## Rear Sight Adjustments

Z-43 Series Rifles & Pistols are zeroed after production. If the sight requires adjustment for elevation or windage, this is done in the following manner.

### Windage Adjustment

To adjust the windage to the left, loosen the locking screw and gently turn the adjustment counter-clockwise. To adjust the windage to the right, loosen the locking screw and gently turn the adjustment clockwise. One quarter turn (one click) equals approximately 1.44 inch change in elevation or windage at 100 yards.



Figure 46- Windage Adjustment

### Elevation Adjustment

Elevation adjustment is made by use of an elevation adjustment tool. The elevation adjustment tool engages in the notches on the inside of the drum sight. All adjustments should be made with the rear drum placed on the #1. Turning the drum clockwise will lower the bullet's point of impact. Turning the drum counter-clockwise will raise the bullet's point of impact. One quarter turn (one click) equals approximately 1.44 inch change in elevation or windage at 100 yards.

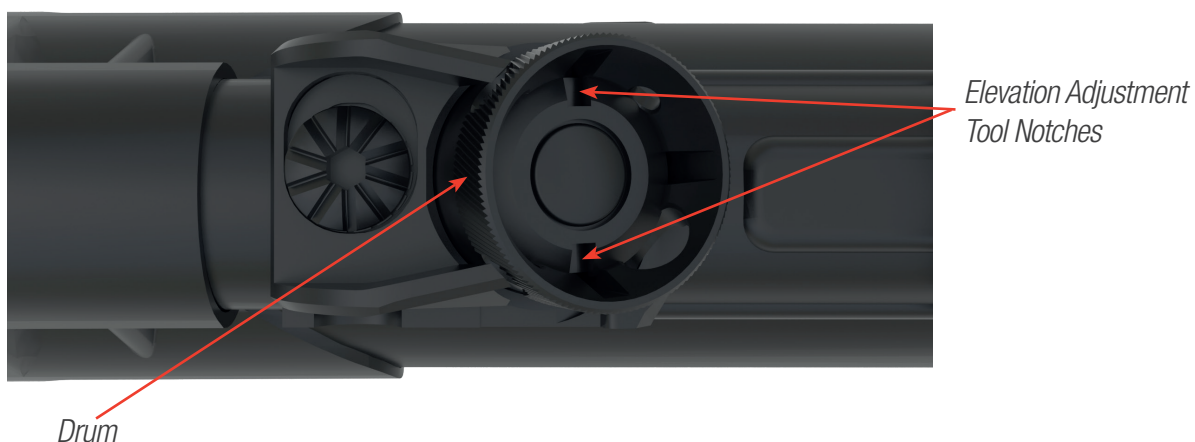

Figure 47- Elevation Adjustment



**CAUTION: IT IS RECOMMENDED TO USE A SIGHT ADJUSTMENT TOOL FOR ADJUSTING ELEVATION.**



# FIREARM MAINTENANCE

## Regular Maintenance

Always be aware of the overall operation of your firearm. Ensure the charging handle, safety selector, magazine insertion, etc. are in proper operating condition. If any strong resistance or odd tolerances are noted, investigate. In general keep your firearm clean and lubricated. When your firearm is disassembled, inspect for rust, corrosion, and build up of any residues that will affect operation. A function check should be performed. This entails ensuring the safety does not allow the trigger to be pulled.

## Prior to Use

Perform a regular maintenance and function check prior to use. Pay special attention to ensure there are no obstructions or mechanical situations that need to be addressed.

## After Each Use

After each firing session, the firearm should be unloaded, checked for clear, and field stripped. The firearm should then be cleaned, re-lubricated, and subjected a function check prior to storing.

# Extreme Climate Maintenance

## High Heat and Humid/Wet Conditions

In climates with high heat and humidity the firearm, and especially its internal components, can rust more quickly. Inspect your firearm more often and never leave components without lubrication. If any rust or corrosion is located, clean it off and re-lubricate immediately.

## High Heat and/or Low Humidity/Dry Conditions

In climates with high heat and/or low humidity, firearms are less likely to rust, however, lubrication can evaporate and dirt, sand, and other contaminants can find their way into the operation. This will cause faster wear and abrasion of the internal components. Use a thinner oil and wipe all excess oil after cleaning, as excess oil will attract and hold dirt.

## Extreme Cold Conditions

In climates with extreme cold and/or low humidity, the lubricating oils used should be selected specifically for this environment. Sudden temperature changes can cause moisture build-up inside the firearm leading to corrosion. For this reason attention must be paid for condensation both inside and out. Care must be taken to not place a hot, recently fired firearm in snow or ice as it could damage or deform metal surfaces. And upon transitioning from a cold environment to a warm environment condensation will occur and must be addressed with drying and lubrication.

# Disassembly and Maintenance of Bolt Carrier Assembly

## Disassembly of Bolt Carrier Assembly

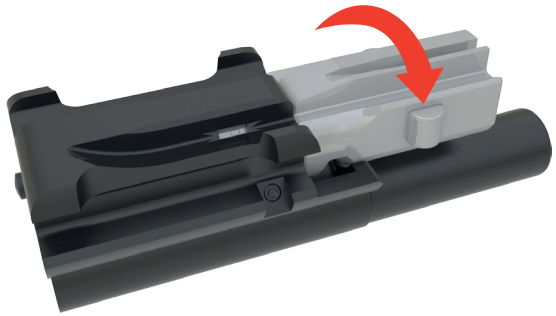
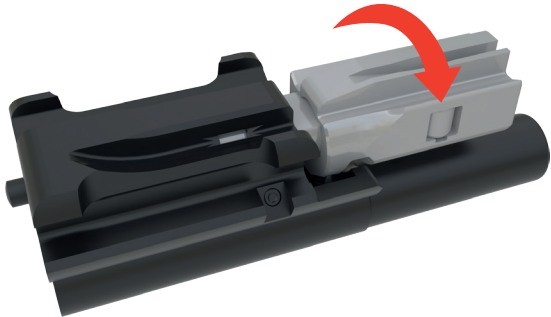
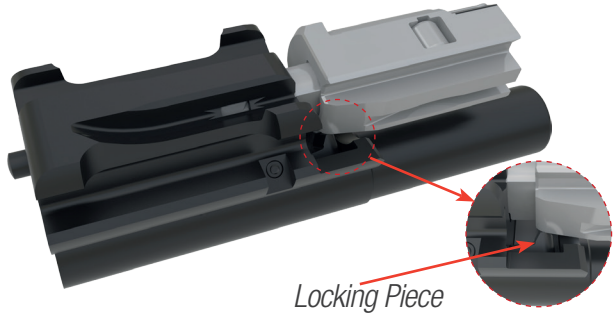
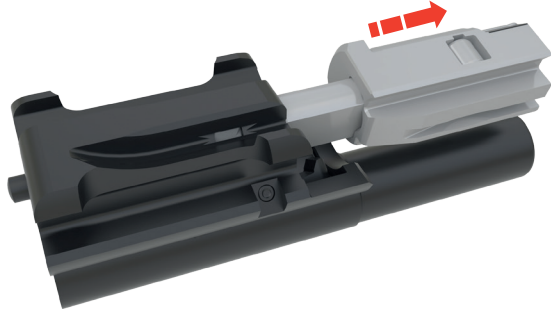
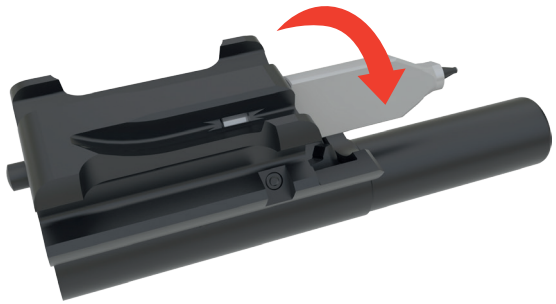
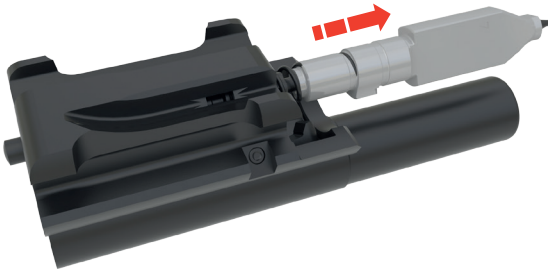
<p>a. Squeeze the two rollers on the bolt together.</p> 	<p>b. Separate the bolt from the carrier and rotate ~90 degrees in the direction of the arrow.</p> 
<p>c. Continue rotating the bolt until it disengages from the locking piece.</p>  <p>Locking Piece</p>	<p>d. Control bolt as it disengages from the carrier.</p> 
<p>e. If the locking piece does not free itself, continue rotating it until it is free.</p> 	<p>f. Allow the locking piece to disengage controlling it as it is under spring pressure.</p> 

g. Separate the firing pin and firing pin spring from the locking piece.



NOTE: It is highly recommended to utilize a bolt carrier assembly tool when removing the bolt from the bolt carrier assembly.

Figure 48- Disassembly of Bolt Carrier Assembly

Squeeze the two rollers together (see image a), pull the bolt away from the bolt carrier (see image b), and rotate the bolt ~90 degrees counter-clockwise (see image c). Control the bolt allowing it to separate from the carrier (see image d). Holding the locking piece firmly, continue to turn it until it unlocks and comes free of the carrier (see image e). Control the removal of the locking piece including the firing pin and firing pin spring (see figure f). Separate the firing pin and firing pin spring from the locking piece (see image g).

## Maintenance of Bolt Carrier Assembly

Once disassembled the bolt carrier should be cleaned to remove all carbon and unburned powder. Solvent and a brush may be used. After cleaning, a light coat of lubricant should be applied to all surfaces. Reassemble in reverse order from disassembly.

### Bolt Carrier Reassembly

Once cleaned, follow the reassembly show below.

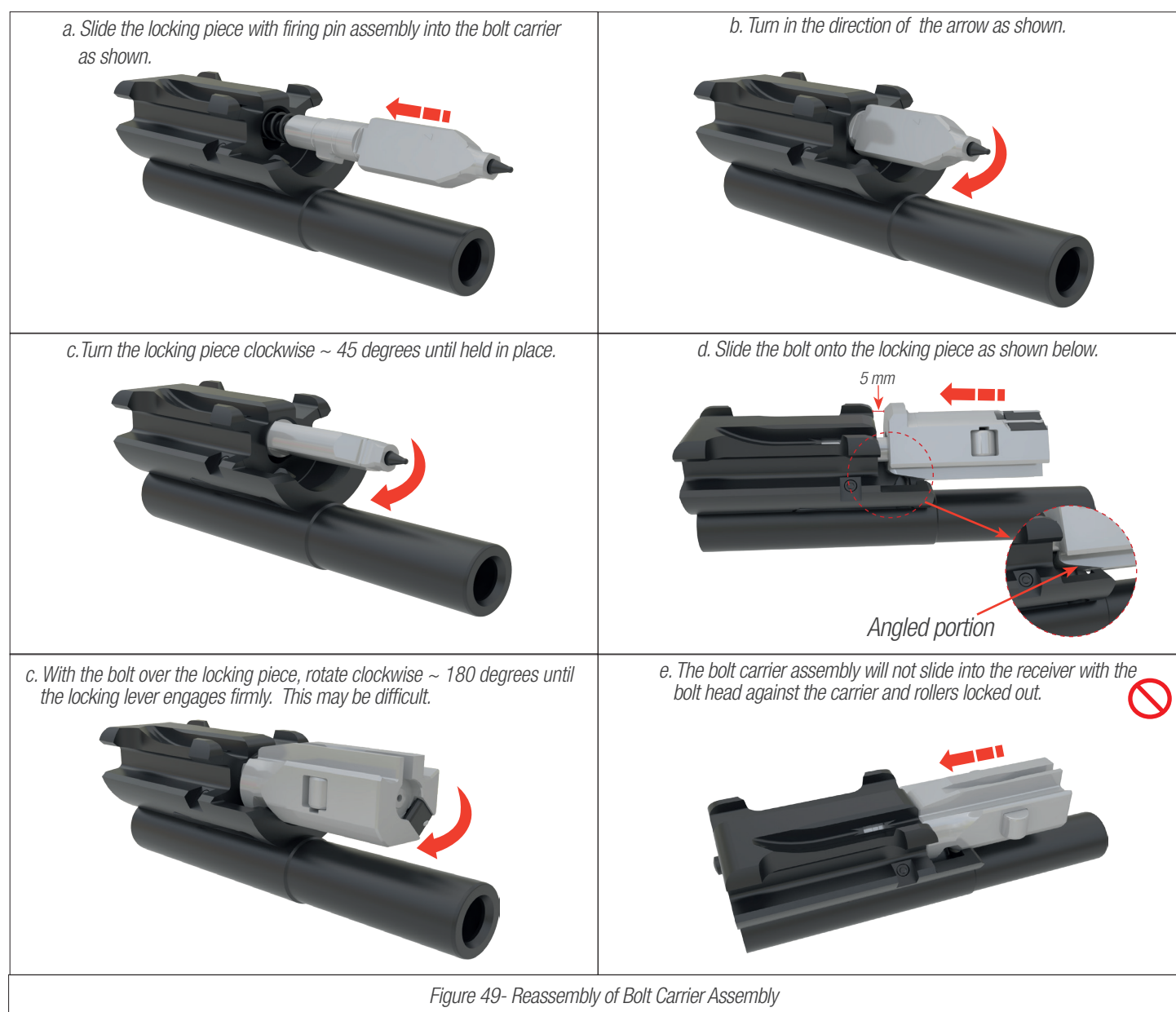

Figure 49- Reassembly of Bolt Carrier Assembly

NOTE: it is highly recommended to utilize a bolt carrier assembly tool when reassembling the bolt onto the bolt carrier assembly.



Slide the locking piece, including the firing pin assembly, into the bolt carrier (see image a). Turn the locking piece clockwise ~45 degrees until held in place (see image b and c). Slide the bolt over the locking piece and rotate clockwise ~180 degrees until the locking lever engages (see image d and e). Continue to rotate the bolt head over the locking piece maintaining an ~5 mm gap from the carrier so that the rollers remain unlocked (see image f).



**CAUTION: THE BOLT CARRIER ASSEMBLY WILL NOT SLIDE INTO THE RECEIVER WITH THE BOLT HEAD FLUSH AGAINST THE CARRIER AND ROLLERS LOCKED OUT. YOU MUST MAINTAIN AN ~5 MM GAP BETWEEN THE TWO (SEE IMAGE F).**

**NOTE: A BOLT CARRIER ASSEMBLY TOOL IS HIGHLY RECOMMENDED FOR THE ABOVE PROCEDURES.**

## Trigger Pack Removal and Maintenance

### Trigger Housing Removal

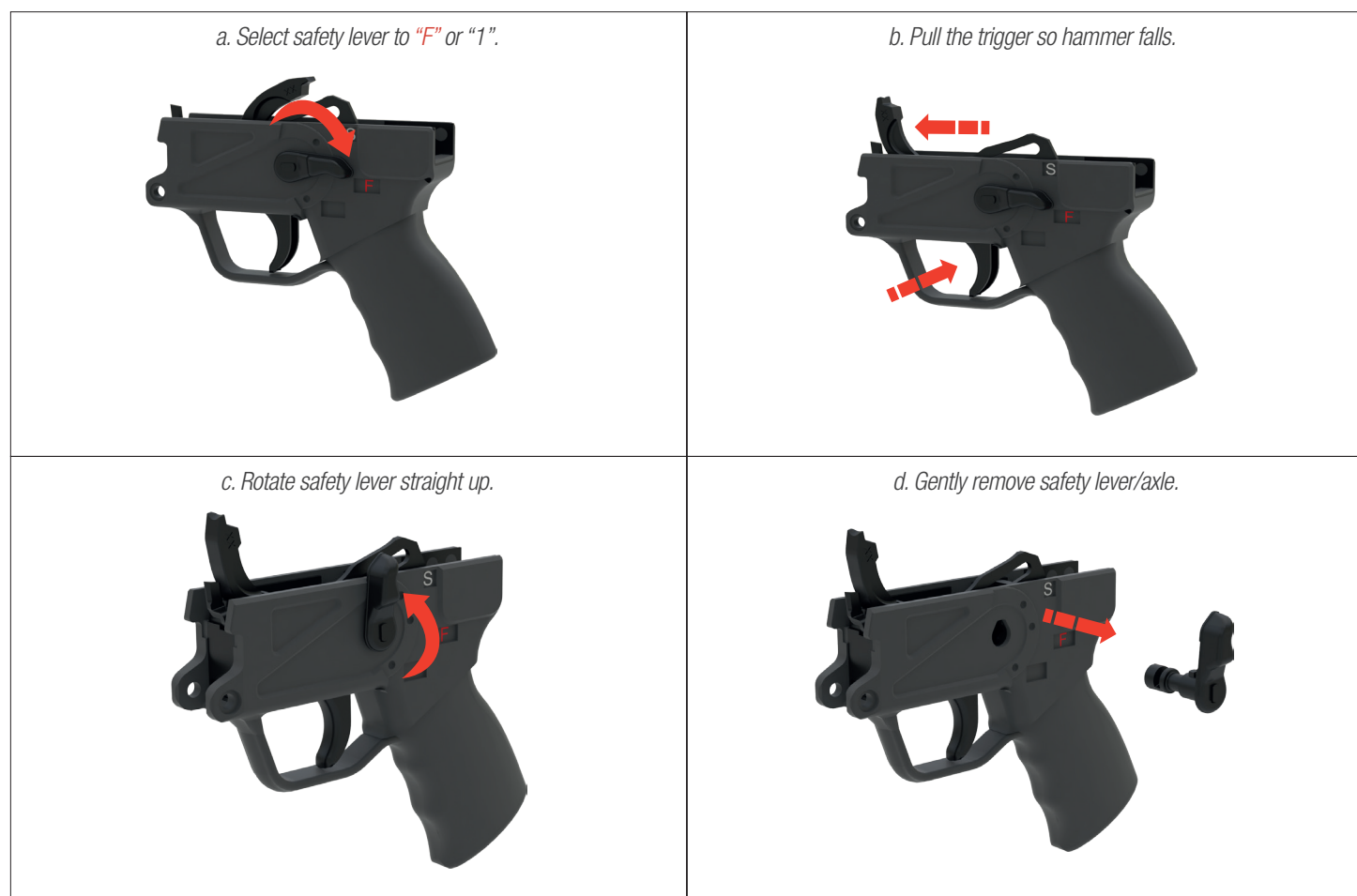

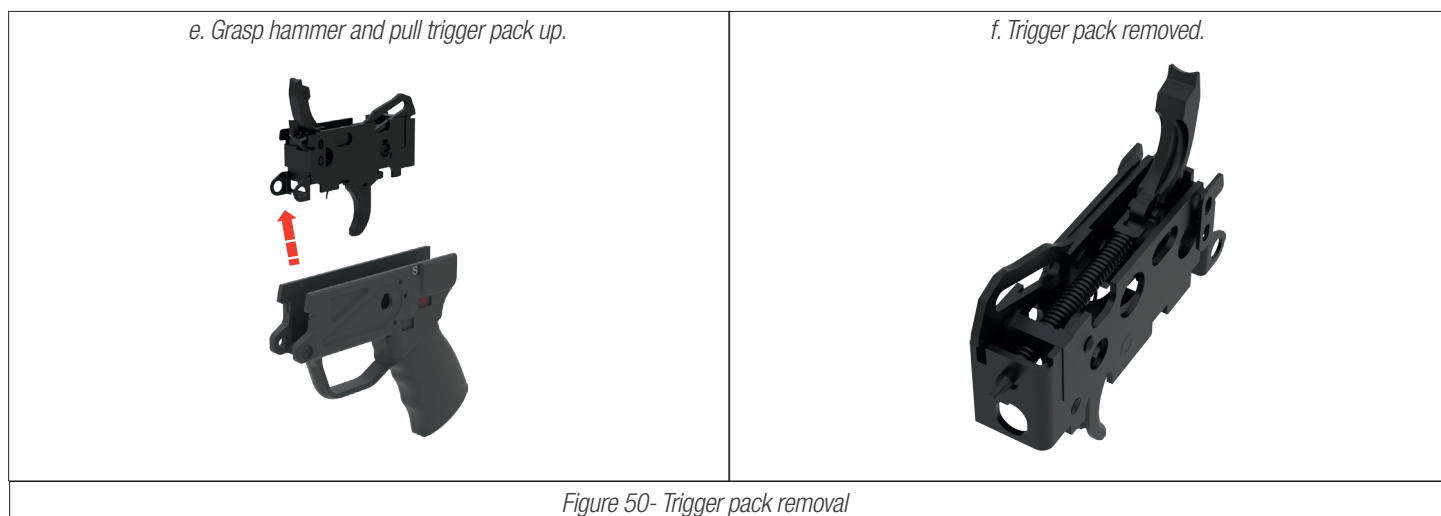

Select safety lever to "F" or "1" (see image a). Pull the trigger so hammer falls (see image b) using the offhand to prevent it from falling freely. Rotate safety lever straight up (see image c). Gently remove safety lever/axle (see image d). Grasp hammer and pull trigger pack up (see image e).

## Trigger Pack Maintenance

The trigger pack can be removed during regular cleaning. Once removed, inspect for dirt, sand, unburned powder, or any other debris. Any debris can be removed by brush or compressed air. It is recommended that a certified armorer initiate disassembly of the trigger pack.

# Z-43 RIFLE & Z-43P PISTOL SLING

## 3-Point Sling

The 3-point sling is designed to facilitate across-the-back carry and rapid deployment. The length of the sling is adjustable by way of the slide buckle.

The spring clip is attached to the front of the firearm and the flat hook clip is attached to the buttstock. Strap, Side 1 crosses the back and Strap, Side 2 two crosses the chest. The adjustable slide buckle is on the back. The sliding clip hooks into the holder on the left side of the magazine.

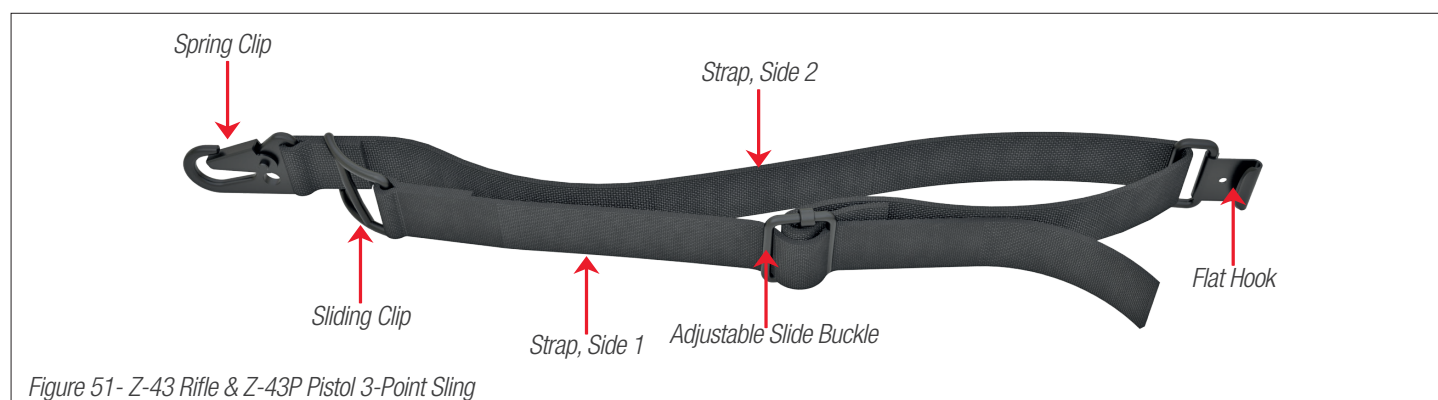





# TROUBLESHOOTING

NO.	ISSUE	PROBABLE CAUSE	CORRECTIVE ACTION
1	Failure to fire	Firing pin broken Firing pin tip worn Firing pin spring broken Faulty ammunition Bolt carrier not in battery Damage/obstruction in trigger pack	Replace firing pin Replace firing pin Replace firing pin spring Replace ammunition Recharge firearm Repair trigger pack
2	Failure to extract	Extractor broken Extractor spring broken Bolt face has obstruction	Replace extractor Replace extractor spring Clean bolt face
3	Failure to eject	Ejector broken	Replace ejector
4	Failure to feed	Magazine not fully seated Magazine catch not engaged Magazine lips deformed Obstruction of charging handle movement Faulty ammunition	Fully insert magazine until it locks Inspect magazine latch button and paddle Replace magazine Ensure charging handle moves freely Replace ammunition.
5	Failure to chamber	Bolt face has obstruction Obstruction in trunnion/chamber Faulty ammunition Weak recoil spring	Clean bolt face Clean trunnion/chamber Replace ammunition Replace recoil spring
6	Failure to go into battery	Obstruction in trunnion/chamber Faulty ammunition Damaged bolt assembly Bolt face has obstruction Weak recoil spring	Clean trunnion/chamber Replace ammunition Repair bolt assembly Clean bolt face Replace recoil spring



**CAUTION: IF ABOVE CORRECTIVE ACTIONS DO NOT REMEDY ISSUE, PLEASE SEEK ASSISTANCE FROM QUALIFIED GUNSMITH OR ARMORER BEFORE CONTACTING ZENITH FIREARMS.**



## Zenith Firearms

10517 Critzer Shop Road • Afton, VA 22920 • 434.202.7790

[info@zenithfirearms.com](mailto:info@zenithfirearms.com) • [www.zenithfirearms.com](http://www.zenithfirearms.com)