

SIG SAUER[®]
when it counts[®]



SIG MPX[™]

OWNERS MANUAL: HANDLING & SAFETY INSTRUCTIONS



READ THE INSTRUCTIONS AND WARNINGS IN THIS MANUAL CAREFULLY BEFORE USING THIS FIREARM; DO NOT DISCARD THIS MANUAL.

This instruction manual should always accompany this firearm and be transferred with it upon ownership, or when the firearm is loaned or presented to another person.

State-By-State Warnings

Certain states require, by law, that their own specified warning notices, in larger-than-normal type be conspicuously included by the manufacturer, distributor, or retail dealer with firearms sold in that state. SIG SAUER sells its products in compliance with applicable laws and regulations. Because our products may be sold in these states, we include the following:

CALIFORNIA: WARNING

"Children are attracted to and can operate firearms that can cause severe injuries or death. Prevent child access by always keeping guns locked away and unloaded when not in use. If you keep a loaded firearm where a child obtains and improperly uses it, you may be fined or sent to prison."

ADVERTENCIA

"A los niños atraen las armas de fuego y las pueden hacer funcionar. Ellos pueden causarse lesiones graves y la muerte. Evite que los niños tengan acceso a las armas de fuego guardándolas siempre con llave y descargadas cuando no las esté utilizando. Si usted tiene una arma de fuego cargada en un lugar en que un niño tiene acceso a ella y la usa indebidamente, le pueden dar una multa o enviarlo a la cárcel."

CONNECTICUT:

"UNLAWFUL STORAGE OF A LOADED FIREARM MAY RESULT IN IMPRISONMENT OR FINE."

FLORIDA:

"IT IS UNLAWFUL, AND PUNISHABLE BY IMPRISONMENT AND FINE, FOR ANY ADULT TO STORE OR LEAVE A FIREARM IN ANY PLACE WITHIN THE REACH OR EASY ACCESS OF A MINOR UNDER 18 YEARS OF AGE OR TO KNOWINGLY SELL OR OTHERWISE TRANSFER OWNERSHIP OR POSSESSION OF A FIREARM TO A MINOR OR A PERSON OF UNSOUND MIND."

MAINE:

"ENDANGERING THE WELFARE OF A CHILD IS A CRIME. IF YOU LEAVE A FIREARM AND AMMUNITION WITHIN EASY ACCESS OF A CHILD, YOU MAY BE SUBJECT TO FINE, IMPRISONMENT OR BOTH. KEEP FIREARMS AND AMMUNITION SEPARATE. KEEP FIREARMS AND AMMUNITION LOCKED UP. USE TRIGGER LOCKS."

MARYLAND:

"WARNING: Children can operate firearms which may cause death or serious injury. It is a crime to store or leave a loaded firearm in any location where an individual knew or should have known that an unsupervised minor would gain access to the firearm. Store your firearm responsibly!"

MASSACHUSETTS:

"WARNING FROM THE MASSACHUSETTS ATTORNEY GENERAL: This handgun is not equipped with a device that fully blocks use by unauthorized users. More than 200,000 firearms like this one are stolen from their owners every year in the United States. In addition, there are more than a thousand suicides each year by younger children and teenagers who get access to firearms. Hundreds more die from accidental discharge. It is likely that many more children sustain serious wounds, or inflict such wounds accidentally on others. In order to limit the chance of such misuse, it is imperative that you keep this weapon locked in a secure place and take other steps necessary to limit the possibility of theft or accident. Failure to take reasonable preventative steps may result in innocent lives being lost, and in some circumstances may result in your liability for these deaths."

"IT IS UNLAWFUL TO STORE OR KEEP A FIREARM, RIFLE, SHOTGUN OR MACHINE GUN IN ANY PLACE UNLESS THAT WEAPON IS EQUIPPED WITH A TAMPER RESISTANT SAFETY DEVICE OR IS STORED OR KEPT IN A SECURELY LOCKED CONTAINER."

NEW JERSEY:

"IT IS A CRIMINAL OFFENSE TO LEAVE A LOADED FIREARM WITHIN EASY ACCESS OF A MINOR."

NEW YORK CITY, NY:

“THE USE OF A LOCKING DEVICE OR SAFETY LOCK IS ONLY ONE ASPECT OF RESPONSIBLE FIREARMS STORAGE. FOR INCREASED SAFETY, FIREARMS SHOULD BE STORED UNLOADED AND LOCKED IN A LOCATION THAT IS BOTH SEPARATE FROM THEIR AMMUNITION AND INACCESSIBLE TO CHILDREN AND OTHER UNAUTHORIZED PERSONS.”

NORTH CAROLINA:

Any person who resides in the same premises as a minor, owns or possesses a firearm, and stores or leaves the firearm (i) in a condition that the firearm can be discharged and (ii) in a manner that the person knew or should have known that an unsupervised minor would be able to gain access to the firearm, is guilty of a Class 1 misdemeanor if a minor gains access to the firearm without the lawful permission of the minor’s parents or a person having charge of the minor and the minor:

- (1) Possesses it in violation of G.S. 14-269.2(b)
- (2) Exhibits it in a public place in a careless, angry, or threatening manner;
- (3) Causes personal injury or death with it not in self defense; or
- (4) Uses it in the commission of a crime.

TEXAS:

“IT IS UNLAWFUL TO STORE, TRANSPORT, OR ABANDON AN UNSECURED FIREARM IN A PLACE WHERE CHILDREN ARE LIKELY TO BE AND CAN OBTAIN ACCESS TO THE FIREARM.”

WISCONSIN:

“IF YOU LEAVE A LOADED FIREARM WITHIN THE REACH OR EASY ACCESS OF A CHILD YOU MAY BE FINED OR IMPRISONED OR BOTH IF THE CHILD IMPROPERLY DISCHARGES, POSSESSES, OR EXHIBITS THE FIREARM.”

Please check with your licensed retailer, state police, or local police for additional warnings, which may be required by local law or regulation. Such regulations change constantly, and local authorities are in the best position to advise you on such legal matters.

THE BASIC RULES OF SAFE FIREARMS HANDLING

1. ALWAYS treat every gun as if it were loaded.
2. ALWAYS be sure the barrel is clear of any obstruction.
3. ALWAYS be sure of your backstop, what lies beyond, and the safety of bystanders before you shoot.
4. ALWAYS use clean, dry, original factory-made ammunition of the proper type and caliber for your gun.
5. ALWAYS wear ear protection and safety glasses when shooting.
6. ALWAYS carry your gun so that you can control the direction of the muzzle if you fall or stumble.
7. NEVER shoot at a flat surface or water.
8. DO NOT leave an unattended gun loaded. Guns and ammunition should be stored separately, locked if possible, beyond the reach of children, careless adults, and unauthorized users.
9. NEVER allow your firearm to be used by anyone who has not read and understood this operator's manual.
10. DO NOT point any gun, loaded or unloaded, at any undesired target.
11. NEVER fire your rifle near an animal unless it is trained to accept the noise; an animal's startled reaction could injure it or cause an accident.
12. NEVER drink alcoholic beverages or take drugs before or during shooting, as your vision and judgment could be seriously impaired, making your gun handling unsafe.

WARNING – LOCKING DEVICES

This firearm was originally sold with a key- operated locking device. While it can help provide secure storage for your unloaded firearm, any locking device can fail. All guns are designed to fire if they are loaded and the trigger is pulled. Therefore, never install the locking device inside the trigger guard or in any way that makes it possible to pull the trigger! Do not leave the keys in the lock.

The ultimate responsibility for secure storage of any firearm must depend upon its owner and his or her individual circumstances. Firearms should be stored unloaded, in a secure location, separate from their ammunition.

NEVER INSTALL THE LOCKING DEVICE INSIDE THE TRIGGER GUARD

To maximize effectiveness and reduce the chances of malfunction or damage to a firearm, ALWAYS refer to the locking device's manufacturer directions for installation and removal of the device.

FIREARMS SAFETY IS YOUR RESPONSIBILITY

This owner's manual is designed to assist you in learning how to use and care for your SIG SAUER® rifle properly.

Only when you are certain that you fully understand this manual and can properly carry out its instructions, should you practice loading and firing your firearm with live ammunition. Having a gun in your possession is a full-time job; you cannot guess and you cannot forget. You must know how to use your firearm safely.

If you have any doubts about your ability to handle or use this firearm safely, you should seek supervised instruction. The Sig Sauer Academysm provides all levels of firearms safety and skill training, from beginner to expert. For more information contact:



www.sigsaueracademy.com • (603) 610-3400 • Epping, New Hampshire

**SAFETY MUST BE THE FIRST AND CONSTANT CONSIDERATION OF
EVERY PERSON WHO HANDLES FIREARMS AND AMMUNITION.**

For more information about safety, responsible firearms ownership, and shooting sports, contact:
National Rifle Association (NRA) of America, 11250 Waples Mill Road, Fairfax, VA 22030-7400
1-800-672-3888 • www.nra.com

TABLE OF CONTENTS

Topic	Page
State by State Warnings	2-5
Basic Rules of Safe Firearms Handling	5
Locking Device	6
General Safety Information and Mechanical Characteristics	14
1.0 Safety Information	14
1.1 Protect your Eyes and Ears	14
1.2 Ammunition	15-17
2.0 Mechanical Characteristics and Rifle Theory	19
2.1 Rifle Description	19
2.1.1 General	19
2.1.2 MPX-P and MPX-PSB Variants	19
2.1.3 Barrel with Receiver and Gas System	20
2.1.4 Carriage Assembly	21
2.1.5 KeyMod Handguard	22
2.1.6 Lower Receiver Assembly and Buttstock	23
2.1.7 Buttstock Operation	25
2.1.8 Buttstock Operation (left side folding)	26
2.1.9 Buttstock Operation (collapsible)	28
2.1.10 Removal of the Collapsible Buttstock	29
2.1.11 To Re-install the Collapsible Buttstock	30

Topic	Page
2.1.12 Recoil Pad Removal & Replacement (Folding & Collapsible)	31
2.1.13 Folding Adjustable Stock	32
2.1.14 Operation of Fire Control Selector (Safety)	33
2.1.15 Sights	36
2.1.16 Sight Deployment - Front Sight	37
2.1.17 Sight Deployment - Rear Sight	38
2.2 Magazines	39
2.3 Technical Specifications	40
3.0. Handling	41
3.1 Important Instructions	41
3.2 Loading the Magazine	42
3.3 Loading the Rifle	43
3.4 Reloading the Rifle after firing has commenced (partially loaded magazine in rifle)	44
3.5 Reloading the Rifle after firing has commenced (bolt locked open, empty magazine still in rifle)	45
4.0 Cycle of Operation	46
4.1 Firing	47
4.1.1 Unlocking of Bolt, Extraction & Ejection	48
4.1.2 Cocking of the Hammer	48
4.1.3 Chambering and Locking	48

Topic	Page
5.0 Unloading	49
6.0 Procedures in case of a Stoppage	50
6.1 Failure to Fire (Cold Rifle)	50
6.2 Failure to Fire (Hot Rifle)	51
6.3 Failure to Cycle	52
6.4 Feedway Stoppage (Jam)	53
7.0 Field Strip Disassembly	54
7.1 Detailed Disassembly of the Carriage Assembly to Upper Receiver	55
7.2 Extractor Removal	56
7.3 Handguard Removal	57
7.4 KeyMod Rail Segments	58
7.5 Removal of the Barrel	59
7.6 Removal of Gas Valve & Tappet	60
8.0 Cleaning	61
8.1 Cleaning the Bore	62
8.2 Cleaning the Chamber	62
8.3 Cleaning the Bolt	63
8.4 Cleaning the Bolt Carrier	63
8.5 Cleaning the Recoil Spring and Spring Rod Guides	63
8.6 Cleaning the Magazine	64
8.7 Cleaning the Gas Block, Piston and Valve	65

Topic	Page
9.0 Reassembly	66
9.1 Reassemble the Extractor to Bolt	66
9.2 Bolt Assembly to Bolt Carrier	66
9.3 Barrel Assembly Reattachment	69
9.4 Carriage Assembly to Upper Receiver	70
9.5 Handguard Reattachment	71
9.6 Rejoining Upper and lower Receivers	71
10.0 Perform a Function Check of the SIG MPX Semi-Automatic Rifle	72
10.1 Perform a Function Check (Auto)	73
11.0 Lubrication	74
12.0 Transportation and Storage	76
13.0 Service and Replacement Parts Policy	77
14.0 Shipping Firearms for Repair	79
15.0 Parts Diagram	82
SIG SAUER® Limited Lifetime Firearms Warranty	84

WARNINGS OF GREAT IMPORTANCE ARE FOUND WITHIN THIS MANUAL

Locking Devices	6	Firing	45
Alterations	13	Unloading	47
Ammunition	16, 19	Fire with Empty Mag	48
Lead Exposure	19	Clearing Jam	52
Manual Safety	25	Cam Pin	66
Handling - Firearm May Fire if Dropped	40	Storage	75
Loading	42	Parts Purchase	77
Do Not Load Hot Chamber	42, 50	Shipping	79

OTHER CAUTIONS AND WARNINGS APPEAR THROUGHOUT THE MANUAL

FIREARMS ARE DANGEROUS WEAPONS

**READ THE INSTRUCTIONS AND WARNINGS IN THIS MANUAL
THOROUGHLY AND CAREFULLY BEFORE USING.**

⚠ WARNING – ALTERATIONS

This product was designed to function properly in its original condition. Alterations can make it unsafe. Do not alter any part or add or substitute any parts or accessories not manufactured by SIG SAUER Inc. to be compatible for this product.

DO NOT ALTER ANY FIREARM

GENERAL SAFETY INFORMATION AND MECHANICAL CHARACTERISTICS

1.0 Safety Information

The safety warnings in this manual are important. By understanding the dangers inherent in the use of any firearm, and by taking the precautions described herein, you can enjoy increased safety in the use of your rifle. Failure to heed any of these warnings may result in serious injury to you or others, as well as severe damage to the firearm or other property. SIG SAUER Inc. shall not be responsible in any manner whatsoever for malfunctioning of the firearm, physical injury or property damage resulting in whole or in part from:

- 1) criminal or negligent discharge;
- 2) improper or careless handling;
- 3) unauthorized modifications;
- 4) defective, improper, hand-loaded, or reloaded ammunition;
- 5) corrosion;
- 6) neglect; or
- 7) other influences beyond our direct and immediate control.

This limitation applies regardless of whether liability is asserted on the basis of contract, negligence, or strict liability (including any failure to warn). Under no circumstance shall SIG SAUER Inc. be liable for incidental or consequential damages, such as loss of use of property, commercial loss, and loss of earnings or profits.

1.1 Protect Your Eyes And Ears

Always wear safety glasses and ear plugs or “ earmuff ” type protectors whenever you are shooting. Always make certain that persons close to you are similarly protected. Unprotected eyes may be injured by powder, gas, carbon residue, lubricant, metallic particles, or similar debris which may emanate occasionally from any firearm in normal use. Without ear protection, repeated exposure to shooting noise may lead to cumulative, permanent hearing loss.

1.2 Ammunition

1. Use only high quality, original, factory-manufactured ammunition. Do not use cartridges that are dirty, wet, corroded, bent, or damaged. Do not oil cartridges. Do not spray aerosol-type lubricants, preservative, or cleaners directly onto cartridges or where excess spray may flow into contact with cartridges. Lubricant or other foreign matter on cartridges can cause potentially dangerous ammunition malfunctions. Use only ammunition of the caliber for which your firearm is chambered. The SIG MPX is designed to operate with most commercially available high impulse ammunition. Should you encounter under-functioning of the SIG MPX, switch to a higher impulse cartridge and retry shooting the firearm.
2. The use of reloaded, “remanufactured” hand-loaded, or other non-standard ammunition voids all warranties. Reloading is a science and improperly loaded ammunition can be extremely dangerous. Severe damage to the firearm and serious injury to the shooter or to others may result. Always use ammunition that complies with the industry performance standards established by the Sporting Arms and Ammunition Manufacturers’ Institute, Inc. of the United States (SAAMI) or ammunition manufactured to military specifications.

WARNING – AMMUNITION (CARTRIDGE) NOTICE

SIG SAUER Inc. SPECIFICALLY DISCLAIMS RESPONSIBILITY FOR ANY DAMAGE OR INJURY WHATSOEVER OCCURRING IN CONNECTION WITH, OR AS A RESULT OF, THE USE IN ANY SIG SAUER FIREARM OF FAULTY, NON-STANDARD, “REMANUFACTURED” HAND LOADED (RELOADED) AMMUNITION, OR CARTRIDGES OTHER THAN THOSE FOR WHICH THE FIREARM WAS ORIGINALLY CHAMBERED.

3. Firearms may be severely damaged and serious injury to the shooter or to others may result from any condition causing excessive pressure inside the chamber or barrel during firing. Excessive pressure can be caused by obstructions in the barrel, propellant powder overloads, the use of incorrect cartridges, or defectively assembled cartridges. In addition, the use of a dirty, corroded, or damaged cartridge can lead to a burst cartridge case and consequent damage to the firearm and personal injury from the sudden escape of high-pressure propellant gas within the firearm's mechanism.

4. Immediately stop shooting and check the barrel for a possible obstruction whenever:

- You have difficulty in, or feel unusual resistance in, chambering a cartridge;
- A cartridge misfires (does not go off);
- The mechanism fails to extract a fired cartridge case;
- Unburned grains of propellant powder are discovered spilled in the mechanism;
- A shot sounds weak or abnormal. In such cases it is possible that a bullet is lodged part way down the barrel.
- Firing a subsequent bullet into the obstructed barrel can wreck the firearm and cause serious injury to the shooter or to bystanders.

5. Bullets can become lodged in the barrel:

- If the cartridge has been improperly loaded without propellant powder, or if the powder fails to ignite (ignition of the cartridge primer alone will push the bullet out of the cartridge case, but usually does not generate sufficient energy to expel the bullet completely from the barrel);
- If the bullet is not properly seated in the cartridge case. When such a cartridge is extracted from the chamber without being fired, the bullet may be left behind in the bore at the point where the rifling begins. Subsequent chambering of another cartridge may push the first bullet further into the bore.

6. If there is any reason to suspect that a bullet is obstructing the barrel, immediately unload the firearm and look through the bore. It is not sufficient to merely look in the chamber. A bullet may be lodged some distance down the barrel where it cannot easily be seen.

IF A BULLET IS IN THE BORE, DO NOT ATTEMPT TO SHOOT IT OUT BY USING ANOTHER CARTRIDGE OR BY BLOWING IT OUT WITH A BLANK OR ONE FROM WHICH THE BULLET HAS BEEN REMOVED. SUCH TECHNIQUES CAN GENERATE EXCESSIVE PRESSURE, WRECK THE FIREARM, AND CAUSE SERIOUS PERSONAL INJURY.

If the bullet can be removed with a cleaning rod, clean any unburned powder grains from the bore, chamber, and mechanism before resuming shooting. If the bullet cannot be dislodged by tapping it with a cleaning rod, take the firearm to a gunsmith.

7. Dirt, corrosion, or other foreign matter on a cartridge can impede complete chambering and may cause the cartridge case to burst upon firing. A damaged or deformed cartridge may also impede chambering performance and cause the cartridge case to burst upon firing.

8. Do not oil cartridges, and be sure to wipe the chamber clean of any oil or preservative before shooting. Oil interferes with the friction between cartridge case and chamber wall that is necessary for safe functioning, and subjects the firearm to stress similar to that imposed by excessive pressure.

9. Use lubricants sparingly on the moving parts of your firearm. Avoid excessive spraying of any aerosol gun care product, especially where it may get on ammunition. All lubricants and aerosol spray lubricants in particular can penetrate cartridge primers and cause misfires. Some highly penetrative lubricants can also migrate inside cartridge cases and cause deterioration of the propellant powder; on firing, the powder may not ignite. If only the primer ignites, there is danger that the bullet may become lodged in the barrel.

⚠️ WARNING – AMMUNITION



Death, serious injury, and damage can result from the use of wrong ammunition, bore obstructions, powder overloads, or incorrect cartridge components. Always wear shooting glasses and hearing protectors.

IMPROPER AMMUNITION DESTROYS FIREARMS

⚠️ WARNING – LEAD EXPOSURE



Discharging firearms in poorly ventilated areas, cleaning firearms, or handling ammunition may result in exposure to lead and other substances known to the state of California to cause birth defects, reproductive harm, and other serious physical injury. Maintain adequate ventilation at all times. Wash hands thoroughly after exposure.

SHOOTING OR CLEANING FIREARMS MAY EXPOSE YOU TO LEAD

2.0 Mechanical Characteristics and Rifle Theory

2.1 Rifle Description

2.1.1 General

The SIG MPX is a gas operated short stroke tappet system with a rotary bolt mechanism capable of semi-automatic and select fire (Auto) operation. Semi-automatic is defined as one round being fired each time the trigger is pressed to the rear until the magazine is depleted of ammunition. On "AUTO", once the trigger is pressed and held to the rear the MPX will continue to fire until either the operator releases the trigger or the magazine is depleted of ammunition. The SIG MPX may be chambered in either 9x19mm, .357 SIG, or .40 S&W.

2.1.2 MPX-P and MPX-PSB Variants

SIG SAUER offers the SIG MPX in two pistol configurations. The SIG MPX-P and the SIG MPX-PSB. The two pistols are identical in construction. The MPX-PSB however, is fitted with SIG SAUER'S Pistol Stabilizing Brace. The brace is attached to the Mil-Std 1913 rail of the lower receiver by means of a folding pistol brace tube.



All federal, state, and local laws apply to purchase and ownership of these two pistols. BATFE regulations apply to all modifications of the SIG MPX-P and the SIG MPX-PSB. Modifying the SIG MPX-P or the SIG MPX-PSB by attaching a rifle stock creates a short barreled rifle subject to the National Firearms Act (NFA), 26 U.S.C. 5845, which under penalty of law requires registration and tax payment.

2.1.3 Barrel with Receiver and Gas System

The barrel is mechanically mated to the receiver by means of two clamping screws. The barrel extension utilizes an indexing pin for alignment. A flash suppressor is screwed onto the muzzle end of the barrel. The gas block is fitted to the barrel and houses the gas valve and the tappet. The upper receiver has an integral Mil-Std 1913 accessory rail for attachment of sights or optics.

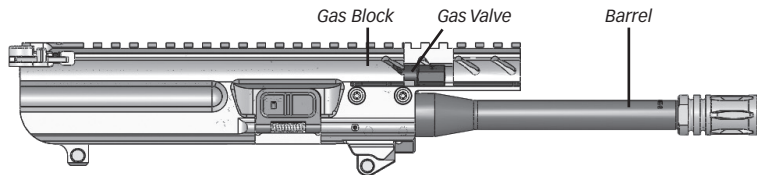

*BARREL WITH RECEIVER AND GAS SYSTEM
UPPER RECEIVER CUTAWAY FOR CLARITY*

2.1.4 Carriage Assembly

The carriage assembly guides the bolt and controls locking and unlocking by means of the cam pin. The carriage assembly also incorporates the op rod/recoil springs assembly, and firing pin. The bolt carrier is responsible for cocking the hammer.

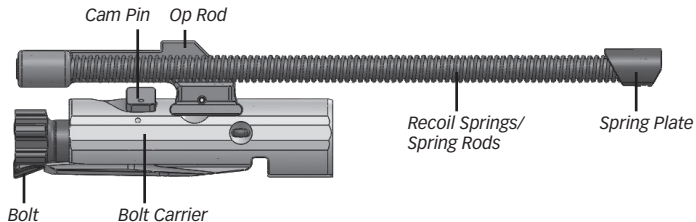

CARRIAGE ASSEMBLY

The bolt includes the firing pin, firing pin spring, and the extractor. The ejector slot is machined into the left side of the bolt. The bolt incorporates locking lugs that lock the bolt into the barrel extension. The cam pin passes into the bolt which produces rotation of the bolt for locking and unlocking and is retained in the bolt by the firing pin.

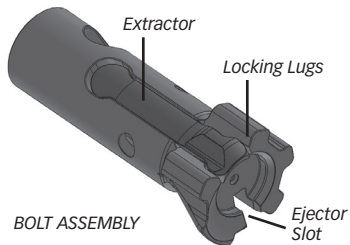

BOLT ASSEMBLY

2.1.5 KeyMod Handguard

The SIG MPX handguard protects the barrel and the gas system from damage and provides protection from barrel heat. The KeyMod feature provides attachment points for optional 2" and 4" Mil-Std 1913 accessory rails. These rails offer the ability to securely mount aiming, illumination devices, or other accessories to the handguard.

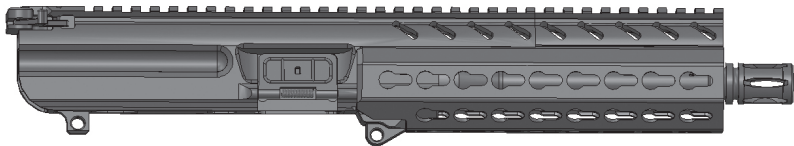

HANDGUARD ASSEMBLY ON MPX

2.1.6 Lower Receiver Assembly and Buttstock

The lower receiver assembly contains the fire control mechanism, bolt catch, magazine catch, bolt release, pistol grip, sling attachment points, and buttstock assembly. The fire control selector is ambidextrous along with the magazine catch. The fire control selector has two or three positions, SAFE-SEMI or SAFE-SEMI-AUTO (depending on model).

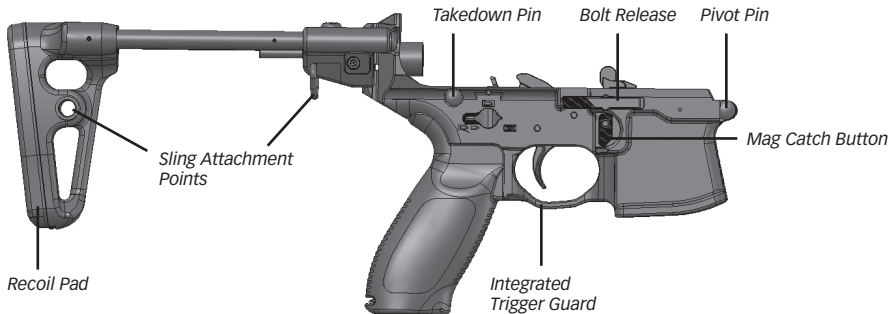

LOWER RECEIVER ASSEMBLY RIGHT SIDE

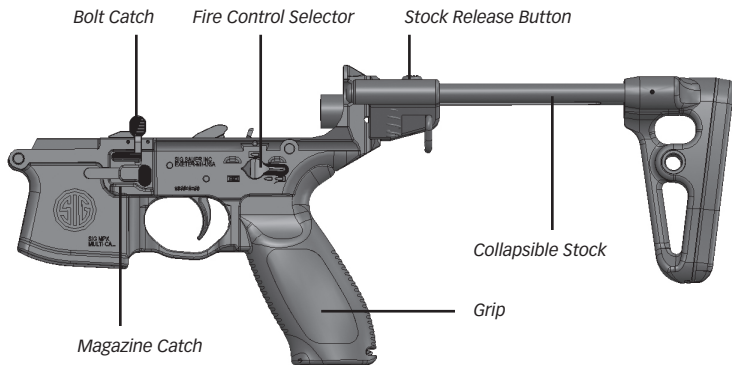

LOWER RECEIVER ASSEMBLY LEFT SIDE

2.1.7 Buttstock Operation

All SIG MPX folding stocks use the same type of hinge. The buttstock may vary depending on the model. To fold the stock, grasp the stock placing your thumb over the folding knuckle. Press down with your thumb while lifting up on the stock to dislocate it. This will allow the hinge to fold.

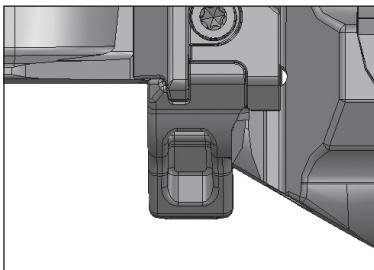

FOLDING HINGE

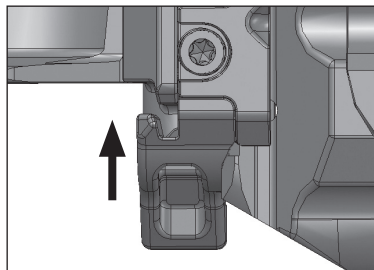

FOLDING HINGE DISLOCATED

2.1.8 Buttstock (Left Side Folding)

The buttstock on the SIG MPX may vary depending on the specific model you have. The left side folding stock is held in the folded position by the spring loaded stock adapter hinge which allows the stock to be folded.

⚠ WARNING – SAFETY

Before manipulating the weapon, ensure the safety lever is in the **“SAFE”** position. Keep muzzle pointed in a safe direction and finger out of the trigger guard.

To fold the stock, grasp the stock placing your thumb over the folding knuckle. Press down with your thumb while lifting up on the stock to dislocate it. This will allow the hinge to fold.

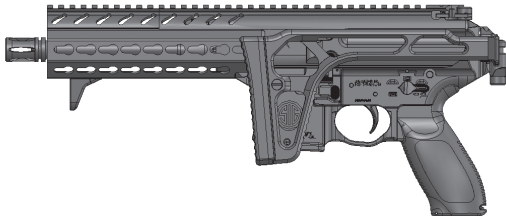

STOCK IN FOLDED POSITION

To Deploy the Buttstock (Left Side Folding)

⚠ WARNING – SAFETY

Before manipulating the weapon, ensure the safety lever is in the **“SAFE”** position. Keep muzzle pointed in a safe direction and finger out of the trigger guard.

While holding the MPX by the pistol grip with your right hand, grasp the metal portion of the buttstock with your left hand and pull sharply toward you until the stock locks in the open position.

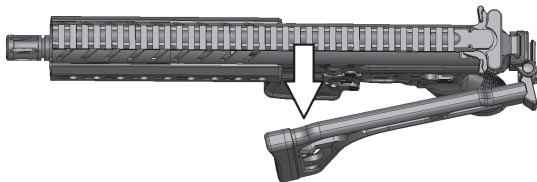

2.1.9 Buttstock Operation (Collapsible)

The SIG MPX Collapsible buttstock has three positions of adjustment. Fully extended, mid length collapsed, and fully collapsed. The length of pull can also be adjusted by the installation of either a 3/8" or 1.0" replaceable recoil pad.

⚠ WARNING – SAFETY

Before manipulating the weapon, ensure the safety lever is in the **"SAFE"** position. Keep muzzle pointed in a safe direction and finger out of the trigger guard.

To operate the stock depress the button on the top of the collapsible housing and move the buttstock to the desired location.

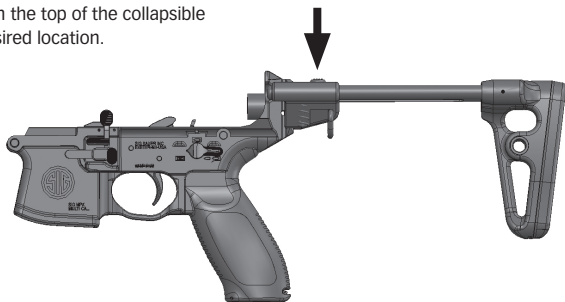

2.1.10 Removal of the Collapsible Buttstock

⚠ WARNING – SAFETY

Before manipulating the weapon, ensure the safety lever is in the **“SAFE”** position. Keep muzzle pointed in a safe direction and finger out of the trigger guard. Ensure the weapon is completely unloaded.

To remove the buttstock from the receiver, use a T-25 Torx wrench and loosen the clamp on the pivot housing. Remove the pivot housing from the Mil-Std 1913 rail interface at the rear of the lower receiver.



2.1.11 To Re-Install The Collapsible Buttstock

⚠ WARNING – SAFETY

Before manipulating the weapon, ensure the safety lever is in the **“SAFE”** position. Keep muzzle pointed in a safe direction and finger out of the trigger guard. Ensure the weapon is completely unloaded.

1. Align the housing with the Mil-Std 1913 rail interface on the lower receiver.
2. Slide the buttstock housing down onto the Mil-Std 1913 interface.
3. Using the T-25 Torx wrench tighten the clamp screw snug and then $\frac{1}{4}$ additional turn.



2.1.12 Recoil Pad Removal & Replacement (Folding & Collapsible)

⚠ WARNING – SAFETY

Before manipulating the weapon, ensure the safety lever is in the **“SAFE”** position. Keep muzzle pointed in a safe direction and finger out of the trigger guard.

1. Push inward on the release latch at the lower portion of the buttstock.
2. Slide the recoil pad downward and off of the buttstock.

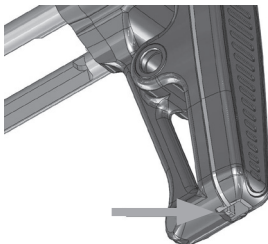

To replace the recoil pad:

1. Align the dovetail of the recoil pad with the slot on the buttstock.
2. Slide the recoil pad up until it latches into place.

2.1.13 Folding/Adjustable Stock

There are five positions of length adjustment on the stock to account for operators of varying stature and different gear that might be worn by the shooter. To adjust the length of the stock press in on the serrated stock key which will allow the latch to unlock. This will allow the stock to be moved to the desired position. The stock key is protected by the latch to keep the stock from inadvertently being unlatched during firing. Once the stock is at the desired length, release the stock key and manipulate the stock forward and backward to ensure it is securely engaged in the position closest to the desired length.

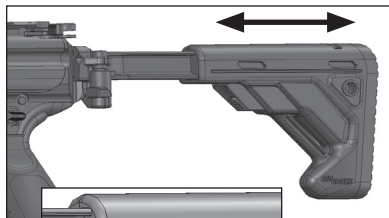

SERRATED
STOCK KEY

STOCK LATCH

2.1.14 Operation of Fire Control Selector Safety

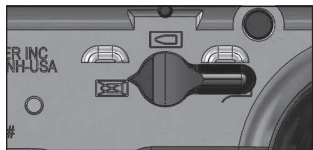

SAFE: MANUAL SAFETY "ON"

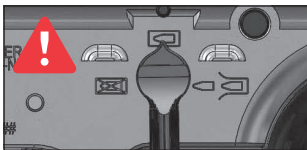

SEMI: MANUAL SAFETY "OFF"

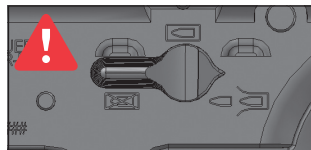

AUTO: MANUAL SAFETY "OFF"

FIRE CONTROL SELECTOR POSITION SAFE-SEMI-AUTO

⚠ WARNING – MANUAL SAFETY

Keep the safety "ON" unless actually firing. Always move the safety to its intended position and check it. The safety is not "ON" unless it is completely "ON." Never depend on a safety mechanism or any other mechanical device to justify careless handling or permitting the rifle to point in an unsafe direction. The only "SAFE" rifle is one in which the bolt is open, the chamber is empty, and there is no magazine in the gun.

KNOW HOW TO USE THE SAFETY

Four basic fundamentals of safe firearm handling should be applied during any and all activities described in this manual.

Treat every firearm as if it were loaded.

Always keep the muzzle pointed in a safe direction until ready to shoot.

Keep your finger off of the trigger and out of the trigger guard until ready to fire.

Be aware of your target and what is beyond it.

The SIG MPX is equipped with an ambidextrous fire control selector lever commonly referred to as a “safety lever” which can be manipulated from either the left or right side of the lower receiver. The selector has two (2) or three (3) positions depending on the model: SAFE and SEMI, or SAFE-SEMI-AUTO.

SAFE - Trigger is locked and rifle **CANNOT** be fired by pressing the trigger.

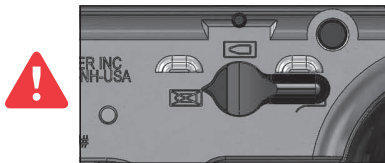

*FIRE CONTROL
SELECTOR ON SAFE*



SAFE: MANUAL SAFETY "ON"

SEMI – The trigger is no longer locked and the MPX **WILL FIRE** one shot with each press of the trigger until either the operator stops firing or the ammunition is expended from the magazine.

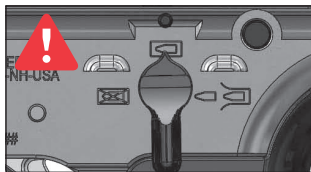

MANUAL SAFETY "OFF" - SEMI

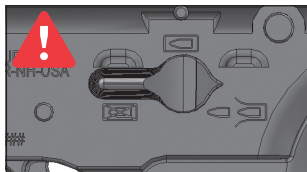

MANUAL SAFETY "OFF" - AUTO

AUTO (IF SO EQUIPPED) – When the fire control selector is rotated to AUTO, each press of the trigger will result in continuous firing at the cyclic rate until either the magazine is depleted of ammunition or the operator releases the trigger.

The fire control selector should always be in the "SAFE" position except when the operator is actually going to fire the rifle, and upon completion of firing.

2.1.15 Sights

The SIG MPX rifle features Mil-Std 1913 rails on the upper receiver and available optionally for the handguards. These rails may be used for attaching a variety of sighting systems, both optical and fixed. Some models feature SIG SAUER flip up front and rear sights as a standard feature. These sights are designed to provide a simple, durable sighting solution should you decide not to use an optical device. Markings on all rail surfaces give you a reference point to reattach your sighting system in exactly the same place if removal is needed for service.

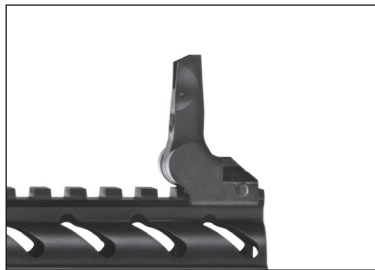
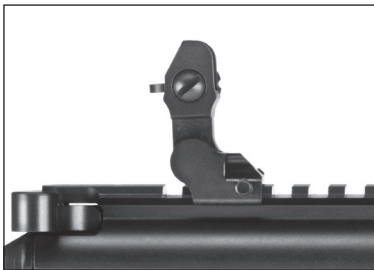

FRONT AND REAR SIGHTS

2.1.16 Sight Deployment - Front Sight

The SIG front sight will lock when raised to the up position.

⚠ WARNING – SAFETY

Before manipulating the weapon, ensure the safety lever is in the **“SAFE”** position. Keep muzzle pointed in a safe direction and finger out of the trigger guard.

To lower the front sight press in on the release button and fold the sight downward.

When zeroing the MPX with the flip up sights, you will make your elevation adjustments using the elevation wheel on the front sight.

Moving the front sight up will lower the point of impact of the shot.

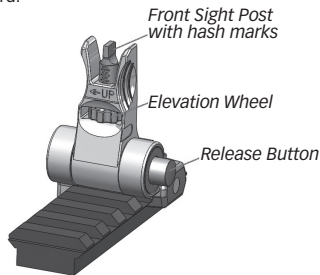

FRONT SIGHT POST DETAILING DETENT FOR ADJUSTMENT

2.1.17 Sight Deployment - Rear Sight

The SIG rear sight will lock when raised to the up position.

⚠ WARNING – SAFETY

Before manipulating the weapon, ensure the safety lever is in the **“SAFE”** position. Keep muzzle pointed in a safe direction and finger out of the trigger guard.

To lower the rear sight press in on the release button and fold the sight downward.

Windage adjustments are made by rotating the windage knob on the side of the rear sight. With the small aperture in the up position, vertical hash marks on the sight along with an indicating line on the large aperture will provide a reference for adjustment.

Move the rear sight aperture in the direction you want to move the impact of the shot.

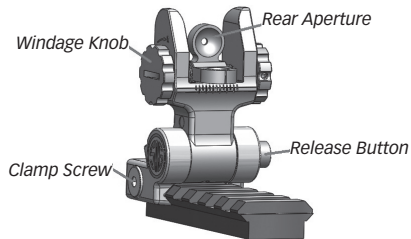

REAR SIGHT WINDAGE ADJUSTMENT

2.2 Magazines

The 10 and 20 round MPX magazines are the same length. The 10 round magazine has an insert to restrict it to 10 round capacity.

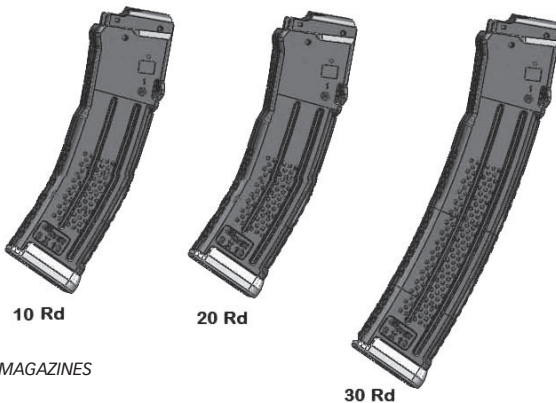

10, 20, AND 30 ROUND MAGAZINES

2.3 Technical Specifications

SPECIFICATION	MPX-K	MPX-P	MPX	16" CARBINE
CALIBER	9x19mm, .357SIG, .40S&W			
O.A.L. MIN/MAX	17.5"(444mm)/ 21.75" (552mm)	17.0" (432mm)	21.0" mm)/ 25.75"(654mm)	28.5"(724mm)/ 33.0"(838mm)
BARREL LENGTH	4.5"(114mm)	8.0"(203mm)	8.0"(203mm)	16.0"(406mm)
TWIST/GROOVE	1:10 (254mm) 6 groove			
WEIGHT W/O MAG	5.6 lbs (2.54kg)	5.0 lbs (2.27kg)	6.0 lbs (2.72kg)	7.2 lbs (3.27kg)
MAGAZINE	Ships with a 30 round magazine			
TRIGGER WEIGHT	5.5 (24.46N)-9.0 lbs (40.03N)			
SIGHT RADIUS	9.0" (229mm)	11.9" (302mm)	11.9" (302mm)	18.4" (467mm)
HEIGHT	10.4" (264m)			

*Specifications subject to change without notice.

3.0 Handling

3.1 Important Instructions

- Before manipulating the weapon, ensure the fire control lever is in the **“SAFE”** position.
- Use only factory-new ammunition which corresponds to the caliber of the weapon.
- During all manipulations of the rifle, point the weapon in a safe direction.
- Do not place your finger on the trigger until the target has been verified and you intend to shoot.
- Do not load the weapon until immediately before use.
- Unload weapon immediately after shooting is finished.
- Remove the magazine from the weapon prior to transportation.

⚠ WARNING – ANY FIREARM MAY FIRE IF DROPPED



Never carry the rifle loaded with the safety lever in the **“FIRE”** position. If dropped or struck with the safety off (**“FIRE”**), the rifle may fire. Such a discharge can occur with or without the trigger being directly struck or touched. Never rest a loaded rifle against any object (wall, tree, fence, vehicle, etc.) because there is always the possibility that the rifle will be jarred or slide from its position and fall with sufficient force to discharge. Keep the safety lever on **“SAFE”** unless actually firing.

3.2 Loading the Magazine

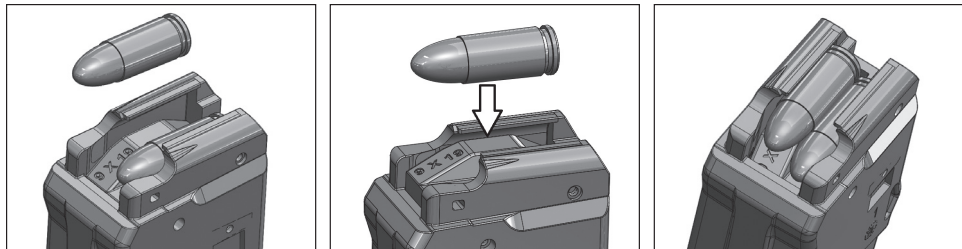

1. Ensure the magazine is the proper type and caliber for the rifle;
2. Place a round between the feed lips and press down ensuring the bullet is facing the front of the magazine;
3. Ensure the cartridges are fully seated to the rear of the magazine by tapping the back of the magazine in the palm of the hand. Load only the proper amount of ammunition the magazine is made for.

3.3 Loading the Rifle

⚠ **WARNING – SAFETY**

Before manipulating the weapon, ensure the safety lever is in the **“SAFE”** position. Keep muzzle pointed in a safe direction and finger out of the trigger guard.

1. Ensure the safety lever is in the **“SAFE”** position;
2. Insert the magazine and check that it is properly seated;
3. Bolt forward: Pull the charging handle back fully and release; or
4. Bolt locked open: Depress bolt catch fully to release bolt.

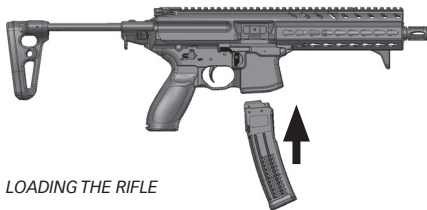

LOADING THE RIFLE

⚠ **WARNING – DO NOT LOAD HOT CHAMBER**

DO NOT LOAD A RIFLE WITH A HOT CHAMBER BECAUSE A ROUND MAY **“COOK”** OFF (i.e., a round may detonate (fire) unexpectedly just because it is exposed to the heat of the rifle’s chamber).

3.4 Reloading the Rifle after firing has commenced (partially loaded magazine still in rifle)

1. Place fire control selector on "SAFE".
2. Keep muzzle pointed in a safe direction and finger out of the trigger guard!
3. Depress magazine catch and remove magazine.

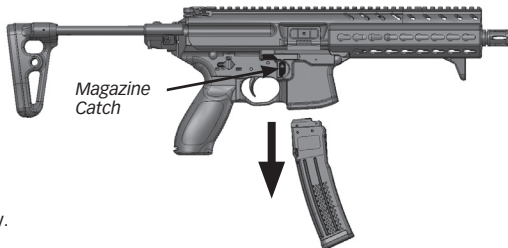
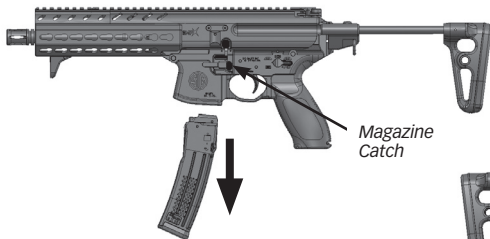

MAG CATCH BEING DEPRESSED LEFT AND RIGHT SIDE

4. Insert loaded magazine and ensure it is seated properly.

3.5 Reloading the Rifle after firing has commenced (bolt locked open, empty magazine still in rifle)

1. Place fire control selector on "SAFE".
2. Keep muzzle pointed in a safe direction and finger out of the trigger guard!
3. Depress magazine catch and remove magazine.
4. Insert loaded magazine and ensure it is seated properly.
5. Release the bolt by either:
 - a. Depressing bolt catch fully releasing the bolt;
 - b. Depressing the bolt release on the right side of the receiver; or
 - c. Grasping the charging handle, retracting it slightly and releasing it.

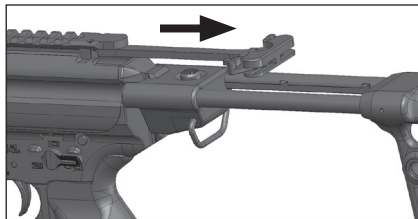

WHEN COMPLETING STEP 5.C ABOVE, RELEASE THE CHARGING HANDLE AND LET IT GO FORWARD UNDER FULL SPRING POWER. DO NOT RIDE THE CHARGING HANDLE FORWARD AS THIS MIGHT CAUSE A FAILURE OF THE CARTRIDGE TO FULLY SEAT INTO BATTERY.

4.0 Cycle of Operation

Ready to Fire Condition

The SIG MPX "Ready to Fire" condition is described as a loaded magazine properly seated into the magazine well, a live cartridge loaded into the chamber, the fire control selector place on "SAFE".

⚠ WARNING – FIRING

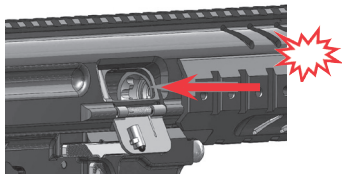

The bolt automatically opens and shuts quickly while firing. Keep face and hands away from it. Hot brass and powder gas is ejected quickly and can burn you. Always wear shooting glasses and hearing protectors.

BOLT OPENS FAST – HOT BRASS EJECTED

4.1 Firing

Semi-Auto Models (SAFE-SEMI)

Rotate the fire control selector from the **“SAFE”** position to the **“SEMI”** position. Pressing the trigger rearward will result in one round being fired. The shooter must release the trigger, allowing it to reset before another round can be fired.

Select Fire Models (SAFE-SEMI-AUTO)

Rotating the fire control selector from **“SAFE”** to **“AUTO”** or **“SEMI”** to **“AUTO”** will produce a continuous rate of fire beginning with the initial press of the trigger and continuing until either the magazine is depleted of ammunition or the operator releases the trigger, at which time the trigger resets. On **“AUTO”** releasing the trigger allows the hammer to be captured by the trigger sear and not the disconnect as it would be when in **“SEMI-AUTO”** mode. Pressing the trigger again will produce a continuous rate of fire until either the magazine is depleted of ammunition or the operator releases the trigger.

CAUTION – FIRING

THE SIG MPX IS A SEMI-AUTOMATIC RIFLE AND WILL AUTOMATICALLY RELOAD THE NEXT CARTRIDGE IN THE MAGAZINE AFTER THE CHAMBERED CARTRIDGE IS FIRED FOLLOWING ONE PRESS OF THE TRIGGER. THE RIFLE WILL NOW BE READY TO FIRE AGAIN ONCE THE TRIGGER IS RELEASED.

4.1.1 Unlocking of Bolt; Extraction & Ejection

1. The gas pressure generated by the burning powder in the cartridge propels the bullet through the bore of the barrel.
2. When the bullet passes the gas port in the barrel, a portion of the gas flows up into the gas block and into the gas valve.
3. The gas travels through the port in the gas valve and drives the piston rearward.
4. The piston then pushes the carriage assembly to the rear.
5. As the bolt carrier moves rearward, the cam pin allows the bolt to rotate to the right and unlock from the barrel extension.

4.1.2. Cocking of the Hammer

1. As the bolt carrier assembly continues rearward, the bottom surface of the bolt carrier cocks the hammer.
2. The hammer is then captured by the disconnect and held in place.

4.1.3 Chambering and Locking

1. Once the bolt carrier reaches its full rearward travel, the recoil springs force the bolt carrier assembly forward.
2. As the bolt carrier assembly moves forward, the next cartridge is stripped from the magazine and loaded into the chamber.
3. The bolt continues forward, rotates to the left, and locks into place.
4. The trigger is released and the hammer moves to its location of engagement with the trigger.
5. The rifle is now ready to be fired again.

5.0. Unloading

ALWAYS MAKE SURE THE MUZZLE IS POINTED IN A SAFE DIRECTION!

1. Ensure the fire control selector is rotated to the “SAFE” position.
2. Remove the magazine by depressing the magazine catch.
3. Retract the charging handle locking the carriage assembly to the rear.
4. Visually and physically inspect the chamber to verify there is no ammunition present.

Remember to clear the chamber after the magazine is removed. Never assume that any firearm is unloaded until you have personally checked it, visually and physically. After every range session, make sure the firearm is unloaded before you leave the range.

⚠ WARNING – RIFLE WILL FIRE WITH MAGAZINE EMPTY OR REMOVED

Removing cartridges from the magazine does not prevent the rifle from being fired! When there is a cartridge in the chamber and the safety lever is in the “FIRE” position, the cartridge will discharge if the trigger is pulled. It is absolutely essential for the user to know how to completely unload the rifle.

“Completely” means emptying the magazine and removing a chambered cartridge. The safety lever should always be in the “SAFE” position when the rifle is being unloaded.

THE RIFLE WILL FIRE EVEN IF THE MAGAZINE IS EMPTY OR REMOVED!

TO CLEAR A STOPPAGE (JAM)

6.0 Procedures In Case of a Stoppage

A “Stoppage” is an interruption in the cycle of operation as depicted in Section 4.0. A stoppage can normally be repaired by the operator by performing one of the following immediate actions described.

6.1 Failure to Fire (Cold Rifle)

Trigger is pressed, hammer falls, rifle does not fire

1. Ensure the safety lever is in the “SAFE” position.
2. Keep the muzzle pointed down range.
3. Ensure the magazine is properly seated in the magazine well by applying upward pressure and then pulling down on the magazine.
4. Retract the charging handle all the way back and observe the ejection of the expended case or a live cartridge; and
5. Visually inspect the chamber for any obstructions, if the chamber shows to be clear, release the charging handle to feed a new cartridge. Do NOT ride the charging handle forward.
6. Attempt to fire the rifle again.

6.2 Failure to Fire (Hot Rifle)

Trigger is pressed, hammer falls, the rifle does not fire

1. Keep the muzzle pointed down range, place the rifle on **“SAFE”**, remove the magazine, if you cannot extract the loaded cartridge within ten (10) seconds you must wait a minimum of 15 minutes before handling the rifle.
2. Upon completion of the 15 minutes, retract the charging handle all the way back and observe the ejection of the cartridge; and
3. Visually inspect the chamber for any obstructions, if the chamber shows to be clear, release the charging handle to feed a new cartridge. **DO NOT** ride the charging handle forward.
4. Attempt to fire the rifle again.

If the rifle does not fire after completing 6.1 or 6.2:

1. Unload, and clear the rifle.
2. Insert a fresh magazine;
3. Cycle the bolt assembly chambering a round; and
4. Attempt to fire the rifle.

If the rifle fails to fire after attempting all of the above, the rifle should be returned to SIG SAUER, Inc. for evaluation by a factory trained technician.

⚠ WARNING – UNINTENDED DISCHARGE FROM LOADING HOT CHAMBER

EXCESSIVE HEAT BUILD UP IN THE CHAMBER CAN CAUSE WHAT IS REFERRED TO AS A **“COOK OFF”**. THIS MEANS THE HEAT IN THE CHAMBER CAUSES THE POWDER TO IGNITE IN THE CHAMBERED CARTRIDGE. THE ROUND THEN DETONATES JUST AS IF IT WERE FIRED. IF THE RIFLE HAS BEEN FIRED FOR AN EXTENDED PERIOD OF TIME FOLLOW THE STEPS IN 6.2.

6.3 Failure to Cycle

⚠ WARNING – FAILURE TO CYCLE

ALWAYS ENSURE THE RIFLE IS UNLOADED AND CLEARED OF AMMUNITION.

If the SIG MPX fires one round but fails to cycle the action:

1. Place the fire control selector to **“SAFE”**
2. Remove the magazine; and
3. Lock the bolt carrier to the rear;
4. Ensure the chamber is clear (visual and physical check);
5. Reinsert a fresh magazine;
6. Release the bolt forward; and
7. Rotate the fire control selector to **“SEMI”** and attempt to fire the rifle.

6.4 Feedway Stoppage (Jam)

A feedway stoppage occurs when one or more rounds are trapped in the upper receiver and stop the cycle of operation. To clear this problem:

1. Place the MPX fire control selector on "SAFE" and keep the muzzle pointed in a safe direction.
2. Remove the magazine (you might have to pull downward with some force to remove the magazine from the magazine well due to the jammed cartridges).
3. Cycle the carriage assembly several times to clear any rounds from the receiver; and
4. Lock the carriage assembly to the rear, conduct a visual and physical inspection of the chamber to make sure the chamber has no obstructions; and
5. Insert a fresh magazine and continue to fire the rifle.

⚠ WARNING – UNLOAD

Always remove the source of ammunition (magazine) prior to attempting to clear a stoppage that requires retracting the charging handle/carriage assembly as unintentional release of the spring loaded carriage assembly could detonate live cartridges lodged in the upper receiver.

7.0. Field Strip Disassembly

1. Unload and clear the rifle per section 5.0.
2. Ensure the bolt carriage assembly is forward and the fire control selector is placed on **“SAFE”**.
3. Press the takedown pin from left to right until it stops (It is held into the lower receiver by a detent and will not pull free from the receiver).

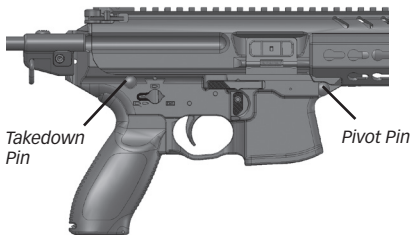

TAKEDOWN PIN AND PIVOT PIN

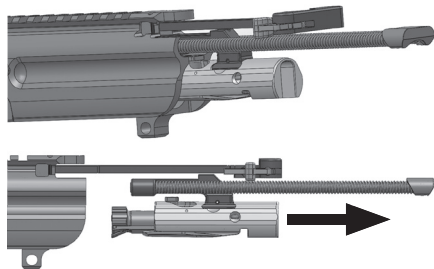

CARRIAGE ASSEMBLY

4. Press the Pivot Pin from left to right until it stops at the detent.
5. Separate the upper receiver from the lower receiver.
6. Grasp the charging handle and pull it rearward until it stops.
7. Remove the carriage assembly from the rear opening of the upper receiver.
8. Align the tabs of the charging handle and lift it from the receiver.

7.1. Detailed Disassembly of Carriage Assembly

1. Grasp the left side recoil spring and retract it while holding the spring housing.
2. Swing the spring plate away from the end of the spring rod.
3. Remove the spring from the spring rod.
4. Remove the spring rod from the op rod pulling it forward from the op rod (it is only necessary to remove the left side spring rod and recoil spring).
5. Remove firing pin retaining pin.
6. Remove firing pin and spring.
7. Rotate the cam pin 90° and lift out the cam pin and pull the bolt forward out of the bolt carrier.

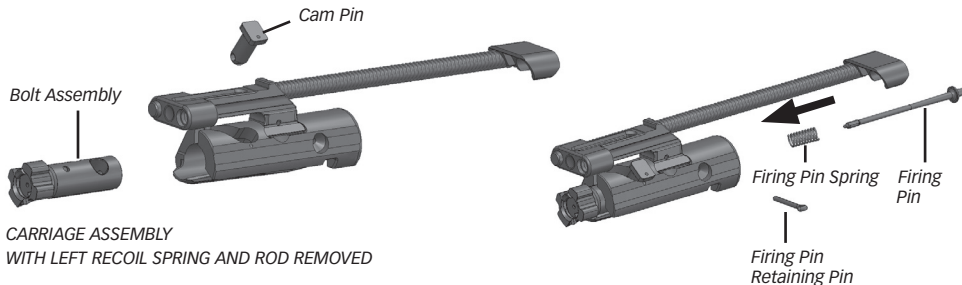

7.2 Extractor Removal

1. Apply slight pressure to the rear of the extractor with the thumb.
2. Using a punch, or the tip of the firing pin, push the extractor pin down and out of the bolt body.
3. Remove the extractor from the bolt.

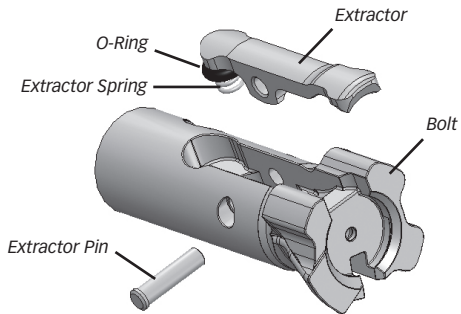

BOLT WITH EXTRACTOR REMOVED

NOTE: Only separate the extractor spring and O-ring from the extractor when replacement is necessary.

7.3 Handguard Removal

1. Unload and clear the rifle per section 5.0.
2. Slide the front pivot pin about half way across to free the handguard retainer.
3. Grasp the handguard and slide it forward and off of the MPX upper receiver.

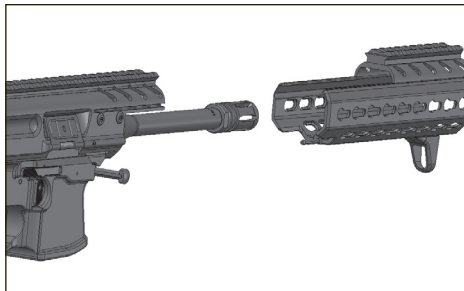

7.4 KeyMod Rail Segments

The SIG MPX handguard is designed with KeyMod attachment points on the 3, 6, and 9 clock positions. The KeyMod system offers the ability to mount accessories such as lights, laser aiming devices, slings, bipods, etc, in accordance with user requirements.

The MPX Mil-Std 1913 Accessory Rails come pre-assembled with the screws and KeyMod nuts fixed.

To remove the Mil-Std 1913 rail segment:

1. Loosen the two attaching screws with a T-15 Torx wrench.
2. Slightly lift the rail so the round posts are clear of the holes of the handguard.
3. Slide the rail rearward until it can be lifted from the handguard.

To attach the Mil-Std 1913 rail segment:

4. Loosen the two attaching screws with a T-15 Torx wrench.
5. Align the accessory rail assembly (A) to the desired location on the handguard with the taper of the KeyMod nuts (C) facing the muzzle as shown in the image below.
6. Insert the rail to the handguard by sliding the nuts into the KeyMod slots in the handguard. Slide the rail forward until the round posts (B) of the rail can be pushed into the corresponding holes in the handguard.
7. Hold the rail to the handguard as you tighten the screws by hand until snug. DO NOT OVERTIGHTEN.

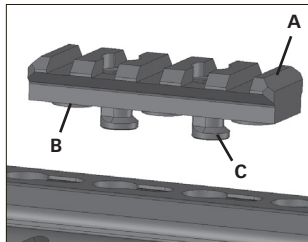

7.5 Removal of the Barrel

1. Unload and clear the rifle per section 5.0.
2. Using a T-25 Torx wrench, remove the two barrel retention screws from the right side of the upper receiver.
3. Remove the two barrel screw nuts from the left side of the upper receiver.
Tip! If the nuts will not fall out of the receiver take one of the retention screws and thread it into the nut from the left side 2-3 turns then use the screw to pull the nut out of the receiver.
4. Grasp the barrel and pull it straight out of the upper receiver.

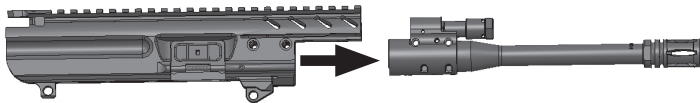
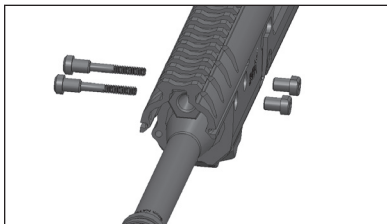
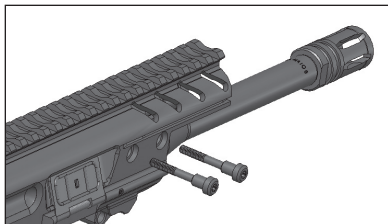

7.6 Removal of Gas Valve & Tappet

You must first remove the barrel to access the gas valve and tappet.

Extensive use prior to cleaning might require the operator to oil the valve flange to aid in removal due to carbon build up.

1. Unload and clear the rifle per section 5.0.
2. Install a punch through one of the holes and rotate the valve until the flange is free and clear of the gas block.
3. Pull the valve out of the gas block.
4. Push the tappet out of the gas block.

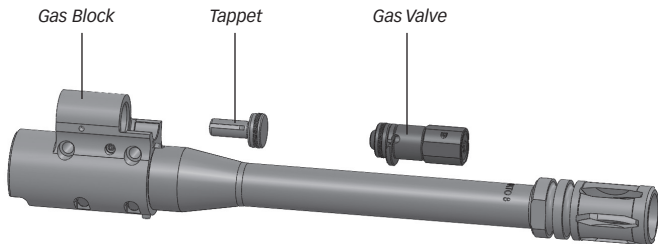

8.0 Cleaning

1. Your rifle is delivered factory packaged and preserved with a light coating of protective grease and oils. Before loading make certain that all packing grease and oil has been cleaned from the bore and exposed mechanism.
2. Before you begin to disassemble your firearm for cleaning, always double-check to make sure it is unloaded!
3. After cleaning, always check to be sure that no cleaning patch or other obstruction remains in the bore or chamber!

ONLY USE CLEANING AND LUBRICATION PRODUCTS THAT ARE SPECIFICALLY DESIGNED FOR USE ON FIREARMS.

DO NOT USE WIRE BRUSHES ON ALUMINUM SURFACES SUCH AS THE RECEIVERS OR QUAD RAILS AS THIS MAY SCRATCH THE FINISH.

READ ALL WARNING LABELS AND OBTAIN MATERIAL SAFETY DATA SHEETS ON ANY CLEANING, LUBRICATION, AND PROTECTIVE CHEMICALS USED.

CLEANER, LUBRICANT, PROTECTANT IS COMMONLY REFERRED TO AS "CLP".

SOME BORE CLEANERS ARE NOT MEANT TO BE LEFT IN THE BORE FOR EXTENDED PERIOD OF TIME.

FOLLOW ALL MANUFACTURER'S INSTRUCTIONS AND CAUTIONS WHEN USING CLEANING OR LUBRICATION PRODUCTS ON FIREARMS.

SOLVENT IS A GENERIC TERM AND WILL BE USED TO DESCRIBE A GENERAL BORE CLEANING SOLUTION.

8.1 Cleaning the Bore

1. Run a patch soaked in solvent through the bore.
2. Allow the solvent to soak in the barrel for at least 5 minutes.
3. Move on to section 8.3 and clean the bolt while the solvent works on loosening the residue in the bore of the barrel.
4. If the barrel is heavily fouled, use a cleaning rod and a brass or nylon bore brush, of the proper bore diameter, to clean the bore from the chamber end to the muzzle end. Pass the brush completely out past the muzzle and do not change direction in the bore as the brush can become stuck in the bore.
5. Run cotton patches through the bore until the patches come out clean. The bore and chamber of the barrel may be lightly lubricated with an oily patch if the rifle is to be stored. Upon returning the rifle to service you must remove the oil by running a dry patch through the barrel.

8.2 Cleaning the Chamber

Keep muzzle pointed upward to keep chamber residue from running down into the cleaned bore.

1. Use a chamber brush coated in solvent to clean chamber.
2. Use a minimum of five (5) plunge strokes and three (3) 360 degree clockwise rotations.
3. Clean residue with cotton patches, swabs, or a chamber mop.

8.3 Cleaning the Bolt

A cotton patch or a soft toothbrush and solvent can be used to complete the following steps:

1. Clean all fouling from around the bolt locking lugs.
2. Clean all fouling from bolt body.
3. Use a pipe cleaner to clean firing pin channel.

8.4 Cleaning the Bolt Carrier

1. Clean all fouling from bolt carrier body.
2. Clean the ejector channel in the carrier with a brush or cotton swabs.

8.5 Cleaning the Recoil Springs Spring Rods

1. Clean with rag and solvent.
2. Wipe dry.

8.6 Cleaning the Magazine

Magazines should be cleaned whenever the rifle is cleaned as preventive maintenance. NOTE: Does not apply to 10 round magazine which cannot be disassembled for cleaning.

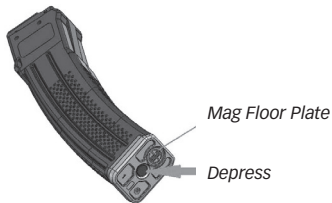

FLOOR PLATE REMOVAL

Push in on the stud of the lower spring guide in the center of the magazine floorplate. Slide the magazine floor plate rearward off the magazine body. Remove the magazine spring and follower.

1. Use a brush to clean inside the body.
2. Clean the magazine body with a rag and CLP then wipe dry.
3. Clean follower and dry completely.

The magazine body should be kept dry. Any oil or solvent left behind will attract dirt and debris causing undue wear and possibly feeding issues. A very light coat of oil can be applied to the metal feed lips and mag catch stop of the magazine to prevent corrosion.

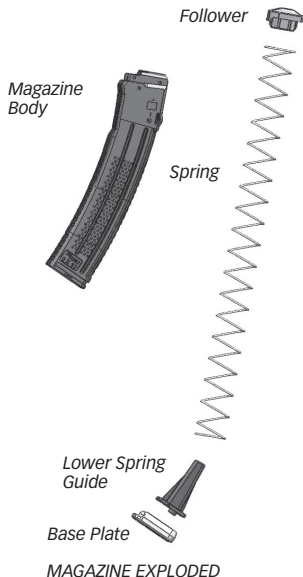

8.7 Cleaning the Gas Block, Gas Piston and Gas Valve

1. Clean carbon residue with rag and solvent.
2. Wipe dry.
3. Valve should rotate freely in gas block.

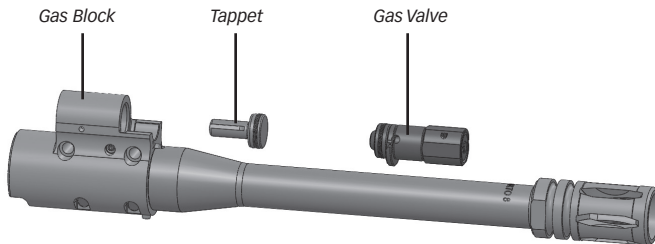

9.0 Reassembly

9.1 Reassemble the Extractor to the Bolt

1. Place the extractor in the slot of the bolt body.
2. Install the extractor retaining pin up and into the bolt body.

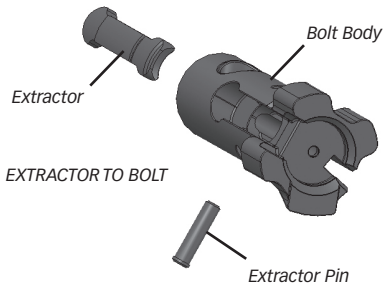

9.2 Bolt Assembly to Bolt Carrier

1. Slide the bolt into the bolt carrier with the extractor oriented to the right side of the carrier.
2. Insert the cam pin down into the bolt carrier and through the bolt.
3. Align the cam pin indent mark with the indent mark on the bolt carrier.

*BOLT TO
BOLT CARRIER*

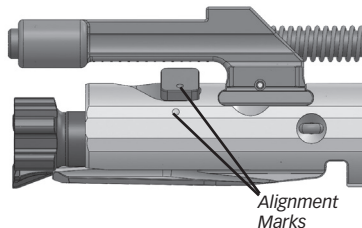
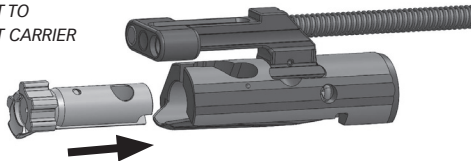

⚠ WARNING – ASSEMBLY

The Bolt Cam Pin Must Be Installed Or The Rifle Will Suffer A Catastrophic Failure Which Could Result In Serious Injury Or Death To The Operator.

Do Not Interchange Bolt Assemblies From One Rifle To Another. Doing So Could Result In Serious Injury Or Death To The Operator.

4. Slide the firing pin spring onto the firing pin.
5. Insert the firing pin and spring into the back of the bolt.

*INSTALL FIRING PIN AND FIRING
PIN RETAINING PIN*

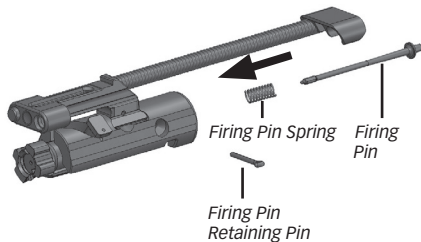

6. Push in on the firing pin and insert the firing pin retaining pin in from the left side of the bolt carrier. Check to make sure the firing pin is held in place.
7. Slide the recoil spring rod back through the op rod.
8. Slide the recoil spring over the spring rod.
9. Compress the recoil spring and swing the spring plate down over the end of the spring rod until it engages the recess in the spring plate.
10. Slowly release the spring pressure. Repeat for opposite side if removed.

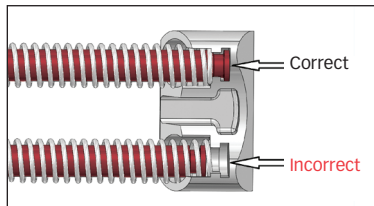
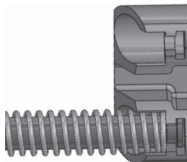
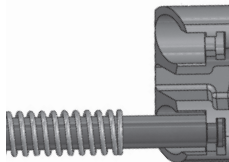

⚠ CAUTION – ASSEMBLY

IMPROPER INSTALLATION OF THE RECOIL SPRINGS AND/OR SPRING ROD WILL RESULT IN DAMAGE TO THE WEAPON. REFER TO IMAGES ABOVE FOR PROPER INSTALLATION OF THE SPRING ROD INTO THE SPRING PLATE.

9.3 Barrel Assembly Reattachment

1. Re-Install the gas valve if it has been removed.
2. Slide the barrel back into the opening of the upper receiver with the index pin at the 6 o'clock position.
3. Insert the two retaining nuts into the right side of the upper receiver with the index flats at the 12 o'clock position.
4. Install the two barrel retaining screws in through the left side of the receiver as shown.
5. Using a T-25 Torx bit, tighten the screws hand tight, then to 40 lbs- inch using an inch pound torque wrench.

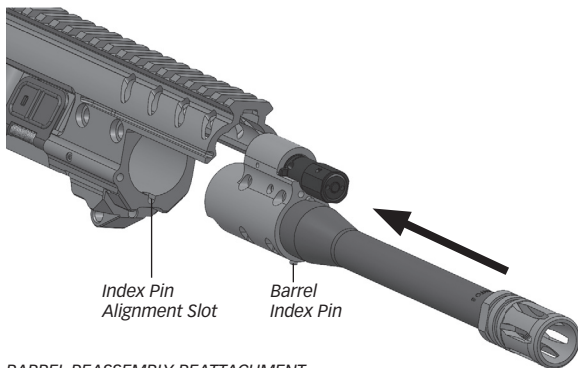

BARREL REASSEMBLY REATTACHMENT

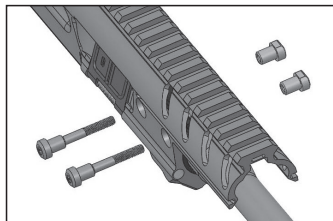

9.4 Carriage Assembly To Upper Receiver

1. Insert the charging handle into the slotted key way of the receiver and push it forward slightly.
2. Take the carriage assembly with the bolt pulled completely forward (unlocked position) and guide the op rod back into the upper receiver.
3. Simultaneously push the carriage assembly and the charging handle forward until the bolt and the charging handle lock into place.

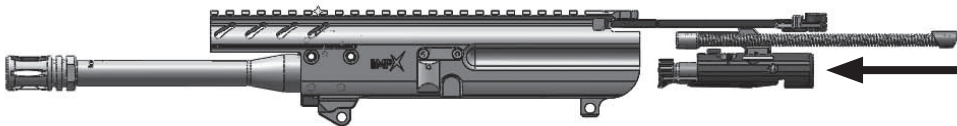

CARRIAGE ASSEMBLY TO UPPER

9.5 Handguard Reattachment

Align the rails of the handguard with the slots on the upper receiver and slide the handguard.

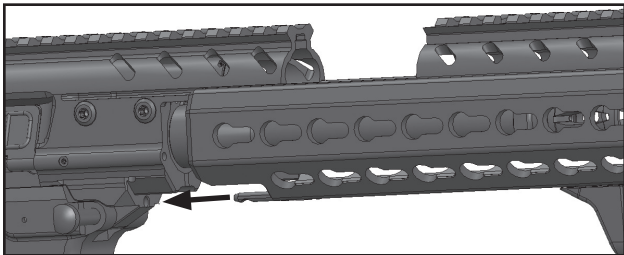

9.6 Rejoining Upper And Lower Receivers

To aid in steps 1-3, manually cock the hammer by pushing it down until it is held in place then rotate the fire control selector to **"SAFE"**.

1. Position the upper and lower receivers to align the pivot pin (front pin) holes.
2. Push the pivot pin from right to left until the head of the pivot pin is flush against the receiver. You will feel it captured by the detent pin.
3. Close the receivers together and push the takedown pin (rear pin) from right to left until the head of the takedown pin is flush against the receiver. You will feel it captured by the detent pin, as you did the pivot pin.

10.0 Perform a Function Check of the SIG MPX Semi-Automatic Rifle

With the SIG MPX and one UNLOADED magazine perform a function check of the rifle as outlined below in steps 1-13.

THE FUNCTION CHECK SHOULD ALWAYS BE DONE AFTER CLEANING AND ASSEMBLING THE RIFLE.

ALWAYS VISUALLY AND PHYSICALLY CLEAR THE FIREARM FIRST!

SIG MPX (SAFE/SEMI ONLY)

1. Insert an empty magazine into the magazine well until it locks into place.
2. Pull down on the magazine to ensure it is locked in place by the magazine catch.
3. Pull charging handle fully back then push it forward into locked position. The bolt carrier should now be held to the rear by the bolt catch.
4. Depress the magazine catch .
5. The magazine should fall free of the rifle under its own weight (unloaded).
6. Push the top of bolt catch on the left side of the lower receiver, or the bolt release on the right side to release the carriage assembly. The carriage assembly will travel forward into the locked position.
7. Rotate the fire control selector to **"SAFE"**.
8. Press the trigger to the rear. The hammer should not fall.
9. Rotate the fire control selector to **"SEMI"**.
10. Press the trigger to the rear and do not release it. You should hear a loud click as the hammer falls. Keep the trigger pressed to the rear; and
11. Pull the charging handle to the rear and release it while keeping trigger pulled. Hammer should not fall but be held in the cocked position by the disconnect.
12. Release the trigger. A click should be heard as the hammer is caught by the trigger sear.
13. Press the trigger to the rear again and the hammer should fall.

10.1 Perform a Function Check (Auto)

Upon completing the Semi-Auto Check on the previous page, conduct the following:

14. Set fire control to **"AUTO"**.
15. Pull and release charging handle.
16. Pull trigger. You should hear a loud click as hammer falls. Keep trigger pulled.
17. Keep trigger pulled. Pull charging handle back and ease it slowly but fully forward. A loud click should be heard at the end of its travel.
18. Release trigger. No click should be heard.
19. Pull trigger. No click should be heard.
20. Release trigger.

11.0 Lubrication

⚠ WARNING – SAFETY

Before manipulating the weapon, ensure the safety lever is in the “SAFE” position. Keep muzzle pointed in a safe direction and finger out of the trigger guard.

Using lubricant designed for use on firearms, lightly apply to the contact areas of the following components:

Upper Receiver Assembly

- Ejection port cover spring and latch.
- Charging handle latch and spring.
- Front sight detent.
- Rear sight windage screw and detent.
- Gas valve body.
- Recoil springs and spring rods.

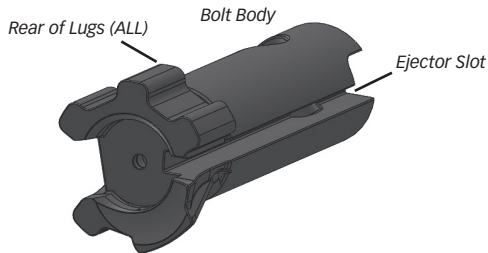

Carriage Assembly

- Extractor spring.
- Cam Pin.
- Locking lugs.
- Rail Surfaces, top and bottom.
- Bolt bearing surface.
- Spring housing and op rod.
- Bolt bearing surface.
- Ejector slot in bolt.
- Recoil springs and spring rods.

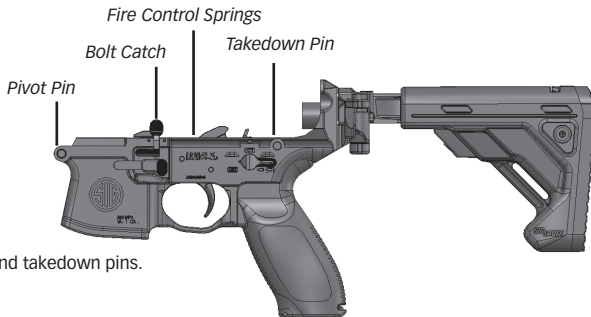
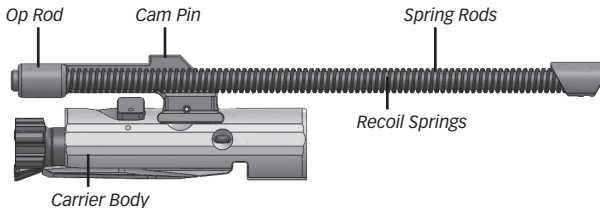

Lower Receiver Assembly

- Fire control springs, pins, detents, pivot and takedown pins.
- Trigger Sear Surface, Disconnect Surface.

12.0 Transportation and Storage

When transporting your firearm to and from shooting activities, keep it unloaded for your safety and for the safety of others. When storing your firearm, keep it separated from ammunition, under lock and key if possible, and out of the reach of children and other inexperienced or unauthorized persons.

WARNING – STORAGE

Never place or store any firearm in such a manner that it may be dislodged. Firearms should always be stored securely and unloaded, away from children and other unauthorized users. Use the locking device originally supplied with this firearm for storage. The use of a locking device or safety lock is only one aspect of responsible firearms storage. For increased safety, firearms should be stored unloaded and locked in a location that is both separate from their ammunition and inaccessible to children and any other unauthorized person.

STORE SECURELY & UNLOADED

13.0. Service and Replacement Parts Policy

Parts Policy

Our Service Department maintains a full complement of replacement parts. Even though most gunsmiths have the knowledge, training, and the ability to make necessary repairs to your firearm, the skill and workmanship of any particular 3rd party gunsmith is totally beyond our control. A limited number of parts are available for purchase and replacement by the end user without voiding the warranty of the firearm.

Should your firearm ever require service, we strongly recommend that you return it to SIG SAUER Inc. A firearm is a precision instrument and some replacement parts will require individual fitting to ensure correct operation. A wrong part, improper fitting, or incorrect mechanical adjustment may result in an unsafe condition or dangerous malfunction, damage to the firearm, or cause possible serious injury to the shooter or others.

IF ANY PART IS ORDERED WITHOUT RETURNING THE FIREARM TO SIG SAUER Inc., the customer bears full responsibility for ensuring that the part supplied is correct for their particular firearm and is properly installed and fitted by a qualified gunsmith.

SIG SAUER Inc. IS NOT RESPONSIBLE FOR THE FUNCTIONING OF ANY FIREARM IN WHICH REPLACEMENT PARTS ARE INSTALLED BY OTHERS.

⚠ WARNING – PARTS PURCHASE

It is the purchaser's responsibility to be absolutely certain that any parts ordered from the factory are correctly fitted and installed. Firearms are complicated mechanisms and IMPROPER FITTING OF PARTS MAY RESULT IN A DANGEROUS MALFUNCTION, DAMAGE TO THE FIREARM, AND SERIOUS INJURY TO THE SHOOTER AND OTHER PERSONS. The purchaser and installer of parts must accept full responsibility for the correct adjustment and functioning of the rifle after such installation. SIG SAUER offers a limited number of parts that can be purchased and installed by the end user without voiding the warranty of the firearm.

PARTS MUST FIT CORRECTLY

Service Policy

If you have questions concerning the performance or servicing of your rifle, please write or call:

SIG SAUER Inc.

Attention: Customer Service

72 Pease Boulevard, Newington, NH 03801

Phone: (603) 610-3000 ext. 1

Fax: (603) 766-7002

IF YOU DO NOT UNDERSTAND THE INSTRUCTIONS FOR OPERATING YOUR RIFLE, IT IS YOUR RESPONSIBILITY TO CALL OUR CUSTOMER SERVICE DEPARTMENT AT (603) 610-3000 EXT. 1 BEFORE USING YOUR RIFLE.

14.0. Shipping Firearms for Repair

Returning Your Firearm For Service

In the event you need to return your rifle to the SIG SAUER Service Department, here's what to do:

1. The first step is to contact Customer Service at (603) 610-3000 ext. 1 for an RMA number. This number allows SIG SAUER to track the status of your return from its receipt at SIG SAUER through its return to you. Please do not send your firearm until you obtain an RMA number.
2. Make sure that the chamber and magazine(s) are unloaded and that no ammunition is included with your returned firearm.
3. Package the firearm securely to prevent damage. Enclose a letter which includes your name, street address, daytime phone number, model and serial number, and a detailed description of the problem you have experienced or the work you want performed. With the exception of extra magazines, do not include scopes, mounts, or other accessories.
4. An individual's ability to legally ship firearms to the manufacturer for repair or service varies according to state and local law. Some jurisdictions require that firearms be shipped and returned by a Federally Licensed Firearms Dealer. Consult applicable law to determine how your firearm should be returned.
5. Federal law prohibits persons who do not possess a Federal Firearms License from shipping a firearm via the U.S. Postal Service. (Note: any shipment of firearms outside U.S. borders is subject to the export laws of the United States and to the valid laws of the specific country, which you must strictly follow; prior to exporting any firearm you should seek legal counsel.)

6. SIG SAUER is not responsible for any firearm until it is received, nor for damage incurred during shipment.

7. Ship your firearms insured and prepaid (we do not accept collect shipments) to:

SIG SAUER Inc.

Attention: Service Department

18 Industrial Drive Exeter, NH 03833

This instruction manual should always accompany this rifle and be transferred with it upon change of ownership.

WARNING – SHIPPING

BEFORE SHIPPING ANY FIREARM, BE ABSOLUTELY CERTAIN THAT THE FIREARM AND ITS MAGAZINE ARE UNLOADED. DO NOT SHIP AMMUNITION WITH A FIREARM.

ORDER PARTS

In the event you want to order parts for your SIG MPX rifle, contact Customer Service at (603) 610-3000 ext. 1. Have available the serial number of your rifle and the part diagram number for the part(s) you wish to order. A parts list and diagram of the rifle is provided in sections 15.0 through 16.1.

15.0 Parts Diagram

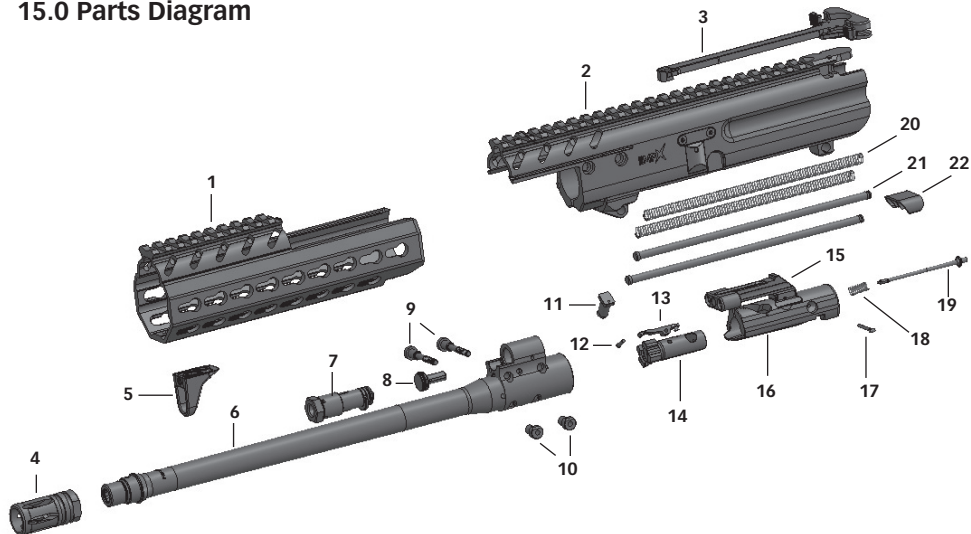

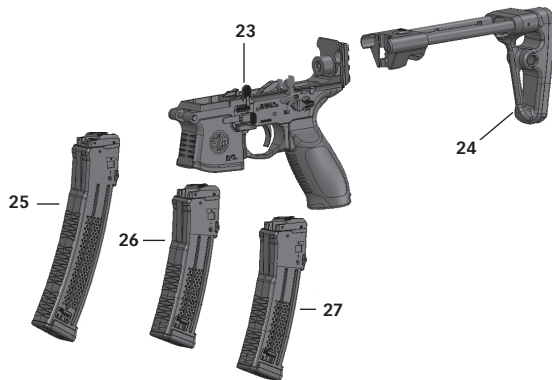

- | | | |
|-----------------------------|-------------------------------------|----------------------------|
| 1 Upper Receiver Assembly | 10 Barrel Clam Screw Nut | 19 Firing Pin |
| 2 Handguard | 11 Cam Pin | 20 Recoil Spring |
| 3 Charging Handle | 12 Firing Pin | 21 Spring Rod |
| 4 Flash Suppressor | 13 Extractor with Spring and O-Ring | 22 Spring Plate |
| 5 Handstop | 14 Bolt Body | 23 Lower Receiver Assembly |
| 6 Barrel/Gas Block Assembly | 15 Op Rod | 24 Collapsible Stock |
| 7 Gas Valve | 16 Bolt Carrier | 25 30 Rd Magazine |
| 8 Piston | 17 Firing Pin Retaining Pin | 26 20 Rd Magazine |
| 9 Screw, Barrel Clamp | 18 Firing Pin Spring | 27 10 Rd Magazine |

SIG SAUER® Limited Lifetime Firearms Warranty

SIG SAUER warrants that the enclosed firearm was originally manufactured free of defects in material, workmanship and mechanical function. For the lifetime of the original purchaser, SIG SAUER agrees to correct any defect in the firearm for the original purchaser by repair, adjustment or replacement, at SIG SAUER's option, with the same or comparable quality components (or by replacing the firearms at SIG SAUER's option); provided, however, that the firearm is returned unloaded and freight prepaid to SIG SAUER at 18 Industrial Drive, Exeter, NH 03833.

This limited warranty is null and void if the firearm has been misused, damaged (by accident or otherwise), fired with handloaded, reloaded or improper ammunition, fired with an obstruction in the barrel, damaged through failure to provide reasonable and necessary maintenance as described in the manual accompanying the firearm, or if unauthorized repair or any alteration, including of a cosmetic nature, has been performed on the firearm. This limited warranty does not apply to normal wear and tear of any parts.

Subject to the foregoing, this limited warranty confers the right to have the covered firearm or its parts repaired, adjusted or replaced exclusively upon the original purchaser, which right is not transferable to any other person. No implied warranties of any kind are made herein and this warranty does not apply to any accessory items attached or appurtenant to the firearm. In no event shall SIG SAUER be liable for any incidental or consequential damages arising from or in connection with this limited warranty.

Notes:

Notes:

SIGSAUER[®]
when it counts[®]

www.sigsauer.com

**FOR PRODUCT SERVICE ON THIS MODEL,
PLEASE CALL (603) 610-3000 EXT. 1**

72 Pease Boulevard, Newington, NH 03801 USA