



SU-16 RIFLE

SU-16A, SU-16B, SU-16C, and SU-16CA

KEL-TEC CNC INDUSTRIES INC.

1505 COX ROAD
COCOA FL 32926
321-631-0068
www.kel-tec.com

"THE USE OF A LOCKING DEVICE OR SAFETY LOCK IS ONLY ONE ASPECT OF RESPONSIBLE FIREARM STORAGE. FIREARMS SHOULD BE STORED UNLOADED AND LOCKED IN A LOCATION THAT IS BOTH SEPARATE FROM THEIR AMMUNITION AND INACCESSIBLE TO CHILDREN AND OTHER UNAUTHORIZED PERSONS."



OWNED

MADE

PARTS ©



SAFETY, INSTRUCTION,

AND PARTS MANUAL

KEL-TEC SU-16 RIFLE

SAFETY, INSTRUCTION & PARTS MANUAL

STATEMENT OF LIABILITY

This rifle may be classified as a dangerous weapon and is surrendered by KEL-TEC CNC INDUSTRIES INC. with the understanding that the purchaser assumes all liability resulting from unsafe handling or any action that constitutes a violation of any applicable laws or regulations. Firearms can cause serious injury and death. Safety must be the prime consideration of anyone who handles firearms. Always treat a firearm as though it were loaded. Always keep the muzzle pointed in a safe direction.

In owning a firearm, you are responsible for the firearm's safety and security. Always secure firearms from children.

READ THESE INSTRUCTIONS AND WARNINGS CAREFULLY, BE SURE YOU UNDERSTAND THESE INSTRUCTIONS AND WARNINGS BEFORE USING THIS FIREARM.

This SAFETY, INSTRUCTION & PARTS MANUAL should always accompany this firearm and be transferred with it upon change of ownership or when the firearm is loaned or presented to another person. A copy of the SAFETY, INSTRUCTION & PARTS MANUAL is available FREE upon request and can also be downloaded from the internet at: <http://www.Kel-Tec.com>.

READ AND CAREFULLY FOLLOW THESE WARNINGS AND INSTRUCTIONS

These warnings and instructions are provided to assure the safe functioning of the rifle. Failure to heed them may result in improper functioning and serious injury.

Kel-Tec firearms are designed to function reliably with proper care and knowledgeable use. Do not use your firearm unless you fully understand these instructions, and the safe operation of your firearm.

Only safe gun-handling habits will ensure the safe use of your firearm. This is your responsibility. Accidents are the result of violating the rules of safe gun handling and common sense.

Before handling a firearm, understand its operation.

Never accept or pick up a firearm without checking the magazine and the chamber to assure the weapon is empty. Do not trust the extractor to clear the chamber, look and feel.

Always make sure the muzzle is pointed in a safe direction at all times.

Never point a firearm at anyone or anything you do not intend to shoot.

Make sure your “audience” is always 5 feet behind you, not next to you when firing.

Keep your firearm unloaded when not in use.

Never keep a loaded firearm in the home or vehicle. Never store a firearm with a cartridge in the chamber.

Never store firearms and ammunition together, keep them locked up and away from children.

Never touch the trigger when working the action. Never alter any components of your firearm.

Never take medications, drugs, or alcohol when handling firearms.

Never load or unload a firearm without assuring the muzzle is pointed in a safe direction.

Never load a firearm except immediately before shooting.

SAFE GUN HANDLING IS YOUR RESPONSIBILITY

The SU-16 rifle is designed and chambered for the 5.56mm NATO (.223 Remington) cartridge. The type of ammunition is also stated on the right side of the receiver. Do not use any other ammunition.

Only use commercially manufactured ammunition, clean, dry, and in good condition. Never use non-standard, reloaded, or damaged cartridges.

Never use ammunition where the pressure levels exceed industry standards. Kel-Tec guns are manufactured from high quality materials. They will provide extended service life. However, all warranties, expressed or implied, are voided and Kel-Tec will not be liable for property damage or personal injury and consequential damages, if faulty ammunition is used in Kel-Tec centerfire firearms.

Discharging firearms in poorly ventilated areas, cleaning firearms, or handling ammunition may result in exposure to lead and other substances known to cause birth defects, reproductive harm, and other serious physical injury. Have adequate ventilation at all times. Wash hands thoroughly after exposure.

Never discharge a firearm without proper shooting glasses and ear protection. Never shoot at any water surface or any surface

where a ricochet can occur.

Never shoot until you are sure of your backstop and what lies beyond it.

If the gun does not discharge after pulling the trigger, do not change its direction for at least 30 seconds, you could be having a “hang fire”.

Do not allow a firearm to be used by individuals who do not understand its safe operation and the rules of safe gun handling.

CAUTION: After firing several rounds the forward, exterior metal parts of the SU-16 rifle get hot and can cause severe burns.

Be sure all accessories are compatible with the firearm and that the accessories do not interfere with safe operation.

When transporting your firearm, be sure your firearm is unloaded.

If you do not understand how to operate any of our products or have any questions about their safe handling, please write, call, or email us.

Always be aware of other people so that they cannot accidentally walk into the line of fire. When firing on a target range, be alert and follow the range officer's commands. Never cross obstacles such as fences or streams with a loaded firearm.

INTRODUCTION

The SU-16 is a semi-automatic rifle chambered for the 5.56mm NATO (.223 Remington) cartridge. The SU-16 rifle will accept most standard M-16 type magazines. The forend can be unfolded to form a bi-pod for more accurate shooting.

The SU-16A model stock has storage space for two 10 round Kel-Tec magazines or one 20 or 30 round magazine. By rotating the stock down and forward, the SU-16A rifle can be reduced to a size of 27x7.5 inches (680x190mm) to facilitate storage.

The SU-16B contains the same features as the SU-16A in addition to a lightweight barrel and aluminum front and rear sights (M-16 style front post).

The SU-16C features a 16 inch heavy barrel with a 1/2-28 inch thread on the front of the muzzle to accept standard attachments such

as a muzzle brake. With the rifle unloaded, chamber clear, and safety on, simply unscrew the knurled thread protector to expose the thread. Apply no more than 20 ft-lbs of torque to these threads. The SU-16C also features a true folding stock that can be fired while the stock is folded. The M-16 style front sight of the SU-16C model is integrated into the gas block. The SU-16C contains a MIL-STD-1913 picatinny rail and features a dustcover as well as a case deflecting operating handle. The SU-16C can not store magazines within the stock and does not contain a rubber butt pad.

The SU-16CA model is a combination of the SU-16C heavy barrel and receiver and the SU-16A stock assembly .

CONSTRUCTION

The receiver, stock, and forend are made of an impact resistant glass reinforced Zytel. The

receiver has an aluminum insert molded into the front to accept the barrel and the serial number.

The stock houses the firing mechanism and has storage for two 10 round magazines (with exception of SU-16C). It is ended with a soft rubber butt plate.

The firing mechanism is of conventional single action type. It has a push bolt safety that blocks the trigger.

Functioning

At the start of this cycle the weapon is assumed already loaded, full magazine inserted, hammer cocked, the safety disengaged and ready to fire.

When The SU-16 rifle's trigger is pulled, the trigger block rotates, lifting up the rear of the sear. This causes the sear to rotate on its axis, disengaging the sear from the hammer. The hammer rotates forward to strike the firing pin, which in turn hits the cartridge primer igniting the powder charge.

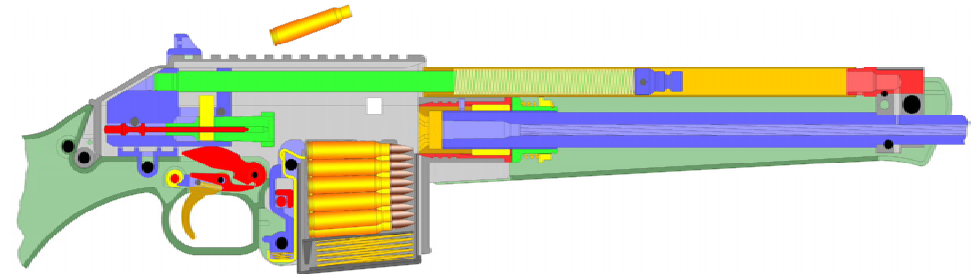
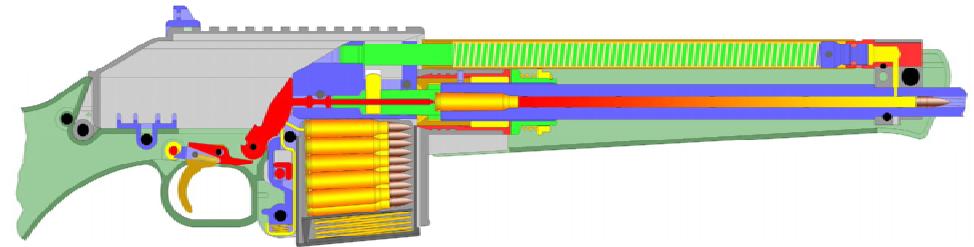
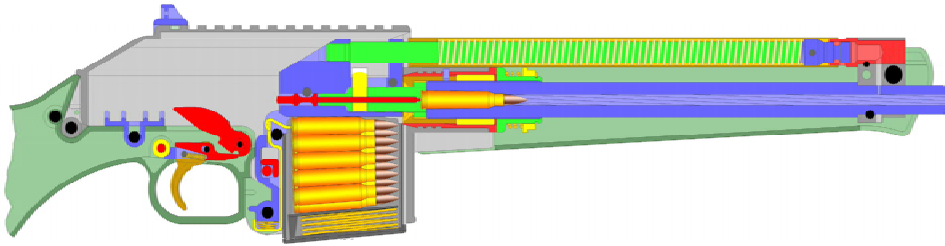

SU-16A/SU-16B

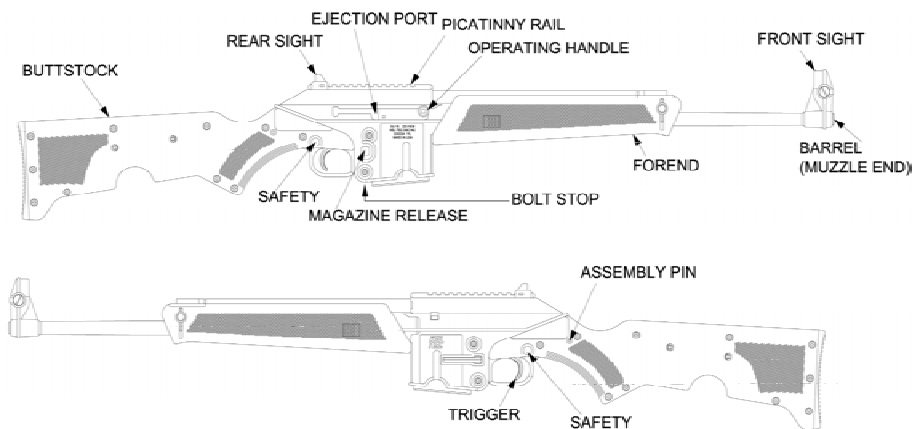

The hot expanding powder gases drive the bullet forward through the barrel. After about .0007 seconds the bullet passes the gas port in the barrel and some of the powder gases enter the gas head and press on the piston. The pressure builds on the piston, which pushes on the piston rod and the bolt carrier causing the bolt carrier to move backwards, unlocking the bolt from the barrel extension. After the bolt carrier moves about 0.41 inches (10.5mm) the bolt is fully unlocked from the

barrel extension and the bolt and empty case continue to move backwards with the bolt carrier.

On it's way backwards, the bolt carrier cocks the hammer and the empty case ejects. The bolt carrier is gradually slowed down and stopped by the recoil spring. The recoil spring then drives the bolt carrier forward. The top cartridge in the magazine is picked up by the bolt and pushed into the barrel. The bolt stops

SU-16C

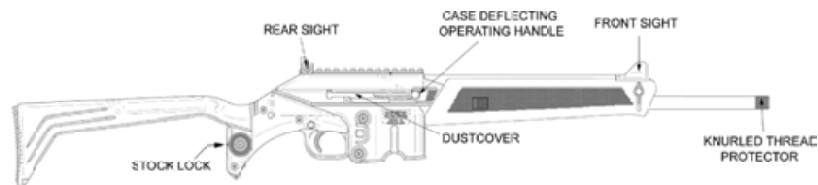

moving once the round is fully inserted into the chamber, but the bolt carrier continues to move forward until it rests on the barrel extension. The cam path and cam pin cause the bolt to twist and lock with the barrel extension.

The hammer is now resting on the sear which is pushing back onto the rear of the trigger block. As the trigger is released the trigger block rotates, lowering the rear of the trigger block which allows the sear to move backwards and rest on the top of the rear of the trigger block. The SU-16 rifle is now ready for the next shot.

INSTRUCTIONS FOR USE

The normal storage condition of the SU-16 rifle is unloaded with the stock folded underneath the barrel.

Folding and unfolding the SU-16A/SU-16B/SU-16C/SU-16CA rifle

To unfold the rifle, remove the assembly pin from its spring locked hole in the receiver. The stock is simply latched onto the barrel with friction and can be unfolded by simply pulling it apart from the barrel. Fully extend the stock and line up the assembly pin holes. Press in the assembly pin until it is flush with the outside of the stock.



To fold the rifle, simply press out the assembly pin with a small tool or the tip of a cartridge, fold the stock under the barrel, and replace the assembly pin into the spring locked hole in the receiver.

Folding and unfolding the SU-16C rifle stock

In order to fold the stock of the SU-16C from the extended position, look behind the grip and you will find the stock lock. Pull down with your thumb and hold to unlock the stock and fold it under the grip. The stock will fold over a 20 or 30 round metal magazine (not included).



It will snap onto the forend with a lot of force. To unfold the stock, simply pull down to unsnap the stock and extend it to lock.

WARNING: Do not get your fingers in the way of the closing or opening stock. Beware of pinch points when opening or closing the stock.

Extending and folding the bipod

To extend the bipod grip the two locking tabs on each side of the forend with your thumb and middle finger. Pull them back until the bi-pod unlatches and then release the bipod. Rotate the bipod forward until it is fully extended. If only one half of the bipod opens, squeeze it closed and try again, being sure to use only two fingers to unlatch the bipod.

To fold up the bipod rotate the bipod back until the locking holes are aligned with the locking tabs. Squeeze the bipod together until both halves snap into place. Be careful not to get any part of your hand in between the two halves when you snap it shut.



Safety

To achieve operator safety, combined with ease of handling, the SU-16 rifle's manual safety, when applied, positively blocks the trigger from rotating the sear. The safety can be applied at any time, whether the hammer is cocked or not. Only when the red ring on the safety is fully obscured is the safety engaged. Obviously the safest condition of the rifle is folded and unloaded. Also considering unauthorized operation, other modes of storing or carrying will gradually improve readiness at the cost of safety.



Malfunctioning

Proper function of your SU-16 rifle is directly related to maintenance and care, and to the ammunition you use. Some of the more common types of malfunctions which may occur are as follows:

Misfire: A failure to fire or an unusual sound upon firing is always a signal to cease firing and immediately examine the bore of the firearm. It is not sufficient to just pull the operating handle back and examine the chamber. You must remove the magazine, clear the chamber, lock the bolt open and inspect the bore visually - and with a rod if necessary - to be certain it is completely clear of any obstruction. Failure to detect and remove a bore obstruction can result in serious injury or death to the shooter and bystanders, as well as damage to the firearm.



WARNING: DO NOT ATTEMPT TO REMOVE A LODGED BULLET OR ANY OTHER OBSTRUCTION BY USING A BLANK CARTRIDGE, OR A CARTRIDGE WITH THE BULLET REMOVED, OR BY ANY MEANS OTHER THAN THE USE OF THE PROPER SIZE CLEANING ROD (WITHOUT A TIP OR BRUSH) AND REASONABLE FORCE APPLIED TO THE ROD. BE CERTAIN ALL LOOSE POWDER HAS BEEN REMOVED FROM THE BORE AND ACTION BEFORE INTRODUCING THE ROD INTO THE BORE.

Failure to Feed: This occurs when a cartridge has been fed from a magazine but not fully chambered. If this occurs, keep the firearm pointed in a safe direction, remove that cartridge, operate the bolt manually and continue shooting. If necessary, change the magazine. The most common causes are dirt or foreign objects impeding the magazine follower. Improperly crimped cartridges are another cause.



Failure to Eject or Extract: A fired case is not fully extracted from the chamber or ejected from the rifle. Again, keep the firearm pointed in a safe direction, clear the gun by operating the bolt, remove the case and continue. If necessary, change the magazine. The most common causes are a damaged extractor, ejector or ammunition. Improperly loaded or sized cartridges can cause this also. If any of the above problems are not solved by cleaning or by use of other brands of ammunition, stop firing, unload and return the SU-16 rifle to our service department.

Firing

With the muzzle pointed in a safe direction and your finger outside the trigger guard, take aim at a safe target, disengage the safety and squeeze the trigger until a round is fired. Release the trigger and you are ready to fire another round. Upon firing, the bolt moves rearward extracting and ejecting the fired round and returns to the forward position feeding another round automatically while doing so. This sequence can be repeated until



the last round has been fired. The SU-16 has an automatic bolt stop so after the last round is fired the bolt will lock open. Remove the empty magazine by pressing the magazine catch located on the right side of the receiver and pull out the empty magazine. To continue shooting, simply insert a full magazine into the magazine well, firmly push it up until it locks, and pull back and release the operating handle to release the bolt stop and feed the next round. The rifle is now ready to fire.

Unloading

To unload the SU-16 rifle, engage the safety, push in the magazine catch, remove the magazine, and pull the operating handle fully back to eject the round in the chamber. Do not obstruct the ejector port and keep fingers away from trigger and muzzle. With the operating handle fully pulled back, push up on the bolt stop and slowly release the operating handle. The bolt should stay open. Visually



inspect the chamber to make sure it is empty. Pull back on the operating handle to release the bolt stop and release the operating handle to close the chamber. Push the remaining cartridges in the magazine forward and out.

Loading

To load, fill the magazine by pressing a cartridge downward on the magazine follower (or downward on the previously loaded cartridge). Continue loading until you have loaded the number of cartridges you wish to load, up to the magazine capacity of 10 rounds. Do not attempt to load your magazine with more than the specified number of rounds. Doing so can damage the magazine and can cause a feeding malfunction. Before inserting a loaded magazine always tap the back of the magazine against a hard surface two or three times in order to properly seat all the cartridges to the rear of the magazine.

With the rifle's safety engaged, hold the rifle in one hand with the muzzle pointing in a safe direction and with your finger off the trigger and outside the trigger guard. Insert the loaded magazine into the grip until it is locked in





SU-16B
Exclusive Parts
Part# 202 Exchange Only

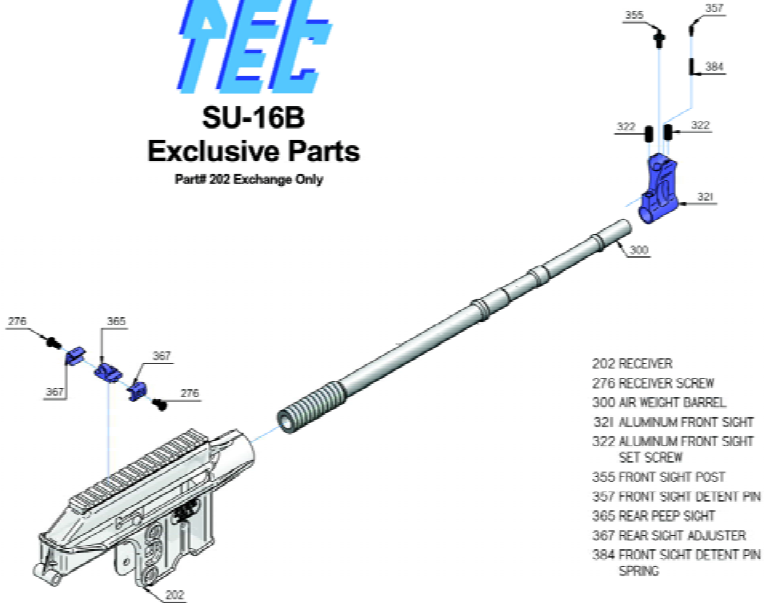

- 202 RECEIVER
- 276 RECEIVER SCREW
- 300 AIR WEIGHT BARREL
- 321 ALUMINUM FRONT SIGHT
- 322 ALUMINUM FRONT SIGHT SET SCREW
- 355 FRONT SIGHT POST
- 357 FRONT SIGHT DETENT PIN
- 365 REAR PEEP SIGHT
- 367 REAR SIGHT ADJUSTER
- 384 FRONT SIGHT DETENT PIN SPRING

For complete listings of SU-16B parts, see the last pages of this manual.



SU-16C
Exclusive Parts

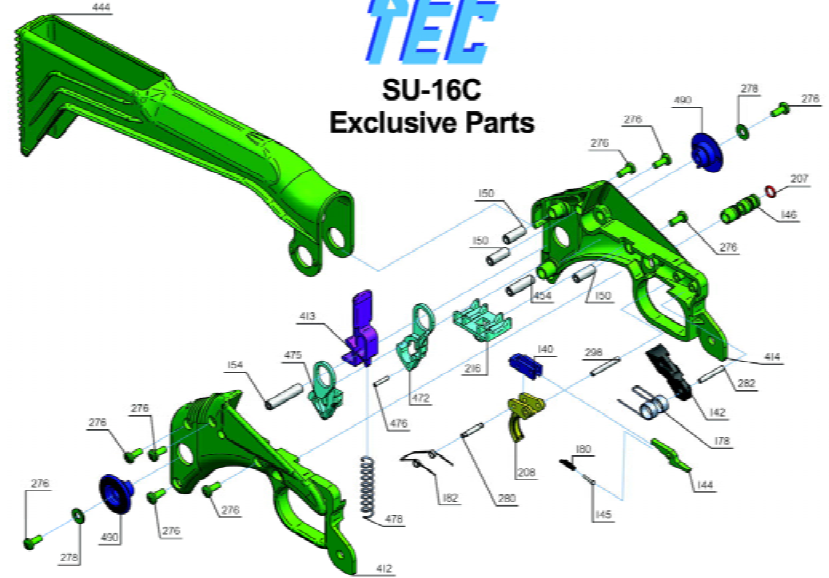

- | | | | | |
|---------------------|--------------------|-----------------------|-----------------------------|-------------------------------|
| 140 TRIGGER BLOCK | 154 SPACER-29 | 216 RECEIVER SPREADER | 412 FOLDING GRIP RIGHT | 475 FOLDING STOCK SNAP RIGHT |
| 142 HAMMER | 178 HAMMER SPRING | 276 RECEIVER SCREW | 413 STOCK LOCK | 476 FOLDING STOCK SNAP PIN |
| 144 SEAR | 180 SEAR SPRING | 278 RECEIVER WASHER | 414 FOLDING GRIP LEFT | 478 FOLDING STOCK SNAP SPRING |
| 145 SEAR SPRING PIN | 182 TRIGGER SPRING | 280 SEAR PIN | 444 FOLDING STOCK | 490 STOCK CAP |
| 146 SAFETY | 207 RED O-RING | 282 HAMMER AXIS | 454 SPACER-21 | |
| 150 STOCK SPACER-16 | 208 TRIGGER | 298 TRIGGER AXIS | 472 FOLDING STOCK SNAP LEFT | |

For complete listings of SU-16C parts, see the last pages of this manual.



SU-16C and SU-16CA Exclusive Parts

Part# 202 Exchange Only

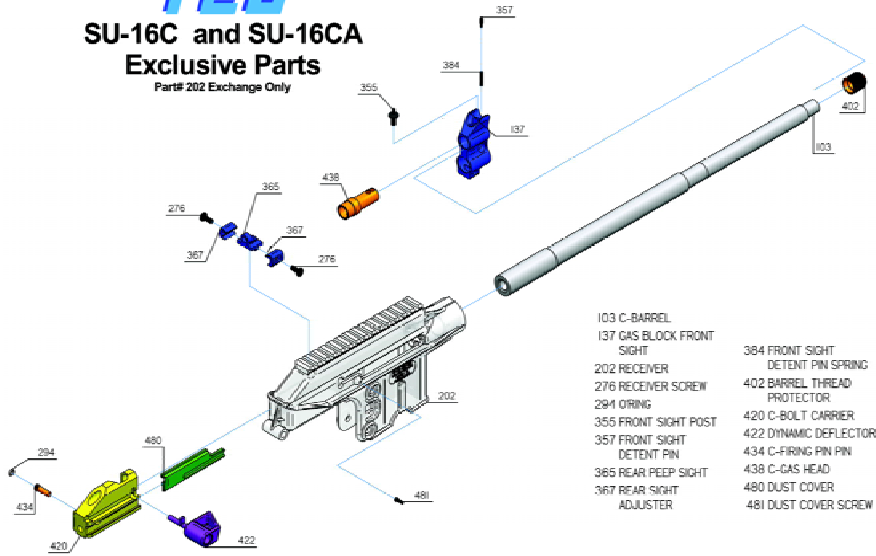

For complete listings of SU-16C/SU-16CA parts, see the last pages of this manual.

place. Check to assure that the magazine is secure. Pull the operating handle back and release. This strips a round from the magazine and seats it in the barrel chamber. If you wish to restore the magazine in your rifle to full capacity, press the magazine catch and remove the magazine to load the missing round. Remember to keep the safety engaged and your rifle pointed in a safe direction under all conditions and always keep your finger off the trigger and outside the trigger guard until ready to fire.

DISASSEMBLY

NOTE: Disassembly can be performed with only a cartridge but a few simple tools such as a small punch and small pliers can make things much easier. A Phillips head screw driver is not necessary for general maintenance and none of the screws on the rifle should ever need to be removed for general maintenance.

Rifle disassembly

Unload your SU-16 rifle and cycle the operating handle to be sure that there is no round in the

chamber. Make sure the bolt is in the forward position and the safety is engaged.

CAUTION: Some accessories that are mounted to the picatinny rail on the top of the receiver may interfere with the disassembly of the SU-16 rifle. It is advisable to remove any scopes or other devices mounted to the rail before proceeding with disassembly.

With a cartridge or other pointed object push out and remove the assembly pin. Fold the stock down and forward and press it onto the barrel. Unlatch the bipod. Grip the recoil spring tube, pull it towards the muzzle and twist it 1/4



turn so that the locking tab points towards the top of the rifle, it should slide into the receiver about 1/4 inch as you release the recoil spring tube. Slowly pull back on the operating handle, the recoil spring tube should also move back and there should not be any spring pressure felt. Pull the handle all the way back and push it down into the operating handle removal cutout in the receiver. The operating handle should now be able to be pulled straight out of the bolt carrier. After the operating handle is removed the bolt carrier assembly can now be guided out of the bottom of the receiver by holding onto the recoil spring tube.

Bolt carrier disassembly

To remove the bolt, cam pin, and firing pin, simply press out the firing pin pin from the right side with a small tool or a cartridge.

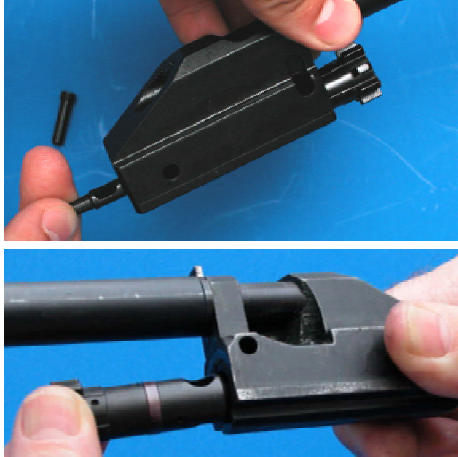

NOTE: For the SU-16C and SU-16CA, in order to remove the firing pin pin, you first must remove the dustcover. Simply pull the bolt out as far as possible, then slide the dustcover forward over the bolt. Some light bending of the dustcover will be required.

Remove the firing pin from the back of the bolt carrier, you may need to tap the bolt carrier or move the bolt in and out to get the firing pin to fall out enough to grip it. With the firing pin removed the cam pin can now be pulled out and with the cam pin out the bolt can be removed from the front of the carrier. To remove the piston head, recoil spring tube, and recoil spring, first align the holes in the recoil spring tube with the pin in the piston head. While holding the piston head with one hand, press out the piston pin with the firing pin or a small tool.

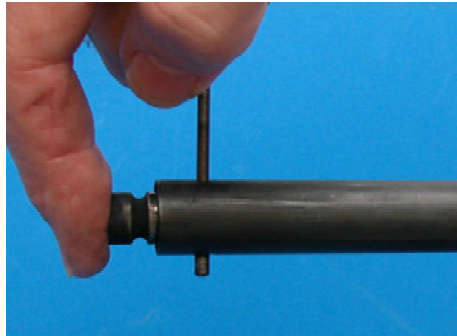

CAUTION: The piston head is under pressure from the compressed recoil spring and the piston head and recoil spring can easily fly out and injure yourself or bystanders, always keep a hand on the piston head and point the piston head in a safe direction when removing it.

With the piston pin removed the piston head is now free to be taken off. Slide the recoil spring tube off the piston rod and remove the recoil spring from the recoil spring tube.

NOTE: It is not recommended that you disassemble the stock of the SU-16 rifle; the hammer spring is constantly under tension and can easily injure you or others.

ASSEMBLY

Bolt carrier assembly

To install the piston head, recoil spring tube,



and recoil spring, insert the recoil spring into the recoil spring tube. Slide the recoil spring tube with recoil spring onto the piston rod. Align the holes in the recoil spring tube with the hole in the piston rod. Push the piston head onto the recoil spring and onto the piston rod. Insert the firing pin or similar tool into the piston head hole to temporarily hold the piston head in place. While slowly pulling out the firing pin, push in the piston pin from the other side until it is flush with the piston head. Twist the recoil spring tube so that the locking tab points

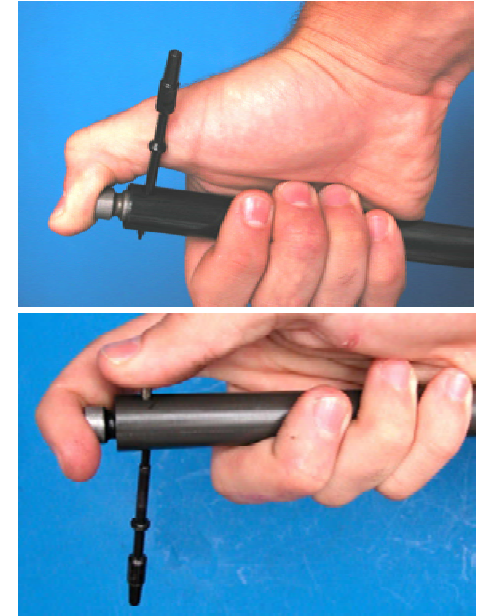

towards the top of the bolt carrier. Check the operation of the recoil spring by lightly pulling on the recoil spring tube to compress the spring.

To install the bolt, cam pin, firing pin, and firing pin pin, insert the bolt into the front of the bolt carrier.

NOTE: For the SU-16C and the SU-16CA, the dustcover should be slid on from the front of the carrier before the bolt is inserted.

Twist the bolt so that the extractor is on the right side of the carrier and the cam pin hole in the bolt lines up with the cam pin slot in the bolt carrier. Insert the cam pin into the hole in the bolt, be sure that the tab on the cam pin is pointing straight out the left side of the bolt carrier. Push the bolt assembly into the carrier as far as it will go and then insert the firing pin into the back of the bolt carrier, being sure the half moon shaped cut is facing up. If it does not go in all the way, the cam pin or the bolt may



not be inserted correctly. Insert the firing pin into the bolt carrier from the left side. DO NOT FORCE THE FIRING PIN. If it does not go in easily, check that the firing pin is installed correctly. Check the operation of the bolt and firing pin to be sure that they move freely.

Rifle assembly

With the rifle stock folded and the bipod unlatched, rest the rifle on its left side. Take the bolt carrier assembly, pull the bolt out as far as it will go, and twist the recoil spring tube so that the lock tab is at the top of the bolt carrier. Insert the carrier from the rear of the receiver, be sure not to twist the bolt tube or push in the bolt as you insert it. **For the SU-16C, make sure the slot in the dustcover aligns**



correctly with the screw head on the inside of the receiver. The rear of the dustcover should be flush with the back of the bolt carrier. Align the operating handle hole in the carrier with the cut-out in the receiver and insert the operating handle. Push the carrier up slightly so that the operating handle aligns with the slot for it and the recoil spring tube is parallel with the barrel of the rifle.

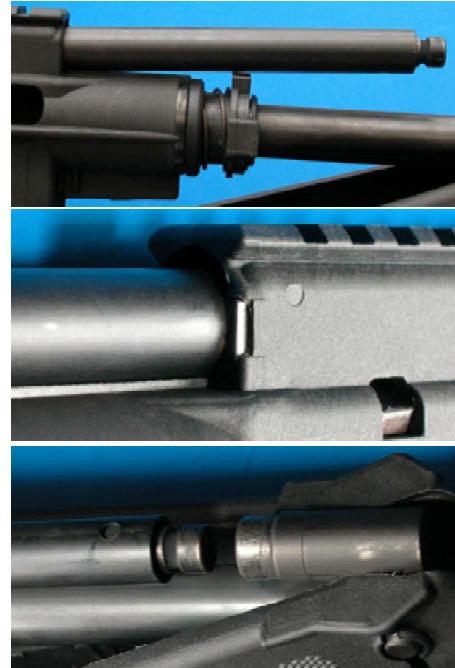

WARNING: If the recoil spring tube is not parallel with the barrel of the rifle the bolt carrier assembly is not installed correctly. Remove the carrier assembly and install it again paying close attention to the alignment of the lock tab on the recoil spring tube as you insert the carrier and also be sure that the bolt itself is always in the forward most position as you insert the carrier assembly into the receiver.

Check that the forend lock ring is aligned correctly and push the operating handle all the way forward, be sure that the piston head lines up and goes into the gas head. Grip the recoil spring tube, pull it forward, and twist 1/4 turn so that the locking tab on the recoil spring tube goes into the receptacle on the left side of the receiver. Pull the operating handle back and forth to check that it moves freely. If it does not take out the bolt carrier and check to make sure everything is installed correctly and nothing is damaged. Close the bipod and unfold the stock. Insert the assembly pin into the hole and press it in until it is flush with the outside of the stock.

Changing the safety operation direction:

The safety button on the SU-16 rifle can be reversed so that the safety can be engaged by either pressing on the right side, or the left side of the safety button, depending on your preferences. You will need a few tools to flip

the safety button, including a Philips head screw driver, a small flat head screw driver, or other thin tool for prying, and a small paper clip. Bend the paper clip out so that it has a small hook on one end and a handle shape on the other as shown in the figure.



Unload your SU-16 rifle and cycle the operating handle to be sure that there is no round in the chamber. Make sure the bolt is in the forward position and the safety is engaged. Put the rifle on one of its sides and loosen the four screws on the stock that are closest to the muzzle end of the rifle as shown in the figure. Do not loosen screws that are screwed into the receiver. Flip the rifle over and loosen the four screws that were in the same position as the previous four you just loosened. Hold the rifle so that it is upside down and resting on its top. You may need to remove the sight and any other accessories that are mounted to the picatinny rail. Push your small screwdriver or prying tool into the gap in the bottom rear of the trigger guard so that there is enough of a gap to get your paper clip tool in between the two



stock halves at the back of the base of the trigger guard. You may need another prying tool to help enlarge the gap. Put your paper clip hook into the gap you just pried open. Start from the butt end and move the hook towards the trigger, you should be able to hook onto the back of the trigger spring. Lift up on your tool to raise the trigger spring. While holding the spring up, push out the safety, flip it around, and put it back. Release the pressure on the trigger spring and remove the paper clip hook. Check to be sure that the safety moves back and forth correctly. Remove the pry tool from the trigger guard. Tighten all the screws that you loosened on both sides of the stock. Check the operation of the safety before loading the rifle.

SIGHT ADJUSTMENT SU-16A

Sight adjustment on the SU-16A rifle depends on the placement of the rear sight. If the sight is placed farthest forward on the picatinny rail,



the rifle will have a different sight radius than if the sight is placed farthest rearward on the picatinny rail. The data below is given for when the rear sight is placed on the farthest rearward slot on the picatinny rail. The rear sight of the SU-16A can be removed by pushing out the cross bar in the sight with a small punch or similar tool. With the cross bar out, the sight can be slid forward or off of the rail. Reinstall the cross bar to lock the sight in position. The rear sight of the SU-16B/SU-16C/SU-16CA can be removed by fully unscrewing one of the screws on the side of the sight.

Before making any adjustment, always loosen the metal screw first. Reverse the Phillips head bit in the included tool and use the hex end to loosen one plastic screw and then tighten the other in 1/8 to 1/4 turn increments. Always end by tightening the right side screw in order to avoid sight blade rotation. **DO NOT OVERTIGHTEN THE CLEAR PLASTIC SCREWS**, the hex strips easily. 1/4 of a turn changes the point of impact 1.3" at 100 yards or 1.3 m.o.a. . One full turn is 5.2 m.o.a. By turning the left screw clockwise (in) the sight moves to the right and the point of impact to the left.

Before tightening the screws, the post may be pushed up or down to adjust elevation. .007" will change the impact 1 m.o.a. When you are finished adjusting the sight, lock the blade by tightening the metal screw.

SIGHT ADJUSTMENT SU-16B/SU-16C/SU-16CA

Sight adjustment on the SU-16B/SU-16C/SU-16CA rifle depends on the placement of the rear sight. If the sight is in the farthest forward slot on the picatinny rail the rifle will have a different sight radius than if the sight is placed farthest rearward on the picatinny rail. The data given is for the sight in the rearmost position.

Use the included Phillips driver to adjust the windage with the two screws on the sides of the rear sight. Tighten the screw on the same side of the rear sight that you want to move the point of impact to. You may have to loosen the opposite side screw a little.

For example: to move the point of impact left 1 inch at 100 yards you would loosen (counter-clockwise) the right screw 1/8 turn and tighten (clockwise) the left screw 1/8 turn.

For the front sight, use a small tipped tool, like a paper clip or an M-16 A2 style front sight tool (not included) to depress the detent pin and turn the sight post by hand. One click (1/4 turn) will change the point of impact 1.2inches at 100 yards on the SU-16B; and 1.6inches at

100 yards on the SU-16C and SU-16CA. Clockwise (in) moves the point of impact up and counter-clockwise (out) moves it down.

MAINTENANCE

Your rifle is a precision instrument and to insure reliable function, it is necessary to follow a routine maintenance procedure. After firing your rifle, be sure to unload it following the procedure outlined in the section entitled "Unloading" before any cleaning or maintenance procedure.

Routine cleaning, after every shooting session:

Your rifle should be cleaned by brushing the barrel bore and chamber with a good powder-removing solvent and bore brush. Wipe the areas clean with patches or a swab. Using a small brush dipped in solvent, remove all deposits from around the breech of the barrel,

chamber, extractor, and adjacent areas which have been subjected to the action of powder or primer residue. Remove any residue on the frame with light brushing and a solvent. After cleaning the entire gun, use a cloth to apply a light coating of high quality gun oil to all external surfaces and wipe clean.

Additional cleaning, after firing 500 rounds:

Remove the bolt carrier assembly and fully disassemble it as stated in the disassembly section of this manual. Thoroughly clean, with solvent and a brush, the piston head, piston pin, piston rod, recoil spring, recoil spring tube, bolt, cam pin, firing pin, and bolt carrier. Do not clean the firing pin pin, solvents can damage the O-ring used to hold it in place. Thoroughly dry all parts. Apply a light coat of oil to the firing pin, bolt, cam pin, and the surfaces in the bolt carrier where the bolt, cam pin, and firing pin slide. Apply a light coat of oil on the piston rod and assemble the bolt carrier assembly and rifle as stated in the assembly part of this manual. Manually cycle the bolt back and forth to check the function of the rifle. If any parts are damaged or badly worn or the rifle does not work correctly, the rifle should not be fired and should be returned to Kel-Tec for servicing immediately.

LUBRICATION WARNING:
Firing a rifle with oil, grease, or any other material even partially obstructing the bore may damage the rifle and injure the shooter and those nearby.

Do not spray or apply lubricants directly on ammunition. If the powder charge of a cartridge is affected by the lubricant, it may not be ignited, but the energy from the primer may be sufficient to push the bullet into the bore where it may become lodged. Firing a subsequent bullet into the obstructed bore will damage the rifle and may injure the shooter and bystanders. Use lubricants properly. You are responsible for the proper care and maintenance of your firearm.

WARNING: It is not recommended that you disassemble the stock of the SU-16 rifle; the hammer spring is constantly under tension and can easily injure you or others. If the need arises to lubricate the trigger assembly do so through the access slot behind and in front of the hammer.



Service

Should your SU-16 rifle require adjustment, refinishing, or repair, it should be returned unloaded to the factory. In shipping the SU-16 rifle, be sure to adhere to the following rules:

Individuals who wish to return the firearm for service can do so by shipping via UPS prepaid. No return authorization number is required.

Include a letter of instruction, full name, address, phone number and the gun's serial number. This will insure prompt service and handling. Once your rifle has been received, anything other than warranty work, will receive a quotation. You will be notified of full charges and no work will commence before receiving your approval of our quotation. Also see Warranty Page for further instructions. All quotations are payable by C.O.D., VISA, M.C. or money orders only. No personal checks accepted. Please return your SU-16 rifle to:

Kel-Tec CNC, Inc
Service Department
1475 Cox Road
Cocoa, FL 32926.

WARRANTY

This warranty is granted by Kel-Tec CNC Industries, Inc. P.O. Box 236009, Cocoa, FL 32923. This lifetime warranty is effective from the date of purchase and applies to the original owner of a Kel-Tec SU-16 rifle.

Kel-Tec firearms are warranted to be free from defects in material and workmanship. Any such defects of which Kel-Tec receives written notice by the original owner, will be remedied by Kel-Tec without charge within a reasonable time after such notification and delivery of the product as provided below.

Warranty claims (in writing) and the gun concerned should be delivered (transportation charges pre-paid) to:

Kel-Tec CNC, Inc
Service Department
1475 Cox Road
Cocoa, FL 32926.

No return authorization number is required. In addition, a copy of a bill of sale in the owner's name, or a copy of ATF Form 4473, indicating date of purchase must be included.

In order to expedite service, warranty claims should state the model and serial number of the gun concerned and a description of the difficulty experienced. It is recommended that shipments be insured by the owner, since Kel-Tec will accept no responsibility for loss or damage in transit.

Transportation and insurance charges for return to owner will be paid by Kel-Tec if the claim is covered by the warranty.

Under no circumstances shall Kel-Tec be responsible for incidental or consequential damages with respect to economic loss or injury or property damage, whether as a result of breach of express or implied warranty, negligence or otherwise. Some states do not allow the exclusion or limitation or incidental or consequential damages, so the above limitation or exclusion may not apply to you.

Kel-Tec will not be responsible for defects resulting from careless handling, unauthorized adjustments or modifications, defective or improper ammunition, corrosion, neglect, abuse, ordinary wear and tear, or unreasonable use.

KEL-TEC CNC INDUSTRIES INC.



SU-16A RIFLE PARTS LIST

Part # 202 Exchange Only

100-BARREL
102-BARREL NUT
104-BARREL EXTENSION
108-BARREL RETAINER
110-BOLT
112-EXTRACTOR
114-EXTRACTOR AXIS
116-EJECTOR
118-FIRING PIN
120-BOLT CARRIER
122-OPERATING HANDLE
124-PISTON ROD
126-CAM PIN
128-RECOIL SPRING CATCH
130-PISTON HEAD
132-RECOIL SPRING TUBE
134-FIRING PIN PIN
136-GAS BLOCK
138-GAS HEAD
140-TRIGGER BLOCK
142-HAMMER
144-SEAR
145-SEAR SPRING PIN
146-SAFETY
148-FOREND AXIS
150-STOCK SPACER-16
152-MAG SNAP PIN-SHORT
154-SPACER-29
158-ASSEMBLY PIN
159-MAG SNAP PIN-LONG
172-FOREND LOCK SPRING
174-RECOIL SPRING
176-MAGAZINE CATCH SPRING
178-HAMMER SPRING
180-SEAR SPRING
182-TRIGGER SPRING
186-STOCK PIN SPRING
188-MAGAZINE SNAP SPRING
190-BOLT STOP SPRING
192-FOREND SPREADER SPRING
194-EXTRACTOR SPRING
196-EJECTOR SPRING
198-MAGAZINE SPRING
202-RECEIVER
203-DRIVER HOUSING
204-MAG WELL
205-PHILLIPS DRIVER
206-FRONT SIGHT
207-RED O'RING
208-TRIGGER
210-EXTRACTOR SPRING BUFFER
212-STOCK-RIGHT
214-STOCK-LEFT
216-RECEIVER SPREADER
218-FOREND-RIGHT
220-FOREND-LEFT
226-FOREND LOCK
228-BOLT STOP
230-REAR SIGHT-PEEP
232-REAR SIGHT LOCK
234-MAG CATCH
236-FRONT SIGHT SCREW
240-FRONT SIGHT POST
244-RECOIL PAD
252-MAGAZINE HOUSING
254-MAGAZINE FOLLOWER
256-MAGAZINE PLATE
258-MAGAZINE BOTTOM
268-SAFETY/OPERATION MANUAL
274-EJECTOR PIN
276-RECEIVER SCREW
278-RECEIVER WASHER
280-SEAR PIN
282-HAMMER AXIS
283-FRONT SIGHT LOCK SCREW
284-BARREL EXTENSION PIN
285-FRONT SIGHT LOCK NUT
286-FOREND PIN
288-F.E. LOCK RETAINING RING
290-MAG SNAP E-RING
294-O'RING
296-PISTON PIN
298-TRIGGER AXIS
299-GAS BLOCK PIN
310-MAGAZINE ASSEMBLY

SU-16B RIFLE PARTS LIST

Part # 202 Exchange Only

102-BARREL NUT
104-BARREL EXTENSION
106-FRAME BUSHING
108-BARREL RETAINER
110-BOLT
112-EXTRACTOR
114-EXTRACTOR AXIS
116-EJECTOR
118-FIRING PIN
120-BOLT CARRIER
122-OPERATING HANDLE
124-PISTON ROD
126-CAM PIN
128-RECOIL SPRING CATCH
130-PISTON HEAD
132-RECOIL SPRING TUBE
134-FIRING PIN PIN
136-GAS BLOCK
138-GAS HEAD
140-TRIGGER BLOCK
142-HAMMER
144-SEAR
145-SEAR SPRING PIN
146-SAFETY
148-FOREND AXIS
150-STOCK SPACER-16
152-MAG SNAP PIN-SHORT
154-SPACER-29
158-ASSEMBLY PIN
159-MAG SNAP PIN-LONG
172-FOREND LOCK SPRING
174-RECOIL SPRING
176-MAGAZINE CATCH SPRING
178-HAMMER SPRING
180-SEAR SPRING
182-TRIGGER SPRING
186-STOCK PIN SPRING
188-MAGAZINE SNAP SPRING
190-BOLT STOP SPRING
192-FOREND SPREADER SPRING
194-EXTRACTOR SPRING
196-EJECTOR SPRING
198-MAGAZINE SPRING
202-RECEIVER
203-DRIVER HOUSING
204-MAG WELL
205-PHILLIPS DRIVER
207-RED O'RING
208-TRIGGER
210-EXTRACTOR SPRING BUFFER
212-STOCK-RIGHT
214-STOCK-LEFT
216-RECEIVER SPREADER
218-FOREND-RIGHT
220-FOREND-LEFT
226-FOREND LOCK
228-BOLT STOP
234-MAG CATCH
244-RECOIL PAD
252-MAGAZINE HOUSING
254-MAGAZINE FOLLOWER
256-MAGAZINE PLATE
258-MAGAZINE BOTTOM
268-SAFETY/OPERATION MANUAL
274-EJECTOR PIN
276-RECEIVER SCREW
278-RECEIVER WASHER
280-SEAR PIN
282-HAMMER AXIS
284-BARREL EXTENSION PIN
286-FOREND PIN
288-F.E. LOCK RETAINING RING
290-MAG SNAP E-RING
294-O'RING
296-PISTON PIN
298-TRIGGER AXIS
299-GAS BLOCK PIN
300-AIR WEIGHT BARREL
310-MAGAZINE ASSEMBLY
321-ALUMINUM FRONT SIGHT
322-ALUMINUM FRONT SIGHT SET SCREW
355-FRONT SIGHT POST
357-FRONT SIGHT DETENT PIN

SU-16C RIFLE PARTS LIST

Part # 202 Exchange Only

102-BARREL NUT
103-BARREL CARBINE
104-BARREL EXTENSION
108-BARREL RETAINER
110-BOLT
112-EXTRACTOR
114-EXTRACTOR AXIS
116-EJECTOR
118-FIRING PIN
124-PISTON ROD
126-CAM PIN
128-RECOIL SPRING CATCH
130-PISTON HEAD
132-RECOIL SPRING TUBE
137-GAS BLOCK FRONT SIGHT
140-TRIGGER BLOCK
142-HAMMER
144-SEAR
145-SEAR SPRING PIN
146-SAFETY
148-FOREND AXIS
150-STOCK SPACER-16
154-SPACER-29
158-ASSEMBLY PIN
172-FOREND LOCK SPRING
174-RECOIL SPRING
176-MAGAZINE CATCH SPRING
178-HAMMER SPRING
180-SEAR SPRING
182-TRIGGER SPRING
186-STOCK PIN SPRING
190-BOLT STOP SPRING
192-FOREND SPREADER SPRING
194-EXTRACTOR SPRING
196-EJECTOR SPRING
198-MAGAZINE SPRING
202-RECEIVER
203-DRIVER HOUSING
204-MAG WELL
205-PHILLIPS DRIVER
207-RED O'RING
208-TRIGGER
210-EXTRACTOR SPRING BUFFER
216-RECEIVER SPREADER
218-FOREND-RIGHT
220-FOREND-LEFT
226-FOREND LOCK
228-BOLT STOP
234-MAG CATCH
252-MAGAZINE HOUSING
254-MAGAZINE FOLLOWER
256-MAGAZINE PLATE
258-MAGAZINE BOTTOM
268-SAFETY/OPERATION MANUAL
274-EJECTOR PIN
276-RECEIVER SCREW
278-RECEIVER WASHER
280-SEAR PIN
282-HAMMER AXIS
284-BARREL EXTENSION PIN
286-FOREND PIN
288-F.E. LOCK RETAINING RING
294-O'RING
296-PISTON PIN
298-TRIGGER AXIS
299-GAS BLOCK PIN
310-MAGAZINE ASSEMBLY
355-FRONT SIGHT POST
357-FRONT SIGHT DETENT PIN
365-REAR PEEP SIGHT
367-REAR SIGHT ADJUSTER
384-FRONT SIGHT DETENT PIN SPRING
402-BARREL THREAD PROTECTOR
412-FOLDING GRIP RIGHT
413-STOCK LOCK
414-FOLDING GRIP LEFT
420-C-BOLT CARRIER
422-DYNAMIC DEFLECTOR
434-C-FIRING PIN PIN
438-C-GAS HEAD
444-FOLDING STOCK
454-SPACER-21
472-FOLDING STOCK SNAP LEFT
475-FOLDING STOCK SNAP RIGHT
476-FOLDING STOCK SNAP PIN
478-FOLDING STOCK SNAP SPRING
480-DUST COVER
481-DUST COVER SCREW
490-STOCK CAP

SU-16CA RIFLE PARTS LIST

Part # 202 Exchange Only

102-BARREL NUT
103-BARREL CARBINE
104-BARREL EXTENSION
108-BARREL RETAINER
110-BOLT
112-EXTRACTOR
114-EXTRACTOR AXIS
116-EJECTOR
118-FIRING PIN
124-PISTON ROD
126-CAM PIN
128-RECOIL SPRING CATCH
130-PISTON HEAD
132-RECOIL SPRING TUBE
137-GAS BLOCK FRONT SIGHT
140-TRIGGER BLOCK
142-HAMMER
144-SEAR
145-SEAR SPRING PIN
146-SAFETY
148-FOREND AXIS
150-STOCK SPACER-16
152-MAG SNAP PIN-SHORT
154-SPACER-29
158-ASSEMBLY PIN
159-MAG SNAP PIN-LONG
172-FOREND LOCK SPRING
174-RECOIL SPRING
176-MAGAZINE CATCH SPRING
178-HAMMER SPRING
180-SEAR SPRING
182-TRIGGER SPRING
186-STOCK PIN SPRING
188-MAGAZINE SNAP SPRING
190-BOLT STOP SPRING
192-FOREND SPREADER SPRING
194-EXTRACTOR SPRING
196-EJECTOR SPRING
198-MAGAZINE SPRING
202-RECEIVER
203-DRIVER HOUSING
204-MAG WELL
205-PHILLIPS DRIVER
207-RED O'RING
208-TRIGGER
210-EXTRACTOR SPRING BUFFER
212-STOCK-RIGHT
214-STOCK-LEFT
216-RECEIVER SPREADER
218-FOREND-RIGHT
220-FOREND-LEFT
226-FOREND LOCK
228-BOLT STOP
234-MAG CATCH
244-RECOIL PAD
252-MAGAZINE HOUSING
254-MAGAZINE FOLLOWER
256-MAGAZINE PLATE
258-MAGAZINE BOTTOM
268-SAFETY/OPERATION MANUAL
274-EJECTOR PIN
276-RECEIVER SCREW
278-RECEIVER WASHER
280-SEAR PIN
282-HAMMER AXIS
284-BARREL EXTENSION PIN
286-FOREND PIN
288-F.E. LOCK RETAINING RING
290-MAG SNAP E-RING
294-O'RING
296-PISTON PIN
298-TRIGGER AXIS
299-GAS BLOCK PIN
310-MAGAZINE ASSEMBLY
355-FRONT SIGHT POST
357-FRONT SIGHT DETENT PIN
365-REAR PEEP SIGHT
367-REAR SIGHT ADJUSTER
384-FRONT SIGHT DETENT PIN SPRING
402-BARREL THREAD PROTECTOR
420-C-BOLT CARRIER
422-DYNAMIC DEFLECTOR
434-C-FIRING PIN PIN
438-C-GAS HEAD
480-DUST COVER
481-DUST COVER SCREW