



TM

REPR

RAPID ENGAGEMENT PRECISION RIFLE

USER MANUAL



**DO NOT OPERATE YOUR RIFLE UNTIL YOU
HAVE READ AND UNDERSTAND THIS MANUAL**





INTRODUCTION

Thank you for purchasing the LWRCI Rapid Engagement Precision Rifle (R.E.P.R.). LWRCI's goal with the R.E.P.R. was to design and deliver a self-loading rifle that is more reliable, user friendly, and has accuracy comparable to a bolt-action sniper rifle.

R.E.P.R. is loosely based on the proven Stoner AR architecture of modular upper and lower receiver groups. Rapidly interchangeable Upper Receiver Groups from the short R.E.P.R. 12 (12.7" barrel) to the R.E.P.R. 20 (20" barrel) allow operators to reconfigure their R.E.P.R.s to meet and dominate evolving tactical situations.

Many of the excellent ergonomics associated with the AR platform are retained. One exception is the side charging handle. The R.E.P.R. employs a left-side non-reciprocating charging handle with an integrated forward assist. This has the advantage of enabling the user to operate the action while maintaining cheek weld and keeping eyes on target. The location also allows for greater mechanical leverage during manipulation. Another benefit of eliminating the dorsal charging handle is a tighter fit between the stern of the upper and lower receivers that alleviates gas blowback into the user's eyes when employing the weapon with a suppressor.

Our R.E.P.R. rifles feature an adjustable gas system. Four positions (O-Off, S-Suppressed, N-Normal, and A-Adverse) allow for optimum performance in any situation.

Barrel blanks for the R.E.P.R. rifles are cold-rotary hammer forged on a high-precision mandrel to produce match-grade polygonal rifled blanks which are extremely consistent with outstanding bore surfaces. The blanks are then machined with profiles that maximize accuracy and minimize the effects of barrel whip and harmonics. The muzzle has a target crown concentric to the bore to further

enhance accuracy. Finally the barrel is finished with the NiCorr™ surface conversion process both internally and externally. As a surface conversion, NiCorr™ does not require micro-relief of the bore with hard chrome nor does it suffer galling and flaking at high temperature. It is also harder/more wear resistant, has a lower coefficient of friction, holds structural integrity at higher temperatures, and is more resistant to corrosion. The net result is an extremely accurate barrel with extended barrel life and tolerance for aggressive use.

The moving parts of the action are all coated in NiBor™, a very hard plating process that includes a Nickel composite which serves as a permanent lubricant. It minimizes the need for break-in and liquid lubrication and contributes to an extremely smooth yet positive reciprocating action.

R.E.P.R. brings together technology and innovation with superior ergonomics and functionality to better serve the operator.

LWRC INTERNATIONAL, LLC
815 Chesapeake Drive
Cambridge, MD 21613

410.901.1348

410.901.1775 Fax

TABLE OF CONTENTS

1.1 About this Manual.....	6
1.2 Warnings and Safety Data.....	6-7
2.0 General Description of the R.E.P.R. Series	9-10
2.0.1 Technical Data	11
2.1 Weapon Nomenclature.....	12
2.1.1 R.E.P.R. 16	12
2.1.2 R.E.P.R. 20	13
2.1.3 R.E.P.R. 18	14
2.1.4 R.E.P.R. 12	14
2.1.6 Operating Controls	17-24
3.0 Safety Information and Procedures	26
3.1 General Safety Procedures	26-27
3.2 Weapon Conditions	28
3.3 Clearing Your Weapon – Unloading	28-29
3.4 Pre-Fire Function Test.....	29-31
3.5 Pre-Fire Inspection (PFI)	31-32
4.0 Operation.....	34
4.1 Loading a Magazine.....	34
4.2 Loading a Weapon in Condition 4	35
4.3 Firing in Semi-Automatic Mode	35
4.4 Firing in Automatic Mode	36
4.5 Reloading from Bolt Lock	36-37

4.6 Tactical Reload37

4.7 Operating Cycle..... 38-39

5.0 Immediate and Remedial Actions 41

5.1 Immediate Action..... 41

5.2 Remedial Action..... 41-42

6.0 Maintenance 44

6.1 Disassembly (Field Strip) 44-47

6.2 Detailed Disassembly..... 48-55

6.3 Assembly..... 55-56

6.4 Routine Operator’s Maintenance 57-58

6.5 Detailed Operator’s Maintenance..... 58-59

6.6 Maintenance Procedures - Adverse Climate Conditions. 59-60

6.7 Special Arctic Environment Considerations.....60-61

6.8 Lubricants and Cleaners.....61-62

6.9 Rail Maintenance and Notes.....62-63

7.0 Trouble Shooting.....64-66

Warranty67.

1.1 ABOUT THIS MANUAL:

The purpose of this manual is to provide instruction on the safe operation, detail maintenance procedures and provide general information for the R.E.P.R. series of Carbines and Rifles. Thoroughly read this manual prior to operating your weapon and follow all safety rules and procedures outlined within. Ensure that you also observe all Local, State, and Federal Laws when possessing, transporting, or operating your LWRCI firearm.

By following the operating and maintenance procedures outlined in this manual you will ensure proper and safe function of the firearm.

1.2 WARNINGS AND SAFETY DATA:



WARNING! ALWAYS KEEP THE MUZZLE POINTED IN A SAFE DIRECTION WHEN LOADING, UNLOADING, CLEARING OR CHARGING THE WEAPON.



WARNING! WHENEVER THE WEAPON IS SUBMERSED IN WATER IMMEDIATELY SHAKE THE WEAPON, SWINGING THE MUZZLE DOWNWARD VIGOROUSLY, PRIOR TO FIRING TO ENSURE ALL WATER HAS DRAINED FROM THE BARREL



WARNING! NEVER FIRE THE WEAPON WHILE SUBMERSED IN WATER.



WARNING! THE GAS REGULATOR KNOB AND BARREL MAY BECOME HOT ENOUGH TO CAUSE INJURY DURING FIRING. TAKE CARE WHEN CHANGING GAS REGULATOR SETTINGS.

 **WARNING!** ONLY USE AUTHORIZED AMMUNITION THAT IS OF THE CORRECT CALIBER AND IN SERVICEABLE CONDITION. DO NOT LUBRICATE AMMUNITION.

 **WARNING!** WHEN USING A BLANK FIRING ADAPTER (BFA), ENSURE ALL MAGAZINES TO BE FIRED AND EVERY ROUND IN THEM ARE INDEED BLANK AMMUNITION PRIOR TO USING A BFA. FIRING A LIVE ROUND WITH THE BFA IN PLACE COULD CAUSE INJURY OR DEATH!

 **WARNING!** WHEN FIRING, IF YOU HAVE A DRASTIC REDUCTION IN RECOIL AND THE WEAPON DID NOT SOUND RIGHT, UNLOAD TO RANGE SAFE, FIELD DISASSEMBLE AND INSPECT THE BORE TO ENSURE THERE IS NO OBSTRUCTION.

 **WARNING!** NEVER FIRE THE WEAPON WITHOUT THE CAM PIN INSTALLED. THIS COULD RESULT IN INJURY OR DEATH.

 **WARNING!** NEVER KEEP LIVE AMMUNITION NEAR FIREARM OR WORK AREA WHILE DISASSEMBLING OR CLEANING FIREARM.



GENERAL DESCRIPTION OF THE R.E.P.R. SERIES OF RIFLES

The Rapid Engagement Precision Rifle (R.E.P.R.) series are gas piston operated, rotary bolt, magazine-fed, air-cooled, self-loading rifles chambered in **7.62x51mm NATO/.308 Winchester** from LWRC International, LLC.

R.E.P.R.s are available in a number of configurations to fill a variety of mission profiles:



R.E.P.R. 20 – Fitted with a heavy profile 20”(508mm) barrel, 2-stage adjustable match grade trigger and PRS butt stock with adjustable cheek piece and length of pull. It is intended as a precision rifle suitable for engaging point targets out to 800m.



R.E.P.R. 18 – Fitted with a medium-heavy profile 18”(457mm), 2-stage match grade trigger and telescoping UBR butt stock. This model is suitable for use as a Designated Marksman’s Rifle for point target engagements out to 700m.



R.E.P.R. 16 – Fitted with a medium profile 16”(406mm) barrel, Enhanced Service Fire Control Group (Semi or Select Fire) and telescoping EMOD butt stock, this is configured as a Battle Rifle that can engage point targets out to 600m.



R.E.P.R. 12 – Fitted with a medium profile 12.7”(323mm) barrel, Enhanced Service Fire Control Group (Semi or Select Fire) and telescoping EMOD butt stock, this configuration is intended for use as a heavy caliber Assaulter weapon up to 300m.

Designed for the rigors of military use, the R.E.P.R. series is extremely robust and suited to the demands of field operations without the need for excessive care and maintenance while maintaining a high level of performance.

2.0.1 TECHNICAL DATA:

Caliber	7.62x51mm NATO (.308 Winchester)
Weight (unloaded w/o accessories)	R.E.P.R. 12 - 8.9lbs. (4.03kg) R.E.P.R. 16 - 9.37lbs (4.25kg) R.E.P.R. 18 - 10.5 lbs (4.76kg) R.E.P.R. 20 - 11.17 lbs (5.07kg)
Length (stock collapsed)	R.E.P.R. 12 - 31.3 inches (795mm) R.E.P.R. 16 - 34.5 inches (876mm) R.E.P.R. 18 - 36.4 inches (925mm) R.E.P.R. 20 - 40.5 inches (1029mm)
Barrel Length	R.E.P.R. 12 - 12.7 inches (323mm) R.E.P.R. 16 - 16 inches (406mm) R.E.P.R. 18 - 18 inches (457mm) R.E.P.R. 20 - 20 inches (508mm)
Rifling	6 Lands & Grooves, 1:10" RH Twist
Magazine Capacity	5, 10 or 20 rounds
Trigger Pull (semi)	R.E.P.R. 12 & 16 - 5.05 - 8.0 lbs R.E.P.R. 18 - 3.2-5.0 lbs (1st stage) 0.5-1.5 lbs (2nd stage) R.E.P.R. 20 - 1.3-3.0 lbs (1st stage) 0.5-1.5 lbs (2nd stage)
	5.05 – 8.0 lbs
Sustained rate of fire	50 rounds per minute
Rapid rate of fire	120 rounds per minute
Range	R.E.P.R. 20 – 800 meters R.E.P.R. 18 – 700 meters R.E.P.R. 16 – 600 meters R.E.P.R. 12 – 300 meters R.E.P.R. 20 – 1000 meters R.E.P.R. 18 – 900 meters R.E.P.R. 16 – 800 meters R.E.P.R. 12 – 500 meters

2.1 WEAPON NOMENCLATURE:

2.1.1 R.E.P.R. 16

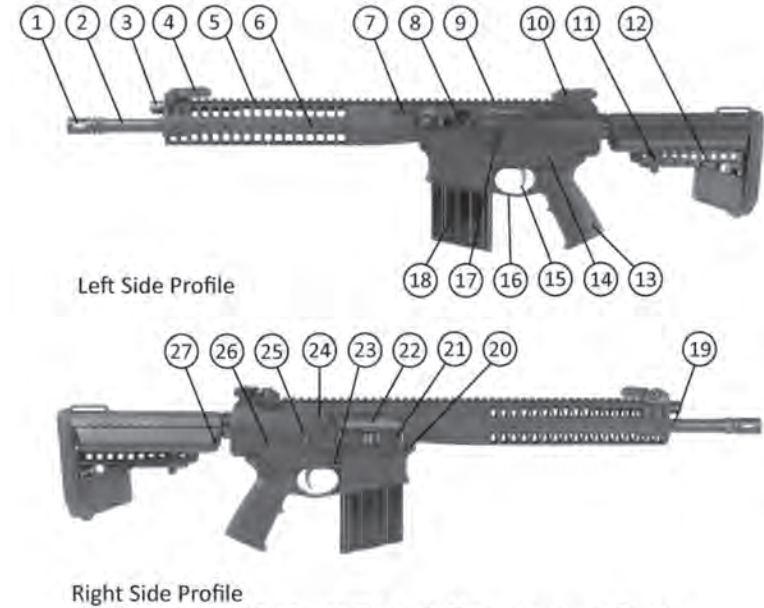

Fig. 2a: R.E.P.R. 16w. EMOD stock - Main Features and Controls

- | | |
|--|-------------------------------------|
| 1. Muzzle | 15. Trigger |
| 2. Barrel | 16. Trigger Guard |
| 3. Gas Regulator Knob | 17. Bolt Catch/Release |
| 4. Front Sight | 18. Magazine |
| 5. Top Rail | 19. Pusher Screw |
| 6. Rail Handguard Body | 20. Front Take Down Pin (Hinge Pin) |
| 7. Rail Base/ Barrel Nut | 21. Ejection Port Cover |
| 8. Cocking Handle Knob/ Forward Assist | 22. Ejection Port |
| 9. Receiver Rail | 23. Magazine Release |
| 10. Rear Sight | 24. Case Deflector |
| 11. Stock Release Lever | 25. Ambidextrous Bolt Catch/Release |
| 12. Storage Compartment | 26. Rear Take Down Pin |
| 13. Pistol Grip | 27. Battery Compartment |
| 14. Selector Lever | |

Items 11,12 and 27 are only applicable to the EMOD stock.

2.1.2 R.E.P.R. 20

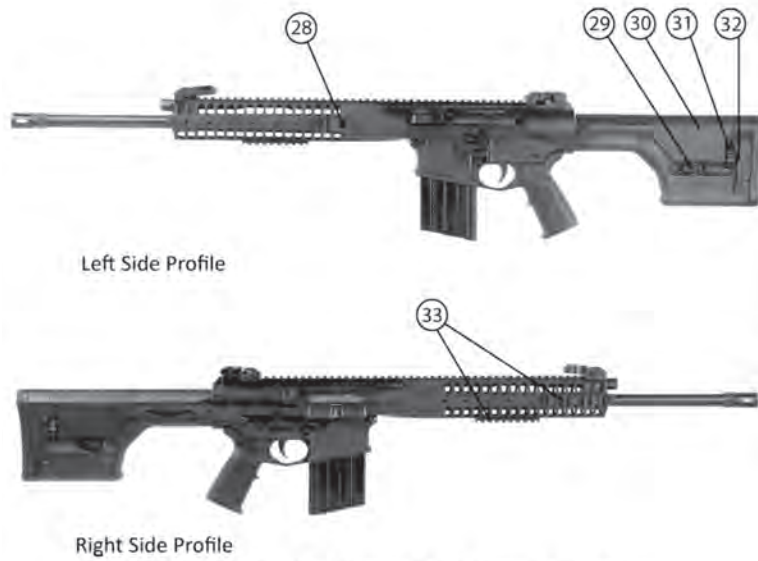

Fig. 2b: R.E.P.R. 20w. PRS stock - Specific Features and Controls

- 28. QD Sling Mount
- 29. Cheek Piece Adjustment
- 30. Cheek Piece
- 31. Length of Pull Adjustment
- 32. Sling Loop
- 33. Configurable Rail Sections

Items 29-32 apply only to PRS stock.

2.1.3 R.E.P.R. 18



Fig. 2c: R.E.P.R. 18 Left and Right Profile Views

2.1.4 R.E.P.R. 12



Fig. 2d: R.E.P.R. 12 Left and Right Profile Views

2.1.5A R.E.P.R. 16 DISASSEMBLED



- R.E.P.R. 16**
 A. Piston Cup
 B. Top Rail
 C. Operating Rod Assy.
 D. Upper Receiver Assy.
 E. Bolt Carrier Group
 F. Lower Receiver Assy.
 G. Magazine

2.1.5B R.E.P.R. 20 DISASSEMBLED





- R.E.P.R. 20**
 A. Piston Cup
 B. Top Rail
 C. Operating Rod Assy.
 D. Upper Receiver Assy.
 E. Bolt Carrier Group
 F. Lower Receiver Assy.
 G. Magazine

2.1.6 OPERATING CONTROLS

2.1.6.1 SELECTOR LEVER (14.)

Located on the left side of the lower receiver, the selector lever functions as the manual safety of the R.E.P.R. and also the fire control selector on select fire weapons. The receiver is marked with pictograms of all three modes,

SAFE		Prevents trigger from releasing the hammer.
SEMI-AUTOMATIC		Allows one shot per pull of the trigger.
AUTOMATIC		Rifle will shoot and load multiple shots until the trigger is released or ammunition runs out.

ALL LWRCI rifles are marked with the AUTOMATIC setting, however it is only functional in a select-fire weapon (Military and Law Enforcement Only). The AUTOMATIC setting cannot be engaged in a semi-automatic weapon.

SAFE can only be engaged when the hammer is cocked by operating the charging handle.

2.1.6.2 TRIGGER (15.)

The Trigger is used to fire the weapon. It is enclosed by the Trigger Guard. The R.E.P.R. 18 is equipped with a 2-stage trigger. It has a heavier and longer 1st stage (approx. 4lbs pull) and a lighter, crisp 2nd stage break (approx. 1 lb. pull). The R.E.P.R. 20 is equipped with an adjustable, 2-stage trigger. Please follow the instructions, provided by Geissele Automatics, for adjusting the trigger.



CAUTION: Adjusting the trigger to a very low pull weight can cause a significant safety issue on a self-loading rifle. LWRCI does not suggest you adjust the trigger. It has been factory tuned on a precision jig.



CAUTION: LWRCI only advocates the use of the fire control group supplied with your weapon. They have been thoroughly tested through drop testing and environmental testing to ensure safe use in the field. There are single-stage match triggers on the market that, in our opinion, are unsafe for use on an operational firearm.



CAUTION: Installation of aftermarket accessories that extend into the trigger guard area of the weapon is discouraged and could result in a negligent discharge.

2.1.6.3 CHARGING HANDLE (8.)

The Charging Handle on the left side of the R.E.P.R. is used to charge the weapon and/or retract the Bolt Carrier Group. It is non-reciprocating. A Forward Assist or Silent Bolt Closure is built into the Charging Handle and is activated by depressing the Charging Handle Knob and pushing forward.

NOTE: Depressing the Charging Handle knob while charging a R.E.P.R. will prevent the Bolt carrier Group from retracting fully and potentially cause a misfeed.

2.1.6.4 BOLT CATCH/RELEASE (17. AND 25.)

The R.E.P.R. is equipped with ambidextrous bolt catch/release

controls on both left (Fig 17) and right (Fig 25) sides of the Lower Receiver. They are used to release the Bolt Carrier Group from the locked open position or to lock the Bolt Carrier Group back when there is a filled magazine or no magazine loaded in the Magazine Well. This is done by depressing the lower portion of either Bolt Catch/Release while retracting the Charging Handle all the way to the rear. Return the Charging Handle to the forward position after.

 **CAUTION:** Releasing the Bolt Catch with a loaded Magazine will load the weapon.

2.1.6.5 GAS REGULATOR KNOB



The Gas Regulator adjusts the volume of gas directed into the piston. There are 4 detent positions, **Closed** (marked **C**), **Suppressed** (marked **S**), **Normal** (marked **N**) and **Adverse** (marked **A**). The marking that is at 12 o'clock, nearest the top rail and furthest from

the barrel indicates the setting in use. (See Fig.2j) The shape of the regulator is an irregular ellipse to allow the shooter to determine the active position by touch. Learn the shape of the regulator by remembering the protuberant feature of the knob in relation to a landmark on the weapon.

 **CAUTION:** The gas regulator and gas block will be one of the hottest parts of the weapon during firing. The regulator knob CAN BE HOT ENOUGH TO BURN YOUR HAND.

Closed setting cuts off all gas from the piston system so the weapon will not cycle when fired. This setting is typically used when it is necessary to "palm" or retain expended cartridges and/or when absolute noise control is a necessity by eliminating the sound of the action cycling. Typically this is used with subsonic ammunition. This setting should be used sparingly as your regulator will become hard to turn if you fire extensively in closed

 **CAUTION:** Always check to make sure the gas regulator is on the correct setting before operational use.

Suppressed setting is used in conjunction with Sound Suppressors to reduce gas backpressure caused by the suppressor. Some suppressors create more backpressure than others and therefore you may not need to use the suppressed setting with your particular suppressor. If on the Suppressed setting your weapon demonstrates signs of being under-gassed (failure to extract, failure to lock back on an empty magazine) then run your rifle on the N-Normal setting.

NOTE: Always follow the instructions supplied by the suppressor manufacturer for installing the suppressor and suppressor mount.

Normal setting is the default setting for non-suppressed operation. R.E.P.R.s are tuned for operation with match grade ammunition with heavier weight bullets like M118LR or Federal Gold Medal Match 168gr. Ejection with these loads should be at the 4 o'clock position (with muzzle at 12 o'clock). With higher pressure loads, the ejection pattern should shift to the 2-3 o'clock position. This indicates that the bolt carrier velocity is higher than optimal which may increase the possibility of a bolt-over-base stoppage.

Adverse setting is only used when the weapon is operating sluggishly due to extreme and/or very low temperature and/or underpowered ammunition.



When you first shoot your REPR, use the gas block tool to rotate while the weapon is still warm. Work through each of the settings several times then lubricate. This will greatly reduce the likelihood that your regulator will stick in the future.

These apply to the EMOD stock on the R.E.P.R. 12 & 16 only

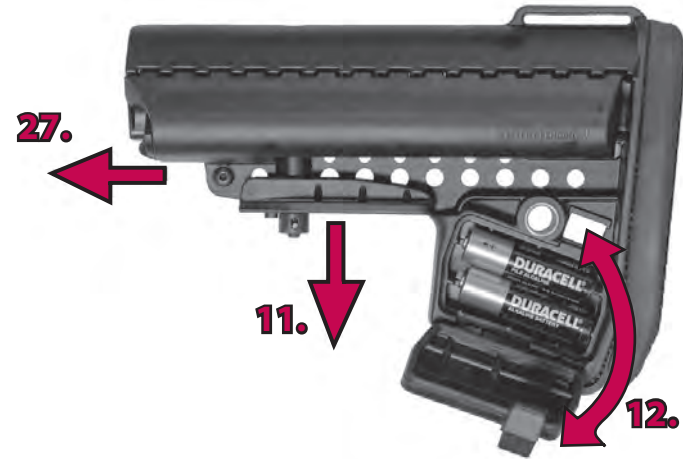

2.1.6.6 STOCK CATCH LEVER (11.)

This Lever is is depressed to allow the EMOD stock to move between detent positions. Depress the lever on either side of the ventral rib and push/pull the stock

2.1.6.6 STORAGE COMPARTMENT (12.)

Depress the catch to open the storage compartment.

2.1.6.7 BATTERY STORAGE (27.)

Rotate tab while pulling on the storage cap to remove it. Press back into place. Holds 4x CR123A batteries each.

These apply to the PRS stock on the R.E.P.R. 20 only



2.1.6.8 CHEEK ADJUSTMENT (29.)

This knob is used to raise or lower the height of the Cheek Piece (30). Facing the left side of the weapon with the stock to the right, the knob is rotated to the left to raise the Cheek Piece and the right to lower it.

2.1.6.9 LENGTH OF PULL ADJUSTMENT (31.)

This feature allows the user to optimize your length of pull (buttstock length) ensuring perfect eye relief with your optic and comfort in an optimal shooting position.

The stock should be adjusted to be firm against the shoulder pocket and without neck strain while using the optic. A properly adjusted stock will reduce perceived recoil and enable faster and more accurate follow up shots.

2.1.6.10 EJECTION PORT COVER (21.)

The ejection port cover is spring loaded with a closing detent. It will automatically open when the Bolt Carrier cycles and remain open until closed manually. The ejection port cover should always be manually closed after a course of fire and the situation is assessed as non-threatening.

2.1.6.11 PUSHER SCREWS (19.)

At the front of the Rail Handguard Body (6.) are the pair of Pusher Screws that keep the Top Rail (5.) correctly indexed to the Rail Handguard Body. They are captive to the Rail Handguard Body and will not fall out. The knurled head allows them to be finger tightened and a slot allows the use of a cartridge rim or coin to torque them tight. Never use excessive force to tighten these screws. There are high temperature O-rings that when compressed will prevent the screws from vibrating loose.

These apply to the UBR stock on the R.E.P.R. 18 only



2.1.6.12 STOCK RELEASE LEVER (34.)

The length of the UBR stock is adjusted by pulling back on this lever and then moving the lower part of the stock to the desired location. Release to lock.

2.1.6.13 STORAGE COMPARTMENT (35.)

Depress the latch to open the storage compartment.



**SAFETY INFORMATION
AND PROCEDURES**

READ THIS MANUAL COMPLETELY PRIOR TO OPERATING YOUR WEAPON.

THE FOUR FIREARMS SAFETY RULES

1. Treat every weapon as if it were loaded at all times.
2. Never point your weapon at anything you don't intend to shoot.
3. Keep your finger straight and off the trigger until you intend to fire.
4. Keep your weapon on safe until you intend to shoot.

3.1 GENERAL SAFETY PROCEDURES:

3.1.1 Whenever handling any weapon, point the muzzle in a safe direction as soon as you pick the weapon up, then CLEAR the weapon. See 3.3.1 to 3.3.5. Ensure chamber is clear.

3.1.2 Whenever handing your weapon to another person, clear the weapon first and hand it over with the bolt locked to the rear by the bolt catch. When receiving a weapon from another person insist that they clear it and lock the bolt to the rear before accepting the weapon. Check the chamber to ensure the weapon is clear when you accept the weapon.

3.1.3 Always ensure you are firing the correct caliber ammunition through your weapon. To ensure proper function and safety LWRCI recommends using only factory loaded ammunition that complies with the Sporting Arms and Ammunition Manufacturer's Institute (SAAMI), Commission Internationale Permanente pour l'Épreuve des Armes à Feu Portatives (CIP), NATO, or ammunition loaded to U.S. Military specifications for the weapon. LWRCI doesn't guarantee your weapon's safety or performance when utilizing re-loaded or surplus ammunition.

3.1.4 Check your weapon's bore to ensure it is free from obstructions before firing. In the event that the weapon is dropped or the muzzle touches the ground, unload and ensure the weapon bore is free from obstruction. If it is dark and the tactical situation permits, use a flashlight to ensure there is not an obstruction. If the tactical situation calls for light discipline, drop a cleaning rod through the bore to ensure there is no obstruction.

3.1.5 Prior to firing your weapon, know your intended target and what lies beyond. Ensure that there is an adequate backstop or open space free from people or any other unintended targets prior to shooting. Never shoot at water or hard objects as ricochets will occur and pose a safety hazard to property, people in the vicinity, or the shooter.

3.1.6 Be aware of where the weapon muzzle is pointed at all times and NEVER flag (point your muzzle at) any person or unintended target regardless of the status of the weapon. When not being carried on the range your weapon should be placed in Range Safe condition with the muzzle facing down range ejection port up, the bolt locked to the rear and selector on safe. No weapon should be handled regardless of status while people are down range. Observe all rules of the range you are firing on.

3.1.7 Weapons should be stored unloaded, and in a locked case or other secure area.

3.1.8 Always use hearing and eye protection when shooting any firearm.

3.1.9 Be familiar with your weapon and its features, controls and operating procedures prior to shooting.

3.2 WEAPON CONDITIONS:

Condition 4: Bolt forward on an empty chamber, ejection port cover closed, no magazine inserted, and selector lever on fire (will not engage safe). See 3.3

Condition 3: Bolt forward on an empty chamber, ejection port cover closed, magazine inserted, and selector lever on fire (will not engage safe).

Condition 2: Not applicable.

Condition 1: Bolt forward with a round chambered, ejection port cover closed, magazine inserted, and selector lever on safe.

Range Safe: Bolt locked to the rear, ejection port cover open, no magazine inserted, and selector lever on safe.

3.3 CLEARING YOUR WEAPON – UNLOADING:

3.3.1 Ensure the muzzle is pointed in a safe direction at all times and through the course of unloading the weapon.

3.3.2 Remove the Magazine (if present) by depressing the Magazine Release and either allowing it to drop free or pulling it out.

3.3.3 Depress and hold the base of the Bolt Catch with trigger finger.

3.3.4 Grasp the Charging Handle firmly with the support hand and pull firmly all the way to the rear. Release the Charging Handle. The bolt carrier should remain locked back.

3.3.5 Roll the rifle counterclockwise to visually confirm that there is no round or casing in the chamber. If light conditions are low, physically inspect chamber.

3.3.6 Upon confirmation that the chamber is clear, depress the paddle of the Bolt Catch. The bolt carrier should move forward and go into battery.

3.3.7 While pointing the weapon in a safe direction, depress the Trigger to render it inert. Your Selector Lever should not go to safe, indicating that the hammer is no longer cocked.

3.3.8 Close the Ejection Port Cover. Your rifle is now in Condition 4 and ready for administrative handling.



CAUTION: Do not depend on the fact that no chambered round was ejected on clearing. You can still have a live round in the chamber that did not extract/eject because your extractor was broken, or if the case rim was ripped through by the extractor. VISUALLY AND PHYSICALLY inspect the chamber to ensure it is clear.

3.4 PRE-FIRE FUNCTION TEST:

The User should always complete a pre-fire function test of the action and fire control group before using the weapon and any time the weapon has been disassembled and reassembled.

3.4a Semi-Automatic Mode

3.4.1 Ensure weapon is CLEAR (see 3.3) and in Condition 4 prior to performing a function test.

3.4.2 Insert an empty Magazine fully into the Magazine Well and pull downward. The Magazine should remain locked into the magazine well.

3.4.3 Grasp the Charging Handle and pull it firmly to the rear. The bolt carrier should lock to the rear. Return the charging handle to its forward and locked position by pushing it forward.

3.4.4 Depress the magazine release. The magazine should eject from the magazine well and the bolt carrier should remain locked to the rear.

3.4.5 Depress the top serrated portion of the bolt catch. The bolt carrier should spring fully forward and lock into battery.

3.4.6 With the selector lever on "SAFE" depress the trigger. The hammer should not fall.

3.4.7 Rotate the selector lever to "SEMI" and depress the trigger. The hammer should fall.

3.4.8 Charge the weapon by grasping the charging handle, pulling it firmly to the rear and releasing. Depress and hold the trigger. The hammer should fall.

3.4.9 Continue holding the trigger while charging the weapon again. Release the trigger as slowly as possible and you should hear a click as the disconnecter disengages. The hammer should remain cocked.

3.4B AUTOMATIC MODE

3.4.10 Place the selector lever on "AUTO" Depress and hold the trigger. The hammer should fall.

3.4.11 Continue to hold the trigger and charge the weapon 2-3 times. Each time the bolt should go forward and the hammer should fall. Release the trigger.

3.4.12 This completes the function check. Make weapon Condition 4.

3.5 PRE-FIRE INSPECTION (PFI)

Perform the following inspection prior to each firing session. Start your PFI with your weapon in Condition 4.

3.5.1 Break the weapon down "shotgun style" by pulling out the Take Down Pin (26.) and pivoting the Lower Receiver down from the Upper Receiver.

3.5.2 Remove the Bolt Carrier Group by pulling the Charging Handle back all the way and grasping the rear of the Bolt Carrier.

3.5.3 Inspect the Bolt and Bolt carrier ensuring the following; the Bolt Cam Pin is correctly installed with the arrow facing forward; if applicable, the Firing Pin Retainer is fully seated in its hole. Ensure the firing pin hole is unobstructed and the Firing Pin is properly installed. Tap the bottom of the Bolt Carrier firmly against the palm of your hand. The Firing Pin should stay in place.

3.5.4 Visually inspect the bore of the weapon to ensure it is unobstructed. In low light conditions physically inspect the bore by passing a cleaning rod through it.

3.5.5 Re-assemble the weapon inserting the Bolt Carrier Group. Pivot the Lower Receiver back up to the Upper Receiver and press in the Rear Take Down Pin.

3.5.6 Ensure that the Gas Regulator is in the appropriate detent position as dictated by use.

3.5.7 Inspect the Magazines for the following: Ensure the Magazines are clean and not dented (particularly the feed lips). Ensure the Magazine Follower moves freely within the magazine body and returns under its own spring tension without binding. Do NOT oil or otherwise lubricate magazines. Only use Magazines recommended by LWRCI.

3.5.8 Inspect the ammunition prior to firing. Ensure ammunition is factory manufactured in compliance with SAAMI, CIP and/or U.S. MIL-Spec/STANAG specifications. Ensure ammunition is the correct caliber for the weapon. Ensure ammunition is clean. Do not oil or otherwise lubricate ammunition. Do not overload magazines.

3.5.9 Put the weapon in Condition 4 or Range Safe status.



OPERATION

4.0.1 Choice of Ammunition

Although the R.E.P.R. is designed to cycle with a broad spectrum of ammunition, it is optimized for use with heavy bullet loads. With a 1-in-10 inch rate of rifling, the barrels are designed to stabilize heavy bullets up to 190 grains.

The design ammunition is M118LR Match ammunition with the 175 grain Sierra Match King bullet. The factory recommends the use of this ammunition or similar loads such as the Federal Gold Medal Match (GMM) and Black Hills 175gr Match. It is suggested to use ammunition with bullets heavier than 168 grains for peak accuracy. M80 Ball and equivalent will not realize the true accuracy potential of the R.E.P.R. It is not suggested you use M118LR or any long range load in SBR's. The slow burn rate of these propellant is not optimized in short barrels. Reliability and velocity will be adversely affected

4.0.2 Magazines

The R.E.P.R. was designed to use common magazines with other 7.62x51mm NATO rifles currently in use. However, the R.E.P.R. is optimized and will perform best with the supplied Magpul LR-20 magazine. Additional magazines are available from LWRCI.

4.1 LOADING A MAGAZINE

- 4.1.1 Grasp the Magazine firmly in your support hand.
- 4.1.2 Push the round under the magazine feed lips. The base of the cartridge should be all the way back against the back of the magazine.
- 4.1.3 Repeat until the magazine is filled. DO NOT OVERFILL the magazine.

4.2 LOADING A WEAPON IN CONDITION 4

Starting with the weapon in Condition 4:

- 4.2.1 Insert a loaded magazine firmly into the Magazine Well. Ensure the magazine is fully seated by tugging on it.
- 4.2.2 Charge the weapon by firmly pulling the charging handle to the rear and releasing it ("slingshot" method).
- 4.2.3 Rotate the selector to "SAFE". If not immediately firing the weapon close the ejection port cover. The Weapon is now in Condition 1.

4.3 FIRING IN SEMI-AUTOMATIC MODE

Starting with a weapon in Condition 1:

- 4.3.1 Bring Weapon to the "Ready" position.
- 4.3.2 Acquire and Aim at the intended Target.
- 4.3.3 Put Selector to "SEMI".
- 4.3.4 Depress trigger with a deliberate squeezing motion of the strong hand index finger to fire individual shots. Repeat until target is neutralized.
- 4.3.5 Scan and assess for threats or targets.
- 4.3.6 Put Selector to "SAFE".
- 4.3.7 Close Ejection Port Door.

4.4 Firing in Automatic Mode (only in Select Fire weapons)
Starting with a weapon in Condition 1:



CAUTION: Auto should only be considered operationally if the user has had sufficient training and practice on this setting

- 4.4.1** Bring Weapon to the “Ready” position.
- 4.4.2** Acquire and Aim at the intended Target.
- 4.4.3** Put Selector to “AUTO”.
- 4.4.4** Depress trigger with a deliberate squeezing motion of the strong hand index finger to fire bursts. Release trigger to discontinue burst. 3-5 round bursts are optimal. Repeat until target is neutralized.
- 4.4.5** Scan and assess for threats or targets.
- 4.4.6.** Set Selector to “SAFE”.
- 4.4.7.** Close Ejection Port Door.

4.5 RELOADING FROM BOLT LOCK

When the Magazine is out of ammunition, the Bolt Catch is automatically engaged. The Bolt Carrier Group is held open. The weapon will not fire. To Reload:

- 4.5.1** Depress the Magazine Release. Pull the Magazine out of the magazine well and allow it to fall to the ground.
- 4.5.2** Retrieve a loaded Magazine with your support hand.

4.5.3 Insert loaded Magazine into Magazine Well. Ensure the magazine is fully seated by tugging on it.

4.5.4 Depress the Bolt Catch from either side of the weapon. This will allow the Bolt Carrier to go into battery and chamber a round. Weapon is now in Condition 1.

4.5.5 Scan and assess for threats or targets. Re-engage as necessary.

4.5.6 Set Selector to “SAFE”.

4.5.7 Close Ejection Port Door.

4.6 TACTICAL RELOAD

A tactical reload is carried out during a lull in combat to keep the weapon topped up with ammunition. It is conducted from Condition 1:

- 4.6.1** Retrieve a loaded Magazine with your support hand. Grasp the base of it with thumb and index finger.
- 4.6.2** Grasp partially empty Magazine between 2 digits of support hand. Depress the Magazine Release. Remove the Magazine by hand.
- 4.6.3** Insert loaded Magazine into Magazine Well. Ensure the magazine is fully seated by tugging on it.
- 4.6.4** Stow partially empty magazine appropriately.
- 4.6.5** Scan and assess for threats or targets.
- 4.6.7** Close Ejection Port Door.

4.7 OPERATING CYCLE

The following describes the operating cycle of the R.E.P.R. in semi-automatic mode.

Firing	When the Trigger is depressed, the sear is disengaged from the Hammer allowing the hammer to be driven by the Hammer spring to strike the Firing Pin. The Firing Pin strikes the primer, firing the chambered round.
Unlocking	Propellant gasses are tapped off at the gas port and travel through the gas block to the nozzle. This gas drives the piston cup back from the nozzle, in turn driving the operating rod to strike the carrier key. This initiates the rearward movement (recoil stroke) of the Bolt Carrier Group. As the Bolt Carrier travels to the rear, the Cam Pin rotates the Bolt, thus unlocking it from the barrel extension.
Extraction	As the Bolt Carrier Group continues through the recoil stroke the expended cartridge is drawn from the chamber by the extractor.
Ejection	Once the expended cartridge is clear of the chamber it is ejected from the weapon by the spring loaded Ejector.
Cocking	<p>Semi -As the Bolt Carrier Group continues to the rear it cocks the Hammer which is initially retained by the Disconnecter. As the shooter disengages the trigger, the Disconnecter releases the hammer allowing it to be captured by the Trigger (this is known as Reset).</p> <p>Auto - As the bolt carrier group continues to the rear it cocks the hammer which is retained by the auto sear. Concurrently the rear of the bolt carrier will trip the auto sear releasing the hammer and firing the round. When the trigger is depressed and held, the weapon will cycle continuously through the firing sequence until the trigger is released or the magazine is depleted. When the user releases the trigger, the hammer is caught by the hammer/trigger engagement surface and does not allow the weapon to fire again until the trigger is pulled.</p>

Feeding	The recoil stroke concludes when the Buffer halts the Bolt Carrier Group. The Recoil Spring, compressed during the recoil stroke, drives the bolt carrier group forward commencing the counter-recoil stroke. As the Bolt Carrier returns forward the next round is stripped from the top of the Magazine and directed into the chamber by the feed lips of the magazine and the feed ramps
Chambering	As the bolt carrier group continues the counter-recoil stroke the round is seated in the chamber.
Locking	As the bolt carrier group completes the counter recoil stroke the bolt rotates, locking into the barrel extension. The bolt carrier group is now again in battery.



IMMEDIATE AND REMEDIAL ACTIONS

5.1 IMMEDIATE ACTION

Immediate Action is defined as the prompt action taken by the operator to reduce a stoppage without investigating the cause. A stoppage is defined as any interruption in the operating cycle. It is suggested to transition to a secondary weapon if cover is not available, or if the situation permits perform the following:

- 5.1.1 Keep the weapon shouldered and in the ready position pointed downrange.
- 5.1.2 Ensure the magazine is fully seated by pushing the magazine up into the mag well and then tugging firmly down to ensure it is securely engaged.
- 5.1.3 Pull the charging handle to the rear and release in a slingshot motion. DO NOT ride the charging handle forward.
- 5.1.4 Re-engage the target.
- 5.1.5 If the weapon does not eject a casing or live round apply Remedial Action.

5.2 REMEDIAL ACTION

Remedial Action is defined as the actions taken by the operator to remedy a Malfunction. A Malfunction is defined as a failure of the weapon to operate as designed. A simple way to remember the steps of a remedial action is to simply "Unload" the weapon, and "Reload" the weapon once the weapon is clear.

- 5.2.1 Attempt to set the Selector Lever to "SAFE".

- 5.2.2** Lock the Bolt Carrier Group to the rear by depressing the bottom segment of the Bolt Catch and pulling the Charging Handle to the rear. Return the Charging Handle to the forward position.
- 5.2.3** Remove and discard the Magazine.
- 5.2.4** Roll the rifle 60 degrees counter-clockwise to visually inspect the chamber for obstructions.
- 5.2.5** Shake or attempt to clear any stoppage via the Magwell or Ejection Port.
- 5.2.6** Check Gas Regulator to ensure it is at an appropriate setting.
- 5.2.7** Release the Bolt Catch and manipulate the Charging Handle at least three (3) times to ensure the action is functioning properly.
- 5.2.8** Make the weapon Condition 1 weapon and continue the mission.



MAINTENANCE

Proper maintenance of a weapon requires not only immediate pre and post firing cleaning but also the replacement of consumable parts to ensure 100% of the reliability and accuracy of the product throughout its lifetime. Keep an accurate log of every round fired through the weapon. Even writing down an estimate of the number of rounds fired on a given day will help you perform scheduled maintenance on the system.

This is an operators manual and does not cover replacement of parts outside those that can be replaced on a Detailed Strip (as described in section 6.2 of this manual). It is encouraged that only a certified armorer should disassemble and replace parts beyond those removed during a field strip.

6.1 DISASSEMBLY (FIELD STRIP)

Frequency: The weapon should be disassembled to its major groups and assemblies when conducting Routine Operator Level Maintenance (as determined by unit). For convenience the Upper Receiver can remain connected to the Lower Receiver (weapon broken down “shotgun style”) during Routine Operator Level Maintenance.

***TIP:** Lay your parts out from left to right in the sequence they were removed from the weapon so upon reassembly, you just work right to left. This procedure will also be useful if you have to strip and reassemble the weapon in the dark.*

The sequence is as follows:

6.1.1 Clear the weapon (refer to Section 3.3 of this manual) and ensure the weapon is Condition 4. Your Bolt Carrier must be in battery.

6.1.2. (Fig. 6a) Pull out the Take Down Pin by pushing from the left side of the Lower Receiver to start the pin moving then pull out from the right. A dowel or bullet tip can be helpful. The pin detent will be stiff on a new rifle. This will get easier as you use and disassemble your R.E.P.R.



Fig. 6A: Pushing in the Take Down Pin

(Fig. 6a) Pull the pin from the right as far as it goes. The pin will remain captive. This pin releases the back end of the upper receiver from the lower receiver.

6.1.3 (Fig. 6b) Pivot the Lower Receiver until it is 90° to the Upper Receiver. Pull out the front take down pin and disconnect the upper from the lower completely.



Fig. 6B: Pivot apart the receivers

6.1.4 Pull the Charging Handle back all the way and grasp the rear of the Bolt Carrier. Remove it from the receiver. Return the Charging Handle to the forward position

6.1.5 Remove the Buffer and Buffer/Recoil Spring by depressing the buffer detent (Fig. 6c) Pull the buffer and spring from the lower receiver (Fig. 6d).

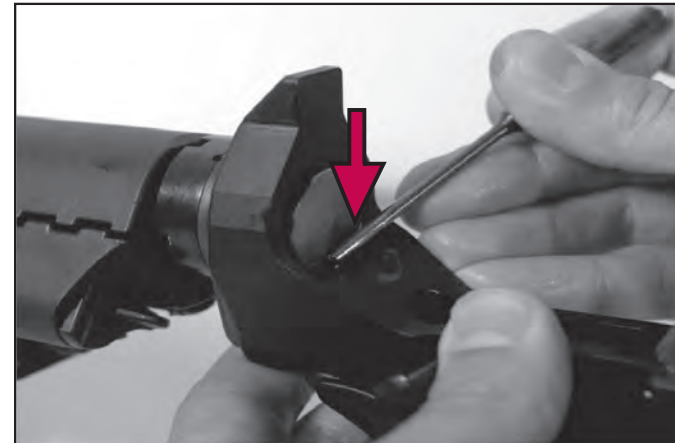

Fig. 6C: Depress the Buffer Detent

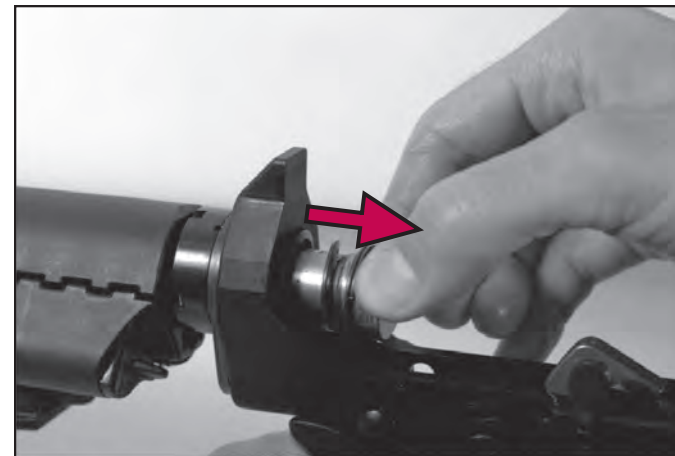

Fig. 6D: Remove Recoil Buffer and Recoil Spring

6.1.6 Remove the Recoil Buffer from the Recoil Spring. The R.E.P.R. is now Field Stripped.

6.2 DETAILED DISASSEMBLY

This level of disassembly is for Detailed Operator Level Maintenance of the R.E.P.R. Care must be taken to ensure that small parts are not lost. The use of a cloth or tarpaulin to catch them is encouraged. Further disassembly is not required for operator authorized maintenance and should only be performed by higher echelon maintenance personnel.

6.2.1 Clear and Field Strip the weapon by following the instructions in the previous section.

6.2.2 Bolt Carrier Disassembly

6.2.2a (Fig. 6G) Remove the Firing Pin Retaining Pin from the Bolt Carrier.

6.2.2b (Fig. 6H) Turn the carrier so the Bolt is facing upward and tap against a surface to remove the Firing Pin.



DUPLICATE PHOTO

6.2.2c Ensure the Bolt is retracted into the Bolt Carrier and rotate the Bolt Cam-Pin 90° counter-clockwise. Pull to remove the Bolt Cam Pin

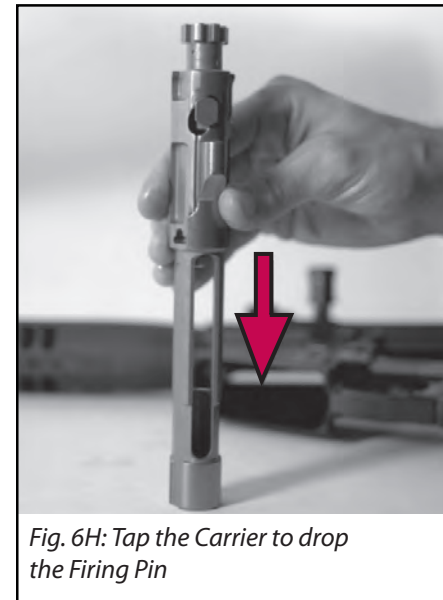
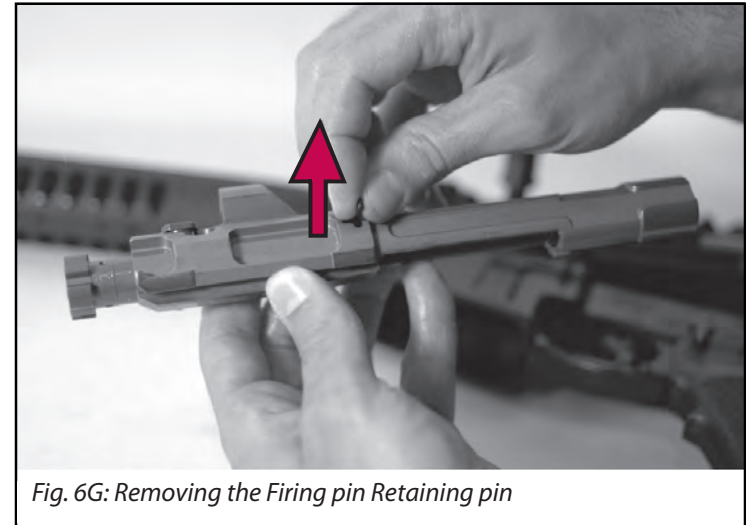

6.2.2c Once the Cam Pin is removed, pull forward on the Bolt Assembly to remove it from the Carrier.

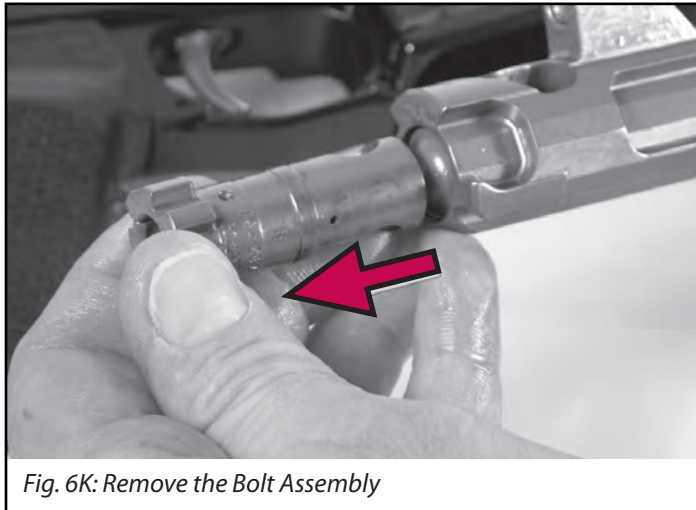

6.2.3 Bolt Disassembly

At the Operator level, no further disassembly of the bolt beyond removing the Extractor is necessary.



6.2.3a (Fig. 6m) Utilize the Firing Pin to push the Extractor Pin and start it out of the bolt.

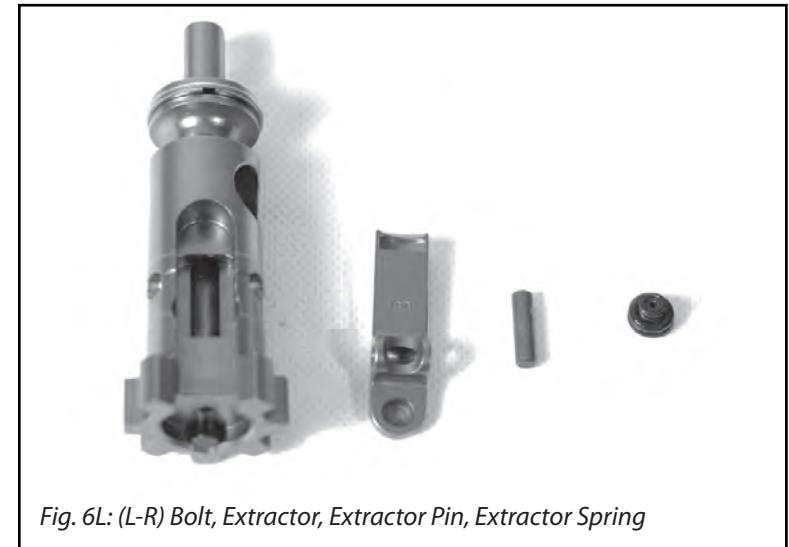

6.2.3b Grasp the pin from the opposite side and remove it. Turn the Bolt over and tap the Extractor out into your palm. Be sure not to lose the extractor springs and o-ring. See Fig. 6L for a description of the parts.

6.2.4 Upper Receiver Group Disassembly

Start from a Field Strip condition. Pull out the Forward Take-down Pin to its stop. Start by pushing the pin from the left side of the receiver. Then pull from the right. Separate the upper and lower receiver.

6.2.4a (Fig. 6n) Remove the Top Rail by loosening the two Pusher Screws and pushing the upper rail forward (Fig. 6p) then lift up (Fig. 6q) and remove.

***NOTE:** The two Pusher Screws are captive and are not supposed to come free from the Rail handguard Body.*

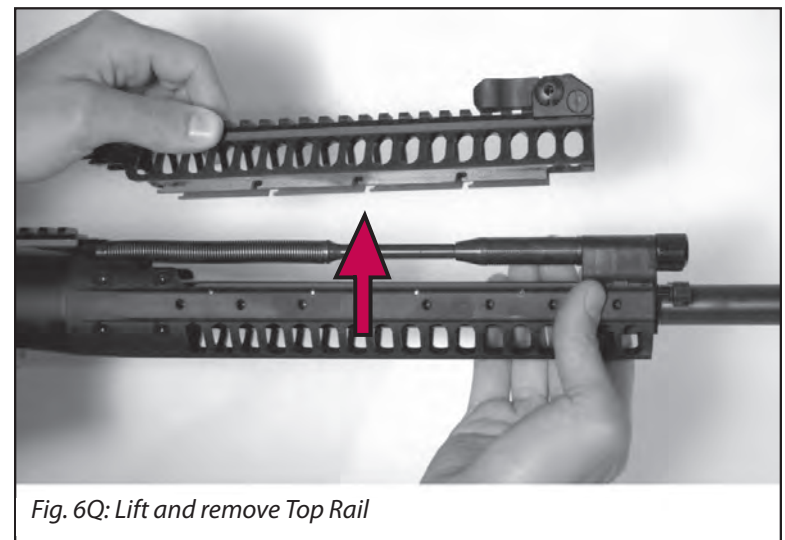
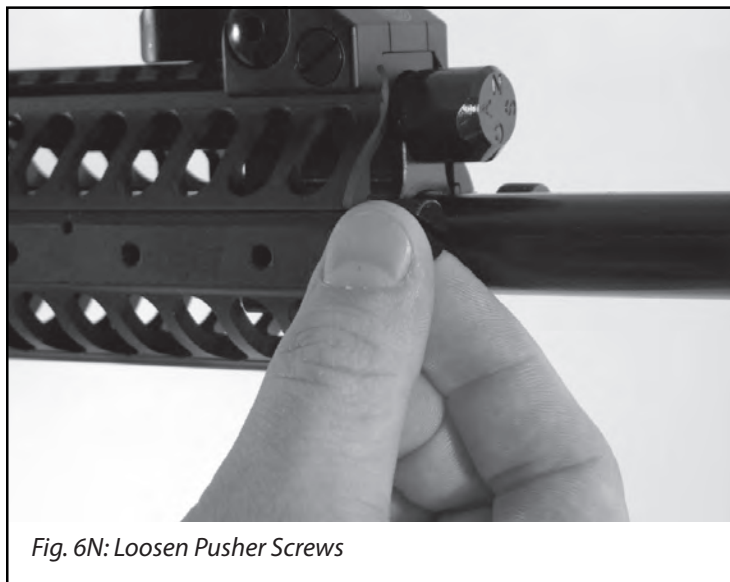

6.2.5 Piston Operating Group Disassembly

6.2.5a To disassemble the Piston Operating Group assembly, grasp the front of the operating rod and pull firmly to the rear compressing the piston spring while pulling forward on the Piston Cup (Fig. 6r). Ensure to pull it straight back into the receiver or it will bind. The front of the operating rod will disengage from the piston cup.

NOTE: If disassembling only the gas piston components on an otherwise assembled rifle, lock the bolt to the rear while disassembling or assembling the gas piston components to relieve the recoil spring resistance.

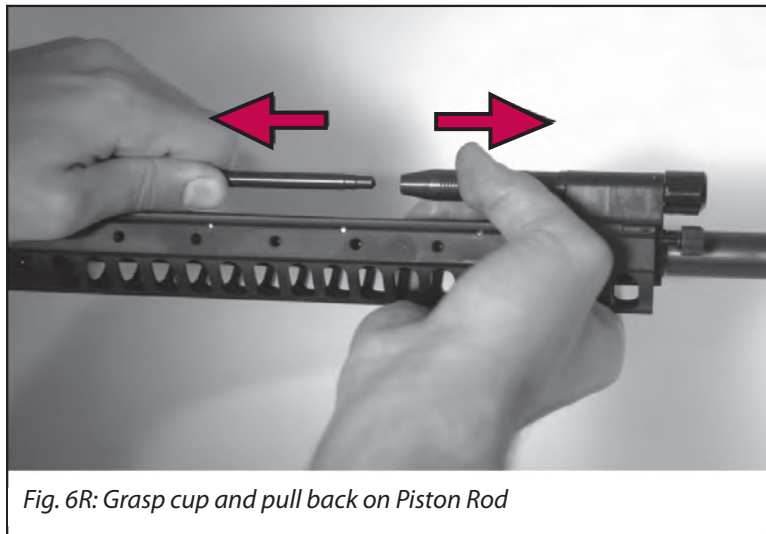

Fig. 6R: Grasp cup and pull back on Piston Rod

6.2.5b Lift out the front of the operating rod assembly and pull it forward then away from the receiver. (Fig. 6s)

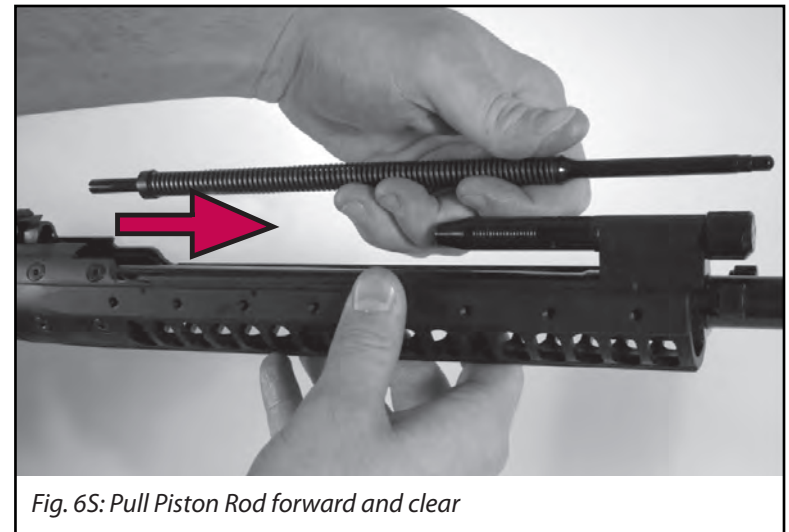

Fig. 6S: Pull Piston Rod forward and clear

6.2.5c Pull the piston cup to the rear and off of the nozzle. This completes detailed disassembly.

6.3 ASSEMBLY

Assembly of the R.E.P.R. series is accomplished by reversing the disassembly steps. During reassembly take note of the following:

6.3.1 When reinstalling the Operating Rod Assembly, rotate the Assembly until it fully seats in the Piston Cup.

6.3.2 When reinstalling the Buffer and Buffer Spring, push the Buffer fully past the buffer detent and ensure it is captured behind the detent.

6.3.3 When reinstalling the Extractor, line up the holes by pressing firmly on the center of the Extractor while reinstalling the extractor pin.

6.3.4 While reinstalling the Firing Pin Retaining Pin ensure the Firing Pin is fully forward and the Firing Pin Retaining Pin is installed from left to right when looking from the rear of the weapon. While Bolt is pushed rearward into Carrier, push end of Firing Pin toward front of Bolt and ensure it protrudes through the face of the Bolt.

6.3.5 When reinstalling the Bolt Carrier Group into Upper Receiver, ensure that the Bolt is fully extended.

6.3.6 When closing the Upper and Lower Receiver, pivot the Lower Receiver to the Upper receiver until contact is made. Then push the Rear Take Down Pin all the way into the Lower Receiver. It may be necessary to push the Upper and Lower Receivers together to enable this.

6.4 ROUTINE OPERATOR'S MAINTENANCE:

Perform routine maintenance after each firing session or once daily while operating in normal field conditions. Ensure weapon is clear prior to performing any maintenance. When punching the weapon's bore pass the cleaning rod through the chamber end towards the muzzle. Otherwise the muzzle may be damaged and degrade accuracy.

6.4.1 Field-strip the weapon as detailed in Section 6.1.

6.4.2 Clean bore by punching first with a patch saturated in Simple Green, SLIP 2000 Carbon Killer or approved solvent. Punch bore with bore brush several times. Punch with a dry patch to remove carbon residue and cleaning solvent.

NOTE: If you see a degradation in accuracy clean bore using a copper solvent per solvent manufacturer's instructions.

6.4.3 Check for cleanliness by punching with a clean patch. If the patch does not come out clean, repeat steps 6.4.2 until it does.

6.4.4 Wipe Bolt Carrier, Charging Handle, interior of Upper Receiver, Buffer and Buffer Spring with a cloth (slightly dampened with cleaning solvent if available).

6.4.5 Scrub the face of the bolt with a GP brush dipped in cleaning solvent or CLP. Thoroughly wipe away any remaining cleaning solvent or CLP with a rag.

6.4.6 Apply a light coat of lubricant to the interior of the upper receiver, buffer spring, compensator and ejection port cover.

6.4.7 Apply point lubricant to the Extractor, Bolt Cam Pin, Hammer pivot point, and Trigger pivot point, Charging Handle Knob, Bolt Catch, and Carrier sear. (NOTE: Do not lubricate the face of the bolt.)

6.4.8 Reassemble weapon and perform functions check as detailed in Section 3.4 and 3.5.

6.5 DETAILED OPERATOR'S MAINTENANCE

Perform Detailed Maintenance every 2,000 rounds or once weekly while operating in normal field conditions. Ensure weapon is clear prior to performing any maintenance.

6.5.1 Detail Disassemble weapon as described in Section 6.2.

6.5.2 Perform Routine Maintenance as detailed in the previous section.

6.5.3 Scrub extractor with GP brush dipped in cleaning solvent or CLP. Pay particular attention to remove any built up brass deposits in the extractor groove. Thoroughly wipe away any remaining cleaning solvent or CLP with a rag.

6.5.4 Scrub Bolt Carrier, Bolt Body, Firing Pin and interior of the Upper Receiver with GP brush dipped in cleaning solvent or CLP. Punch firing pin hole and firing pin cavity with a pipe cleaner. Thoroughly wipe away any remaining cleaning solvent or CLP with a rag. Apply a moderate coat of lubricant to the inside of the Bolt Carrier where the bolt installs. Apply point lubrication to the Extractor where the pin installs and the Bolt Cam Pin when it is installed. Apply a light coat of lubricant to the interior of the upper receiver prior to re-installing the Bolt Carrier Group.

6.5.5 Scrub Gas Piston Nozzle with a dry brass wire brush. Wipe away any remaining carbon residue with a rag and cleaning solvent. (NOTE: The gas piston nozzle should be completely dry before reassembling the weapon. Lubrication may cause fouling when fired.)

6.5.6 Scrub the Gas Piston Cup inside and out with a dry brass wire brush. Apply a light coat of lubricant to the outside of the piston cup and wipe off any excess lubricant or residue with a rag.

NOTE: As a general practice, do not introduce any lubricant into the inside of the piston cup as this may cause fouling when fired

6.5.7 If the weapon is to be stored for a longer period of time, place a light coating of CLP on the Nozzle and reassemble. The user can wipe off the excess prior to firing. It is inconsequential to function if the user does not wipe off excess CLP prior to firing, but it may cause some smoke as the lubricant burns off with an aggressive firing schedule.

6.5.8 Scrub the Operating Rod Assembly with a GP brush dipped in cleaning solvent or CLP (these will be very clean to start with as they are not directly exposed to carbon). Thoroughly wipe away any remaining cleaning solvent or CLP with a rag. Apply a light coat of lubricant to the Operating Rod Assembly.

6.5.9 Reassemble weapon and perform functions check as detailed in Sections 3.4 and 3.5.

6.6 MAINTENANCE PROCEDURES FOR ADVERSE CLIMATE CONDITIONS

6.6.1 When operating in adverse environments LWRC International recommends utilizing shoot through muzzle covers and gun covers (tactical situation permitting).

6.6.2 Pay particular attention that the Ejection Port Cover is closed at all times when not firing your weapon. If weapons must be grounded stuff a rag into the Magazine Well.

6.6.3 In blowing sand or snow conditions conduct frequent functions checks of your weapon and take every opportunity to remove sand or snow from your weapon. A small paint brush is highly recommended for this task. Blow sand from weapon with compressed air if available.

6.6.4 Do not lubricate the interior of the Upper Receiver or exterior of the Gas Piston components when operating under field conditions in extremely sandy or snowy environments.

6.6.5 When performing routine maintenance remove the Top Rail and brush any sand or snow from the piston components.

6.6.6 Apply point lubrication as sparingly as possible.

6.7 SPECIAL ARCTIC ENVIRONMENT CONSIDERATIONS

6.7.1 Keep weapons at ambient outdoor temperature whenever possible and use an arctic rated lubricant.

6.7.2 If weapons must be brought into a warm area, allow weapons to warm up to the room temperature, detail disassemble and perform Detailed Maintenance. Pay particular attention to removing all condensation from weapon before going back into cold temperatures.

6.7.3 Even if weapons are kept outdoors, temperatures can fluctuate above and below freezing causing condensation and freezing in the weapon's moving components. Perform frequent functions checks to ensure weapon is operable.

6.7.4 If weapon is dropped in the snow clean it immediately. At a minimum break the weapon down shotgun style and remove any snow from the upper receiver and bolt carrier. Clean snow from gas piston components. Ensure bore is clear.

6.7.5 If your weapon does freeze shut DO NOT FIRE IT to un-jam the weapon. Warm weapon with body heat or a camp stove (hold weapon at least eight inches above flame and remove magazine prior to warming) until un-jammed then clean or fire immediately. Keep muzzle pointed in a safe direction.

6.8 LUBRICANTS AND CLEANERS

The R.E.P.R. is compatible with all standard U.S. Military and NATO specified small arms lubricants and cleaners. The manufacturer recommends SLIP 2000 EWL (Extreme Weapons Lubricant for 1.0 oz tube). If changing from one lubricant to another clean off old lubricant by scrubbing parts with solvent, e.g. Simple Green or SLIP 2000 Carbon Killer.

Lubrication Terms:

Light Coat- A light coat of lubricant is not readily visible to the eye. Apply lubricant and wipe off excess with a clean cloth.

Moderate Coat- A moderate coat of lubricant should be just visible to the eye. Apply lubricant directly to part and spread or apply with a brush, cloth or finger.

Point Lubrication- Lubrication applied to pivot points or recessed parts. Apply a couple of drops to the pivot point and work part back and forth to distribute lubricant.

6.9 RAIL MAINTENANCE AND NOTES

The R.E.P.R. features a free floated user configurable rail system. The rail does not come into contact with any part of the barrel allowing the use of accessories, a bipod or the rail itself as a support surface without affecting the point of impact of the bullet. The rail has a monolithic profile 12 o'clock rail that perfectly mates to the rail on the upper receiver allowing the stacking of sighting devices. The 3, 6, and 9 o'clock rail sections are user configurable. You can install one of several available rail sections to any portion of the rail tube dependant on where you usually mount your accessories. This was done to cut the weight of the rifle, and make the user interface with the system more comfortable.

6.9.1 There is no required rail maintenance other than protecting the M1913 Picatinny rail sections that remain exposed to damage with a rail or ladder panel. The R.E.P.R. rails can be set up for use with LWRCI Rail Skinz or USGI issue rail panels. Any Picatinny 1913 standard rail panel will work.

6.9.2 There are several configurations of rails and sling adapter rail sections available. Please see the LWRCI Web-Store to order additional rail sections, lengths and configurations. To install a rail section, use the supplied Allen head machine screws (they have pre-applied thread-locker already applied and are not standard machine screws). Match the installation holes on the rail section to the appropriate holes in the rail system. Install the screws using a 5/64" Allen wrench to no more than 15 inch/lbs. If you remove the Allen head screw to reposition a rail section, ensure you degrease the screw and the hole with a suitable degreasing solution (e.g. alcohol, acetone etc.). Apply blue Lock-Tite or suitable medium-strength thread locker to the screw before installation.

6.9.3 The barrel nut of the R.E.P.R. also acts as the rail mount. It is not recommended you remove the rail of the R.E.P.R. as there is no requirement to do so at the operator level.

6.9.4 There are small C-Clips that make the pusher screw captive. In the rare event this becomes dislodged or lost, a standard C-Clip for an M16 ejection port rod can be used. With the top rail removed, screw in the pusher screw all the way. With needle nose pliers, install the C-Clip to the groove toward the nose of the pusher screw.

6.9.5 During normal use, the rail will become fouled with carbon and some copper residue from jacketed ammunition. If left, the copper will turn a blue/green color. This is purely cosmetic and will not adversely affect the weapon. You can remove it with a copper solvent. You should always inspect the inside of the top rail to ensure the fouling does not interfere with piston operation. Some wear on the inside of the Top Rail is normal.

7.0 TROUBLE SHOOTING

NOTE: When shooting with a silencer or suppressor please note the following:

- 7.1** Follow Manufacturer's instructions for mounting/dismounting suppressor, for care and use.
- 7.2** Use suppressor design with same caliber of weapon.
- 7.3** Ensure suppressor is firmly attached prior to use.
- 7.4** Cyclic Rate will be increased.
- 7.5** Gas/fouling will be increased.
- 7.6** Weapon shall require an increase in lubrication and cleaning.
- 7.7** If running a suppressor for an extended period, or if the situation permits, turn the Gas Regulator to the Suppressed (S) setting.

Failure to Load	
CAUSE	CORRECTION
Bent/damage magazine feed lips or Worn/Weak magazine feed spring	Inspect Magazine and replace as necessary
Worn out/under powered recoil spring	Replace spring. Do not try to stretch.
Under powered ammunition (Cause- Short Stroke)	Use SAAMI, CIP or NATO Spec. Ammunition

Leading of feed ramps from use of Non-FMJ (Full Metal Jacket) ammunition	Disassemble and clean feed ramps and use jacketed ammunition
Failure to Lock	
CAUSE	CORRECTION
Wrong ammunition for chamber	Use proper SAAMI/CIP/ NATO Spec. Ammunition.
FOD (Foreign Object Detected) in chamber or barrel extension	Disassemble and clean rifle.
Ammunition defective/damaged or out of specification	Inspect all ammunition prior to use and ensure SAAMI/CIP/NATO compliant.
Weak/worn Buffer/Action Spring	Replace spring.

Failure to Fire	
CAUSE	CORRECTION
Defective ammunition/dead primer	Inspect all ammunition prior to use and ensure SAMI/NATO compliant.
Broken/weaken hammer spring	Replace spring.
FOD (Foreign Object Detected) in Pin Channel (Fire Control Group)	Disassemble and clean.
Worn Firing Pin	Replace firing pin
Carrier Bounce/Bolt Bounce	Adjust Gas Regulator to smaller setting. Use lower pressure ammunition.
Foreign Objects & Debris (FOD) in Fire Control Group (FCG)	Disassemble and clean.

Failure to Extract	
CAUSE	CORRECTION
Worn/Broken extractor/spring	Replace extractor/springs.
Corroded/Out of specification ammunition	Inspect all ammunition prior to use and ensure SAAMI/CIP/NATO compliant.
Worn or damaged piston return spring	Replace Piston Return Spring.
Torn case rim	Defective ammunition or dirty chamber – clean chamber and inspect ammunition.
FOD / Dirty Bolt/Extractor	Disassemble and clean.

Failure to Eject	
CAUSE	CORRECTION
Worn ejector spring	Replace spring
Short stroke	Inspect all ammunition prior to use and ensure SAMI/CIP/NATO compliant.
Regulator set on wrong setting.	Adjust Regulator to appropriate setting.

Failure to Cock	
CAUSE	CORRECTION
Worn disconnecter &/or spring	Replace disconnecter or spring.
Worn Hammer &/or Spring	Replace Hammer &/or Spring.
Worn Trigger &/or Spring	Replace Trigger &/or Spring.

WARRANTY

LWRCI™ products are warranted to be free from defective materials and workmanship for life of the original purchaser. LWRCI™ obligation under this warranty shall be limited to (1) repairing or (2) replacing any product upon inspection at LWRCI™ and based on its discretion, is found to defective in material or in workmanship. This warranty is limited and does not extend to: careless handling, abuse and misuse, unauthorized adjustments or modifications, use of improper ammunition, excessive or unreasonable use, ordinary wear & tear, rust or corrosion, and barrel obstruction. Repairs are warranted for the duration of the original warranty and applies only to factory built products

EXCLUSIVE REMEDY

The remedies in this section and in the warranty agreement constitute the sole and exclusive remedies of any authorized customer, as well as its successors and assigns, for any defect in the product.

DISCLAIMER

The warranty stated in this agreement is the sole and exclusive warranty pertaining to the product. LWRCI™ disclaims any warranty express or implied, including, without limitation, any warranty of merchantability or fitness for a particular purpose. In no event shall LWRCI™, LLC be responsible for any indirect, incidental or consequential damages including, without limitations, lost profits, costs of delay, with respect to economic loss or injury to property or to third parties, whether as a result of breach of express or implied warranty, negligence or otherwise.

Prior to returning any LWRCI™ product for warranty work, you must receive return material authorization (RMA) from our customer service department. The contact information is shown below. Items must be returned prepaid to the address shown below. LWRCI™, LLC accepts no responsibility for items lost or damaged in shipping. Items that are returned and found to be out of warranty will be repaired at the customer's expense; however, no work will be performed without the customer's written authorization.

EXPORT CONTROL

User acknowledges that any technical data furnished by LWRCI™ in connection with this order may be subject to U.S. export control laws, including but not limited to the Arms Export Control Act, 22 USC § 2778, (AECA) and the International Traffic in Arms Regulations, 22 CFR 120-130, (ITAR) promulgated pursuant thereto. In this regard, User agrees that, unless it has obtained prior written consent from the U.S. Department of State, Directorate of Defense Trade Control (DDTC), they will not export, reexport, or transship, directly or indirectly, the goods, documentation, technical assistance, or any media in which any of the foregoing is contained, or other technology provided hereunder or the direct product thereof, to any country or to any non-U.S. citizen.

CONTACT INFORMATION

Monday thru Friday: 8am thru 5pm EST
Customer Service Department
LWRC International™, LLC
815 Chesapeake Drive
Cambridge, MD 21613
410-901-1348 Fax 410-228-1775
Email: customerservice@lwrci.com

All NFA and GCA rules and laws apply to any purchase of LWRCI firearms. Please check local, state, and federal laws.

R.E.P.R. PATENTS PENDING

No part of this document may be copied, reproduced or transmitted by any means, for any purpose without prior written permission from
LWRC International, LLC.

All images and text © 2009,2010 LWRCI



LWRC INTERNATIONAL

LWRC INTERNATIONAL, LLC
815 CHESAPEAKE DRIVE
CAMBRIDGE, MD 21613
410.901.1348
410.228.1775 FAX
WWW.LWRCI.COM

015-0002

01/04/11

Rev. B