



UTAS[®]

XTR-12

www.utas-usa.com

XTR-12

UTAS-USA

XTR-12 SEMI-AUTO SHOTGUN

OPERATOR'S MANUAL

READ THIS MANUAL FIRST!

It's Important!

UTAS-USA
1247 RAND ROAD
Des Plaines, IL 60016
info@utas-usa.com
[\(847\) 768-1011](tel:8477681011)

www.utas-usa.com

STUDY THIS MANUAL CAREFULLY!

This manual provides instructions for the safe operation and maintenance of the XTR-12 shotgun. Read the manual carefully and completely understand it before you try to use your shotgun.

Your safety depends on you understanding the proper operation of your shotgun and on your knowledge of firearm's safe handling rules. Study the section on common-sense safety rules in this manual. Firearms safety is your responsibility!

Another responsibility as a gun owner is security. Make sure that your shotgun remains in responsible hands at all times and make sure your shotgun is properly secured when not in use. Store your shotgun in a locked gun safe or secure storage container well away from children when not in use.

The following section of this manual lists firearms safety rules, including how to clear your shotgun and render it safe. The next section explains operation of the XTR 12 shotgun, followed by instruction on proper maintenance. The final section covers trouble-shooting problems.

NOTICE OF CLAIMS

UTAS-USA shall not be responsible for injury, death, or damage to property resulting from the intentional or accidental discharge of this firearm, or when used for purposes for which it was not intended. UTAS-USA will not honor claims under the Limited Warranty which result from careless or improper handling, unauthorized adjustments, parts replacement, corrosion, neglect, use of the wrong ammunition, or the use of ammunition other than original, high quality commercially manufactured ammunition, or any event brought on by negligence or ignorance of proper use.

UTAS-USA will only honor warranty claims made by the **original owner**.

Contact UTAS-USA directly at +1-847-768-1011 with any questions, or to arrange to return a shotgun for service.

SAFETY IS YOUR RESPONSIBILITY!

- Always keep the muzzle pointed in a safe direction.
- Never point your shotgun at anything that you do not intend to shoot.
- Keep your fingers off the trigger and out of the trigger guard until you are aiming at your target and ready to shoot.
- Always keep the safety on the safe position, until you are ready to fire.
- Always keep and carry your shotgun with an empty chamber until you intend to shoot, so that your shotgun cannot be fired unintentionally. Firearms should be unloaded when not actually in use...
- ***But treat every gun as if it is loaded... AT ALL TIMES.***
- Be sure of your target and backstop before you shoot. Ask yourself what your shot will hit if it misses or goes through the target.
- Never shoot at hard, flat surfaces or water... pellets can ricochet.
- Wear safety glasses and hearing protection when shooting.
- Discharging firearms in poorly ventilated areas, cleaning firearms, or handling ammunition may result in exposure to lead, a substance known to be associated with birth defects, reproductive harm, and other serious injury.
Have adequate ventilation at all times and wash hands after handling.
- Be sure that your barrel is clear of obstructions, including excessive oil and grease, before shooting.
- Do not alter or modify your shotgun.
- Do not try to change your shotgun's trigger pull, because alterations of trigger pull usually affect sear engagement and might cause accidental firing.
- Store guns and ammunition separately, and beyond children's reach.

IF YOUR SHOTGUN SHOULD MALFUNCTION REVIEW THIS MANUAL TO IDENTIFY AND RESOLVE THE PROBLEM. IF YOU CANNOT RESOLVE THE PROBLEM, CONTACT UTAS-USA IMMEDIATELY

KEEP THIS MANUAL WITH YOUR SHOTGUN. IF YOU SELL THE SHOTGUN, GIVE THIS MANUAL TO THE NEW OWNER.

TABLE OF CONTENTS

Instruction and Claims	3
Firearms Safety	4
Clearing the Shotgun	6
Safety Check	8
Operating Procedures:	9
Loading	9
Chambering and Firing	10
Collapsible Buttstock	13
Field Stripping:	13
Clearing the Shotgun	13
Handguard	13
Gas System	14
Upper Housing and Lower Receiver	15
Charging Handle and Bolt Carrier Group	16

Lower Receiver Assembly	18
Maintenance, Cleaning and Inspection:	19
Upper Housing and Barrel Assembly	20
Charging Handle and Bolt Carrier Group	23
Lower Receiver Assembly	25
Reassembly	27
Lower Receiver Assembly	27
Charging Handle and Bolt Carrier Group	27
Gas System Assembly	29
Upper Housing and Lower Receiver	30
Handguard	30
Trouble Shooting	31
XTR-12 Parts List	33
Warranty and Service	35

CLEARING YOUR SHOTGUN:

Keep your shotgun cleared when not in use.

**1. Place safety lever (1) on SAFE.**

NOTE: If the shotgun is not cocked, the lever cannot be pointed toward SAFE.



2. Remove the magazine (2) by depressing the magazine catch button (3) and pulling the magazine down.

**3. Extract the cartridge (if any) from the chamber.**

To lock the bolt open, pull the charging handle (4) rearward, press the bottom of the bolt catch (5), and allow the bolt to move forward until the bolt catch stops it. Return the charging handle forward.

4. Look in to the receiver and chamber (6) to ensure that these areas contain no ammunition.



CAUTION!

DO NOT REVERSE THE STEPS IN CLEARING YOUR SHOTGUN. IF YOU CLEAR THE CHAMBER BEFORE REMOVING THE MAGAZINE, YOU MAY REMOVE ONE SHELL THEN IMMEDIATELY CHAMBER ANOTHER FROM THE MAGAZINE! THE SHOTGUN WILL BE STILL LOADED!

SAFETY CHECK**WARNING**

Make sure that the magazine is removed and the chamber is clear.

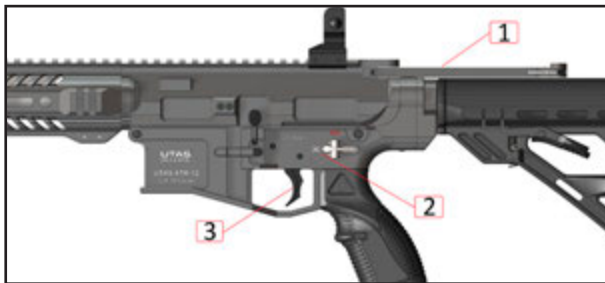

1. Pull the charging handle (1) to the rear and release it. Place the safety (2) on SAFE. Squeeze the trigger (3). The trigger should not fall.

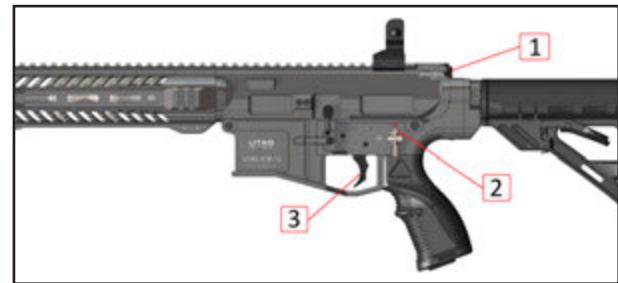

2. Place the safety (2) on FIRE. Squeeze the trigger (3) and hold the trigger to the rear; the hammer should fall. Pull the charging handle (1) to the rear and release it. Release the trigger. You should hear a click as you release the trigger. Squeeze again; the hammer should fall.

Call UTAS-USA at +1-847-768-1011 if your shotgun fails either test.

OPERATING PROCEDURES

LOADING THE 12 Ga. XTR-12® MAGAZINE

Insert the first round. To load the second round, press the plunger at the rear of the follower into its hole as you insert the round. Insert the remaining rounds just as you did the first one.

Take it easy with your magazines. Keep them clean, dry, and don't pound them into the shotgun. Insert them smoothly then check to assure they're locked in the shotgun by tugging downward.

WARNING! Always point the muzzle in a safe direction.



1. Pull the charging handle (1) rearward, lock the bolt, and release the charging handle. Place the safety (2) on SAFE. Check to see that the chamber is clear and the bore is not blocked.



2. Push upward on the magazine (3) until the magazine catch (4) engages and holds the magazine. Pull down on the magazines lightly to make sure that it is locked in place.

XTR-12 MAGAZINE: The shells in a fully loaded magazine can be packed tight. If loading the magazine or inserting it into the shotgun is hard or if shotgun operation is sluggish, load the magazine with 1 less round or insert the magazine into the shotgun with the bolt open.

CHAMBERING AND FIRING A ROUND, STARTING WITH THE BOLT OPEN



1. Depress the upper portion of the bolt catch (1) to release the bolt.



2. With the shotgun pointed in a safe direction, move the safety (3) to FIRE.



3. Squeeze the trigger (4) and fire.

CHAMBERING AND FIRING A ROUND, STARTING WITH THE BOLT CLOSED



1. Insert magazine (3) until magazine catch (4) engages. Pull down slightly to assure proper seating. NEVER tap or pound the magazine into the receiver.



2. Pull the charging handle (2) all the way back.



3. Release the charging handle (2). If the bolt carrier doesn't fully close, clear the shotgun and correct the problem.

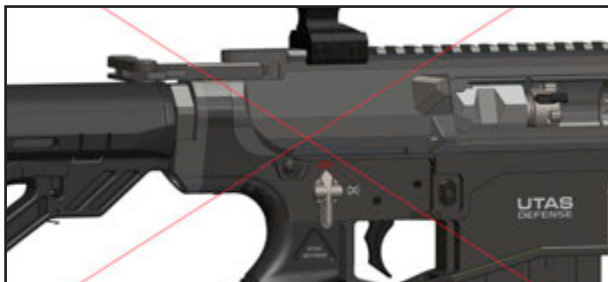

4. Never “ride” the charging handle. Let it slide forward at full speed.

Keep the safety on SAFE until you are ready to shoot. Unload and clear your shotgun before leaving the firing position.

CAUTION!

DO NOT REVERSE THE STEPS IN CLEARING YOUR SHOTGUN. IF YOU CLEAR THE CHAMBER BEFORE REMOVING THE MAGAZINE, YOU MAY REMOVE ONE SHELL THEN IMMEDIATELY CHAMBER ANOTHER FROM THE MAGAZINE! THE SHOTGUN WILL BE STILL LOADED!

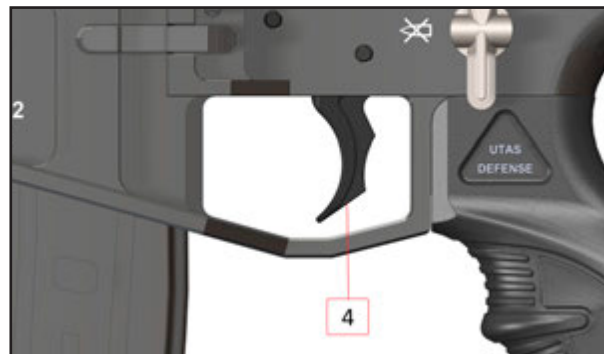

5. Set the safety to FIRE, grip the shotgun firmly, and squeeze the trigger (4). Note: Gripping the shotgun loosely when firing can cause the shooter to fire two shots (the second as the trigger strikes the shooter's trigger finger during counter-recoil.) This is a shooter error, not a shotgun malfunction.

ADJUSTING THE COLLAPSIBLE BUTT STOCK

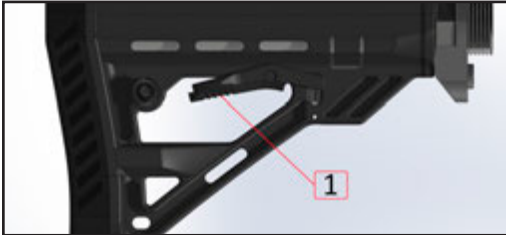

To extend the collapsible buttstock, depress lever (1) and pull the stock out until it locks into position.



To collapse the buttstock depress the lever (1) again and push forward until it locks into position.

MAINTENANCE PROCEDURES: FIELD STRIPPING

CLEAR THE SHOTGUN



IMPORTANT: Put the safety on SAFE. Remove the magazine, THEN pull back the charging handle (1) and check the chamber.



HAND GUARD

1. Loosen the flash suppressor nut (2), then remove the flash suppressor (1),



2. Loosen the hand cover ring screws and then remove the hand cover ring.



3. After that loosen the handguard Screws (3)

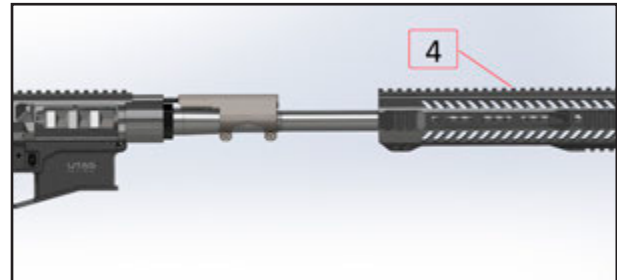

4. Pull the handguard (4) free.

GAS SYSTEM

Remove gas cylinder valve (1) with hex key
 Push gas piston rod (3) until gas piston (2) drops out
 Remove gas piston rod (3)

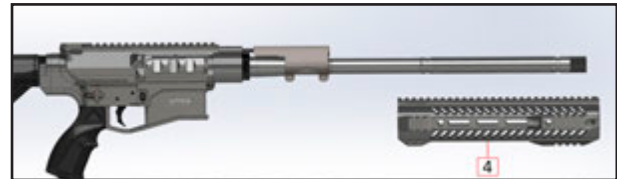

UPPER HOUSING AND LOWER RECEIVERS

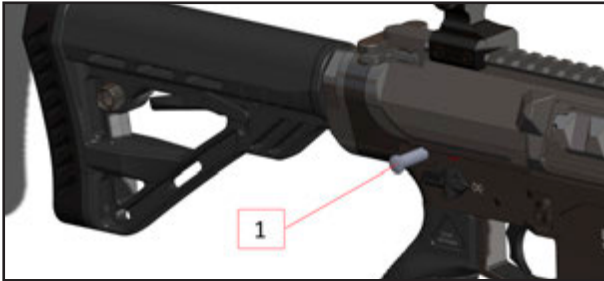

1. Push the takedown pin (1) as far as it will go.
Caution: Excess force can severely damage the receiver.

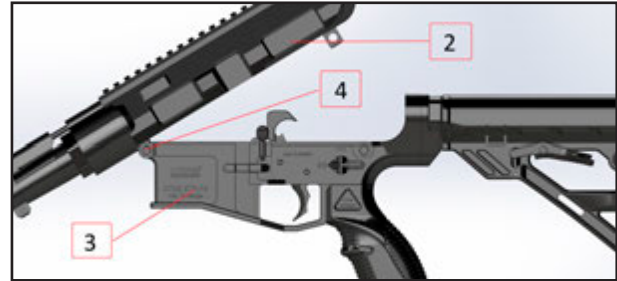

2. Pivot the upper housing (2) from the lower receiver (3).

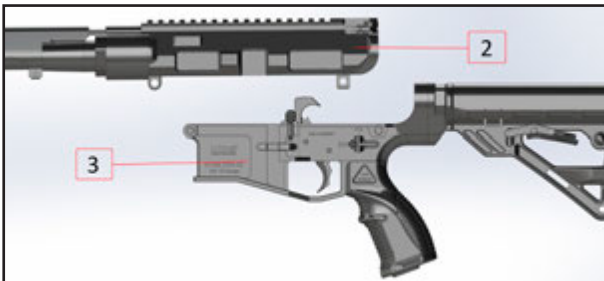

3. Push the receiver pivot pin (4) as far as it will go.

Note:

Pivot and Takedown pins are not removed completely from the lower receiver and should only be pushed far enough to remove the upper housing.

Caution:

Excess force could destroy or damage the receiver!
 Separate the upper housing and lower receiver.

CHARGING HANDLE AND BOLT CARRIER ASSEMBLY



1. Pull back the charging handle (1) and bolt carrier assembly (2).



2. Remove the bolt carrier assembly (2).



3. Pull the charging handle (1) back and down to remove it.

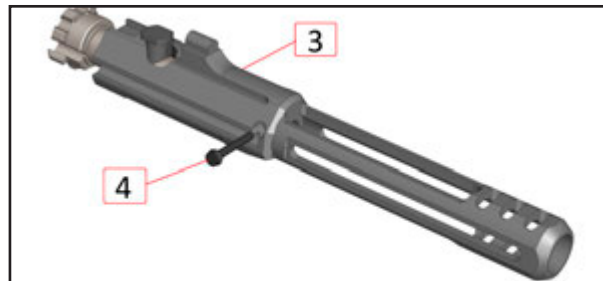

4. Move the bolt assembly (3) forward to the unlocked position and remove the firing pin retaining pin (4).

5. Push in on the bolt assembly (3) to put it in the locked position

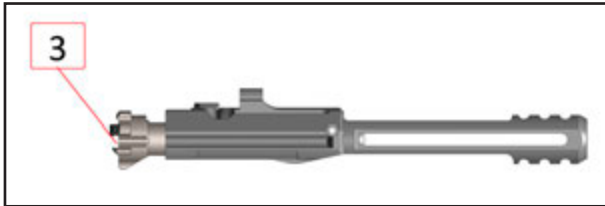

6. Catch the firing pin (5) as it drops out of the rear of the bolt carrier assembly.



7. Lift the bolt cam pin (6) out from the bolt body.

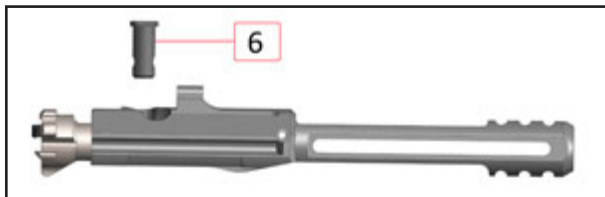

8. Remove the bolt head (7) from the bolt carrier assembly

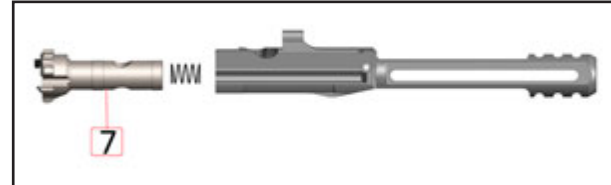

9. Press the rear of the extractor (8) to check that the spring works.

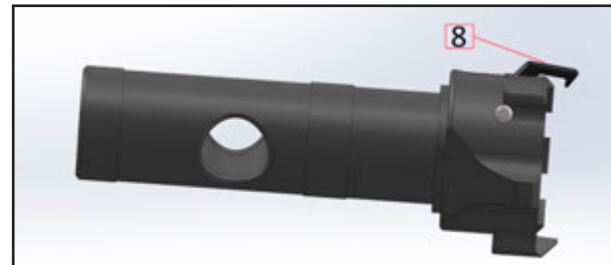

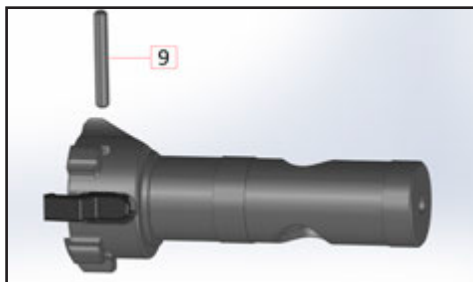

10. Use a drift punch to remove the extractor pin (9).

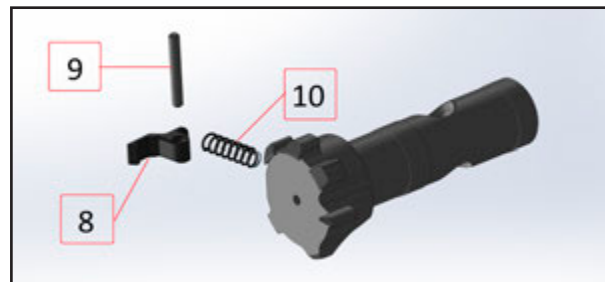

11. Remove the extractor (8), pin (9), and spring (10).

LOWER RECEIVER ASSEMBLY



1. Cock the hammer with your thumb. Push in the buffer (1) and depress the retainer (2) to release the buffer.

Note: Accidentally dropping the hammer can cause damage to the receiver.

NO FURTHER DISASSEMBLY IS REQUIRED

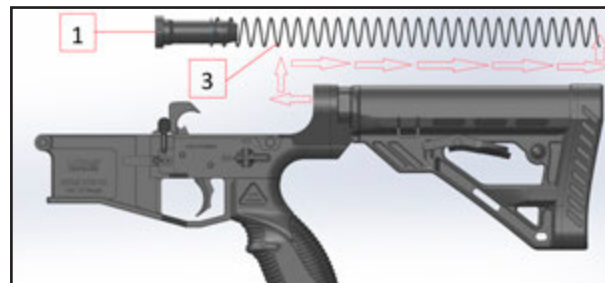

2. Remove the buffer (1) and the buffer spring (3).

MAINTENANCE PROCEDURES: CLEANING

USE QUALITY CLEANING SOLVENTS AND LUBRICANTS ONLY

In addition to cleaning solvents and lubricants, the basic cleaning equipment you will need includes a cleaning rod, brass bore brush, chamber brush, toothbrush, patches, pipe cleaners, and the most important item: a lint-free cloth. UTAS-USA recommends a pull-through cleaning cable for efficient, breech-to-muzzle cleaning.

UPPER HOUSING AND BARREL ASSEMBLY NOTE



1. Don't reverse the direction of the bore brush while it's in the bore.

2. Use cleaning solvent on the bore and chamber, the gas system, the upper housing and barrel assembly, locking lugs and all areas of powder fouling, corrosion, dirt or dust.



3. Use a cleaning rod, bore brush and cleaning solvent. Run the rod through the chamber (1) and flash suppressor (if applicable) several times. The recoil check (if present) (2) is not removable.

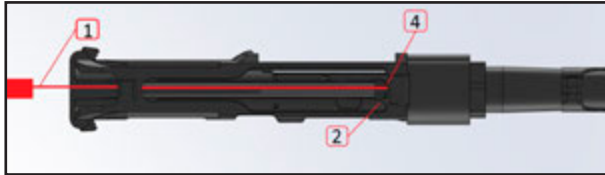

4. Install the chamber brush on the cleaning rod (1), dip it in cleaning solvent, and insert it into the chamber (2) and locking lugs (4). Clean by pushing and twisting the cleaning rod.

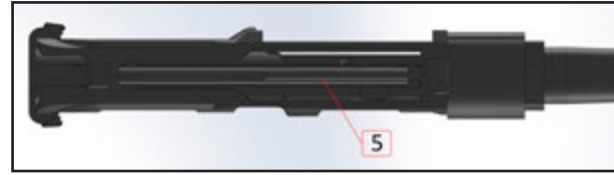

5. Use a worn out bore brush to clean the outside surface of the protruding gas piston rod (5) (get the sides and bottom from the bottom of the upper housing). This procedure ruins the brush.



6. Take the bore brush off the rod (1) and install a swab holder and a swab. Apply cleaning solvent to the swab, then run it through the chamber (2) and out the flash suppressor (if applicable) (3). To remove carbon build up, let the solvent sit, then wipe clean. A bore brush may be used with care to remove heavy carbon buildup. Wipe the bore dry by running clean swabs all the way through from the chamber to the flash suppressor. **REMEMBER;** do not change directions in the bore.

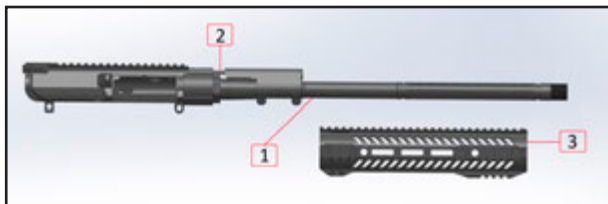

7. Inspect the barrel (1), gas piston (2), and hand guards (3) for cracks, bends, or breaks. Be sure the barrel has no obstructions.

8. Lightly lubricate the bore and chamber, outer surface of the barrel and front sight, and the surfaces under the handguard.

9. With a lubricated swab, run the rod from the receiver to the flash suppressor (if applicable). Do not over lubricate.

10. Lubricate the locking lugs.



Clean and dry gas piston (2), gas piston rod (3), gas cylinder valve (1) and interior of gas cylinder.

CHARGING HANDLE AND BOLT CARRIER ASSEMBLY

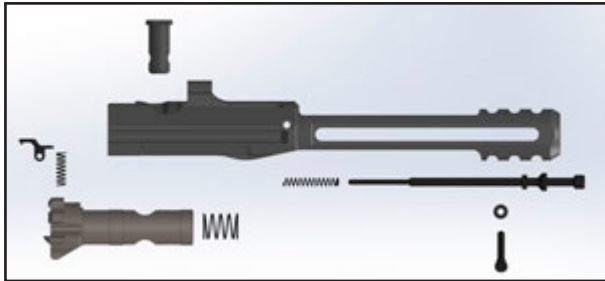

1. Clean all parts and outer surfaces of the bolt carrier assembly with a swab saturated with cleaning solvent.

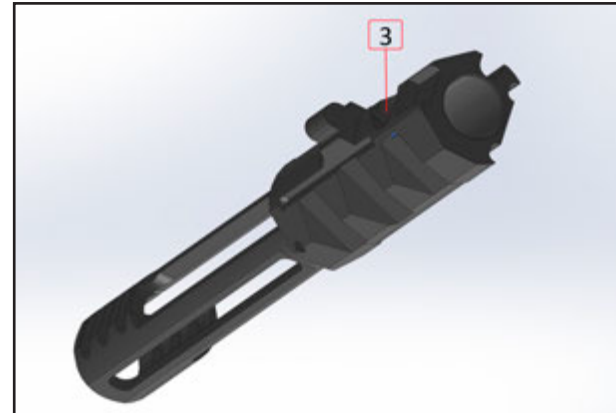

2. Remove carbon deposits and dirt from the locking lugs (3) with a bore brush dipped in solvent and remove excess solvent with a dry cleaning patch.

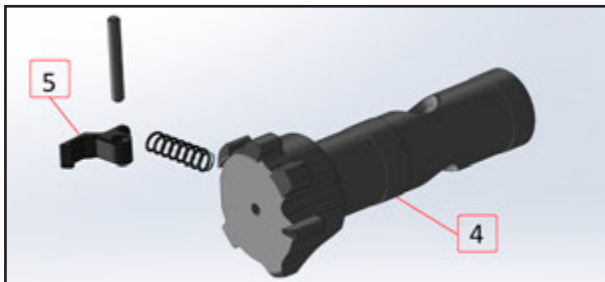

3. Clean the lugs and face of the bolt head (4) and under the lip of the extractor (5). Press the extractor in repeatedly to remove accumulated brass shavings from the extractor hole and assure the extractor moves freely. Lubricate it generously.

1. Clean the firing pin (1) and in the bolt assembly.

2. Generously lubricate the outside of the bolt cam pin (3) and the firing pin retaining pin (4). Make certain to lubricate the bolt cam pin hole (5), bolt head spring (6), and firing pin spring (7).

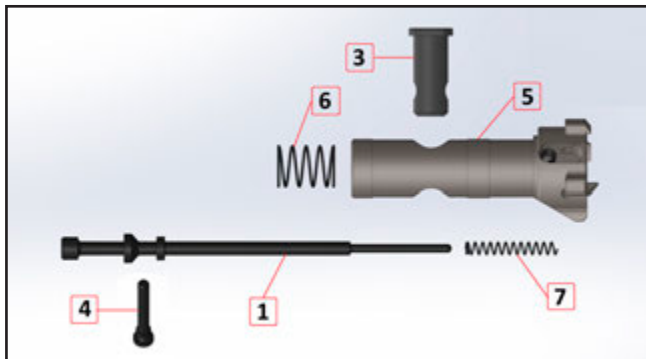

3. Clean the inner and outer surfaces of the bolt carrier.

4. Lightly lubricate the slide (9) and the cam pin area (10) of the bolt carrier.

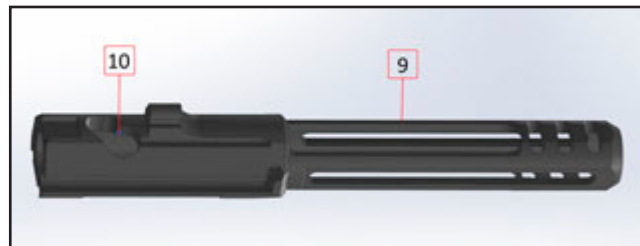

5. Clean the charging handle (11).

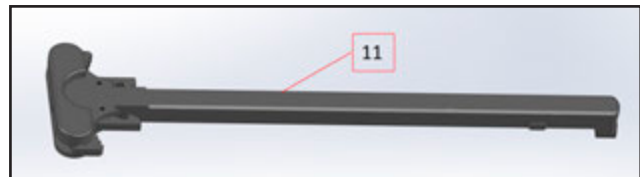

LOWER RECEIVER ASSEMBLY

CAUTION

Do not use a wire brush or any type of abrasive material to clean aluminum surfaces

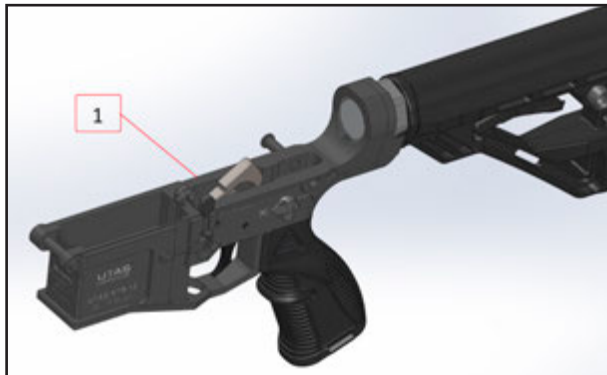

1. Wipe dirt from the trigger with a swab.
2. Use a swab and cleaning brush to clean powder fowling, corrosion, and dirt from the lower receiver, (1).

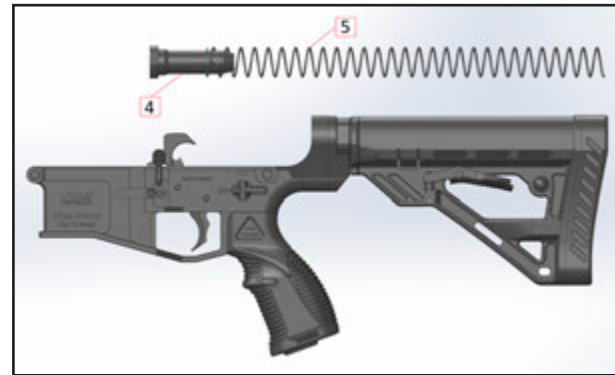

3. Clean the buffer (4), recoil spring (5), and inside lower receiver with a swab dipped in solvent.

MAINTENANCE PROCEDURES: CLEANING AND INSPECTION LOWER RECEIVER ASSEMBLY (CONTINUED)

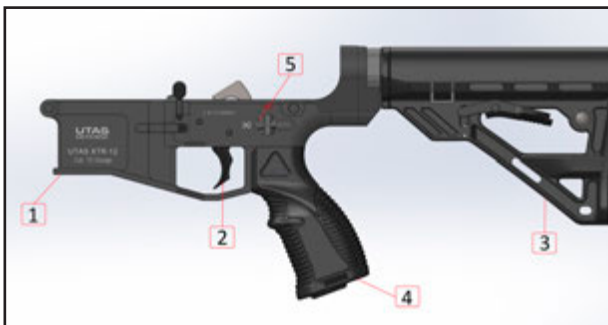

1. Examine the lower receiver assembly for a broken or bent trigger (2) butt stock (3), corroded or deformed lower receiver (1), cracked or damaged grip (4), and bent or damaged safety (5). Look at the inside parts for cracks, dents, or breaks.

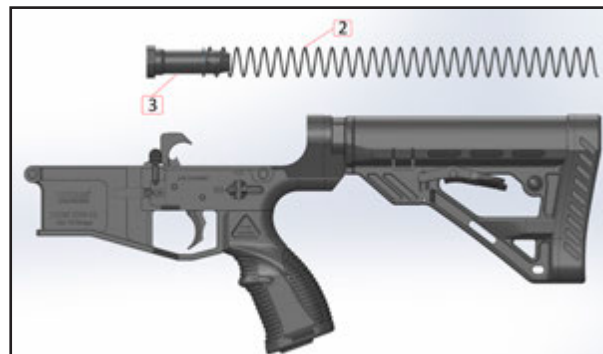

2. Lightly lubricate the recoil spring (2) and buffer (3).

REASSEMBLY LOWER RECEIVER AND BUTTSTOCK ASSEMBLY

1. Depress the retainer (2) and insert buffer spring (1) and buffer.

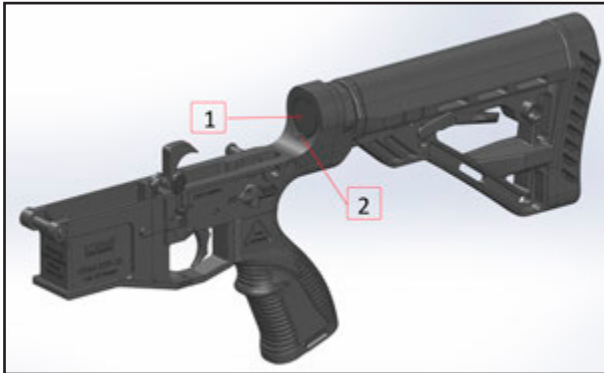

CHARGING HANDLE AND BOLT CARRIER

NOTE

The extractor has a silicone insert in the spring(2). Don't lose it.

1. If the spring comes loose, seat the large end of the spring in the extractor. Assure the reinforcement ring is around the spring.
2. Insert the extractor (3) with extractor spring (2), into bolt head (1).

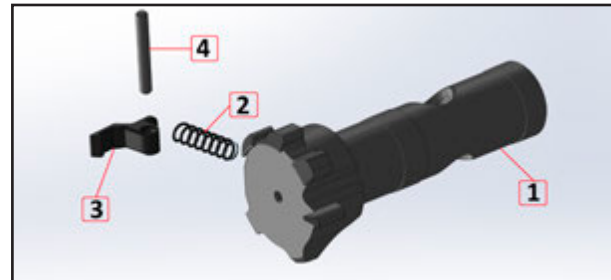

3. Push extractor until the holes on the extractor (3) and bolt are aligned and insert the extractor pin (4).

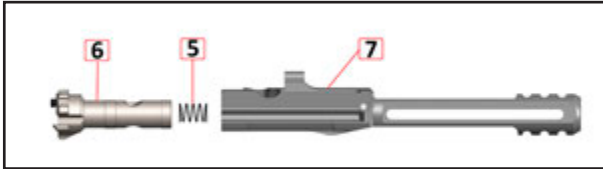

4. Slide the bolt assembly (6) and bolt spring (5) into the bolt carrier (7) **only far enough to insert the cam pin.**



5. Insert the bolt cam pin (8) and give it a ¼ turn so the hole is aligned for the firing pin

6. Drop the firing pin (9) into its opening. (verify that the tight end of the firing pin spring engages the groove on the firing pin.)

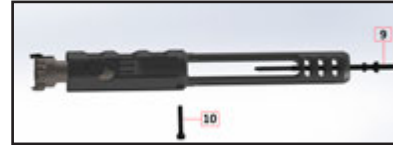

7. Pull the bolt assembly forward and insert the firing pin retaining pin (10) in the area behind the large flange of the firing pin (9). (Push the firing pin to verify the spring returns.)



8. Turn the bolt carrier assembly up and try to shake out the firing pin. The firing pin must not fall out.



9. Place the charging handle into the upper housing and engage the handle's lugs with the track in the housing, then push the charging handle (11) part way into the upper housing.



10. Slide the bolt carrier assembly (7), bolt extended, into the upper housing.

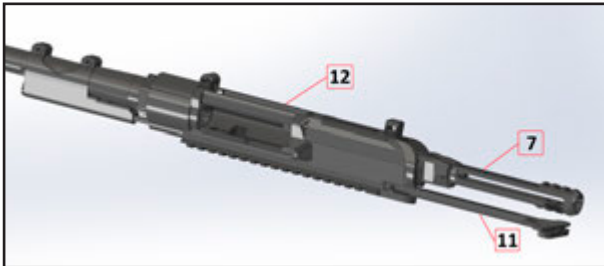

11. Push the charging handle assembly (11) and bolt carrier assembly (7) together into the upper housing (12).



GAS SYSTEM ASSEMBLY

1. Drop gas system rod (1) into gas cylinder (4)
2. Place gas piston (2) (cup side down) into gas cylinder (4)

CAUTION: Make sure gas piston (2) moves freely inside gas cylinder (4)

3. Screw gas cylinder valve (3) into gas cylinder (4) until tight

UPPER HOUSING AND LOWER RECEIVER

NOTE

The hammer must be in cocked position to join upper housing and lower receiver.

1. Join the upper housing and lower receiver.



2. Align the pivot pin holes with the pivot pin and push the pivot pin (3) in.

CAUTION

3. Close the ejection port cover before the upper housing and lower receiver are joined to prevent damage to the cover.



4. Close the upper housing and lower receiver. Push in the takedown pin (4).

HANDGUARD



1. Slide the hand guard over the barrel and gas piston assembly fully rearward, replace the two attachment screws on the bottom and tighten.

Caution: Do not over tighten

TROUBLESHOOTING THE XTR-12 SHOTGUN

PROBLEM	CHECK FOR	WHAT TO DO
WON'T FIRE	Selector lever on SAFE.	Put it on FIRE.
Improper assembly of firing pin.	Assemble correctly. NOTE: The firing pin retaining pin goes in back or large shoulder of firing pin.	
Oil or fouling in bolt.	Clean	
Defective ammunition.	Remove and discard.	
Too much carbon on firing pin or firing pin recess.	Clean.	

BOLT WON'T LOCK.

Dirty bolt. Clean.
Buried or broken bolt. Contact UTAS-USA.

WON'T EXTRACT.

Broken extractor spring. Replace.
Silicone insert or reinforcement ring missing from extractor spring. Replace.
Dirty, corroded, or reloaded ammunition. Remove and discard.
Carbon in chamber. Clean chamber.
Frozen or worn extractor. Remove and clean.
Restricted buffer assembly. Remove and clean.
Restricted movement of bolt carrier assembly. Remove, clean and lubricate.
Fouled gas system. Clean
Short recoil. See below.

WON'T FEED.

Dirty, corroded, or reloaded ammunition. Remove and discard.
Dirty or defective magazine. Clean or replace.
Too many rounds in magazine. Remove excess rounds.
Buffer assembly is restricted. Take out and clean buffer and buffer spring.
Magazine not fully seated. Adjust magazine catch: Press button on right side, and turn catch on left.
Clockwise tightens.

DOUBLE FEED

Defective magazine. Replace.

WON'T CHAMBER

Dirty corroded or defective ammunition. Remove and discard.
Residue in chamber. Clean.

WON'T LOCK

Dirt, corrosion, or carbon build up in barrel locking lugs. Clean lugs.

SHORT RECOIL

Fouled Gas System Clean
Weak or reloaded ammunition. Replace with factory fresh ammunition,
Short recoil. See below.

BOLT FAILS TO LOCK OPEN AFTER LAST ROUND.

Dirty or corroded bolt catch. Clean or replace.
Defective magazine. Replace.

SELECTOR LEVER BINDS

Needs oil. Lubricate.
Dirt or sand under trigger. Clean.

XTR 12 PART LIST

NO.	PART NUMBER	PART NAME	QTY
1	XTR12BBL01	Barrel Blank	1
2	XTR12BBL02	Barrel Extension	1
3	XTR12BBL03	Barrel Indexing Screw	1
4	XTR12BBL04	Gas Cylinder	1
5	XTR12BBL05	Gas Cylinder Screws	2
6	XTR12BBL06	Gas Piston Rod	1
7	XTR12BBL07	Gas Piston	1
8	XTR12BBL09	Gas Cylinder Valve	1
9	XTR12BBL10	Flash Hider	1
10	XTR12BBL11	Flash Hider Nut	1
11	XTR12BBL12	Barrel Nut	1
12	XTR12BBL13	Barrel Blank	1
13	XTR12BLT01	Bolt Body	1
14	XTR12BLT02	Bolt Head	1
15	XTR12BLT03	Bolt Head Spring	1
16	XTR12BLT04	Cam Pin	1
17	XTR12BLT05	Extractor	1
18	XTR12BLT06	Extractor Pin	1
19	XTR12BLT07	Extractor Spring	1
20	XTR12BLT08	Firing Pin	1
21	XTR12BLT09	Firing Pin Retaining Pin	1
22	XTR12BLT10	Firing Pin Spring	1
23	XTR12HGD01	Handguard	1
24	XTR12HGD02	Handguard Cover	1
25	XTR12HGD03	Handguard Screws	2
26	XTR12HGD04	Gas Cylinder Screw for Handguard	2
27	XTR12HGD05	Upper Hand cover ring	1
28	XTR12HGD06	Lower Hand cover ring	1
29	XTR12HGD07	Handguard ring screw	2
30	XTR12LWR01	Lower Receiver Body	1
31	XTR12LWR02	Safety Selector Body	1
32	XTR12LWR03	Safety Selector Left Ambi	1
33	XTR12LWR04	Safety Selector Right Ambi	1

NO.	PART NUMBER	PART NAME	QTY
34	XTR12LWR05	Safety Selector Screws	2
35	XTR12LWR06	Selector Spring Detent	1
36	XTR12LWR07	Selector Spring	1
37	XTR12LWR08	Hammer	1
38	XTR12LWR09	Hammer Pins	2
39	XTR12LWR10	Hammer Spring	1
40	XTR12LWR11	Trigger	1
41	XTR12LWR12	Trigger Spring	1
42	XTR12LWR13	Disconnecter	1
43	XTR12LWR14	Disconnecter Spring	1
44	XTR12LWR15	Magazine Catch Ambi	1
45	XTR12LWR16	Magazine Catch Lock Ambi	1
46	XTR12LWR17	Magazine Catch Lock Pin Ambi	1
47	XTR12LWR18	Magazine Catch Spring	1
48	XTR12LWR19	Magazine Catch Lock Spring Ambi	1
49	XTR12LWR20	Magazine Release Button	1
50	XTR12LWR21	Bolt Catch	1
51	XTR12LWR22	Bolt Catch Plunger	1
52	XTR12LWR23	Bolt Catch Roll Screw	1
53	XTR12LWR24	Bolt Catch Spring	1
54	XTR12LWR25	Pistol Grip	1
55	XTR12LWR26	Pistol Grip Cover	1
56	XTR12LWR27	Pistol Grip Cover Lock	1
57	XTR12LWR28	Pistol Grip Cover Lock Pin	1
58	XTR12LWR29	Pistol Grip Cover Lock Spring	1
59	XTR12LWR30	Pistol Grip Screw	1
60	XTR12LWR31	Buffer Retainer	1
61	XTR12LWR32	Buffer Retainer Spring	1
62	XTR12LWR33	Pivot Pin	1
63	XTR12LWR34	Pivot Pin Springs	2
64	XTR12LWR35	Take Down Pins Detent	2
65	XTR12LWR36	Take Down Pin	1
66	XTR12LWR37	Hammer Lock Spring	1

NO.	PART NUMBER	PART NAME	QTY
67	XTR12MAG01	Magazine Body Metal 5	1
68	XTR12MAG02	Magazine Floor Plate	1
69	XTR12MAG03	Magazine Floor Plate Lock	1
70	XTR12MAG04	Magazine Follower	1
71	XTR12MAG05	Magazine Follower Spring	1
72	XTR12STK01	Stock Body	1
73	XTR12STK02	Stock Latch	1
74	XTR12STK03	Stock Lock Pin Spring	1
75	XTR12STK04	Stock Pad	1
76	XTR12STK05	Stock Pad Insert	1
77	XTR12STK06	Stock Pad Screw	2
78	XTR12STK07	Stock Pin Butt Stock Slide Lock	1
79	XTR12STK08	Stock Roll Pin Long	1
80	XTR12STK09	Stock Roll Pin Short	1
81	XTR12STK10	Stock Tube Lock	1
82	XTR12STK11	Buffer Body	1
83	XTR12STK12	Buffer Cap	1
84	XTR12STK15	Buffer Pin	1
85	XTR12STK16	Buffer Spring	1
86	XTR12STK17	Buffer Tube	1
87	XTR12STK18	Buffer Tube Nut	1
88	XTR12STK19	Sling Screw	1
89	XTR12STK20	Sling Swivel	1
90	XTR12STK21	Sling Swivel With Screw	1
91	XTR12UPR01	Upper Housing Body	1
92	XTR12UPR02	Charging Handle	1
93	XTR12UPR03	Charging Handle Latch	2
94	XTR12UPR04	Charging Handle Latch Spring	1
95	XTR12UPR05	Charging Handle Latch Pin	2
96	XTR12UPR06	Ejector	1
97	XTR12UPR07	Ejector Screws	2

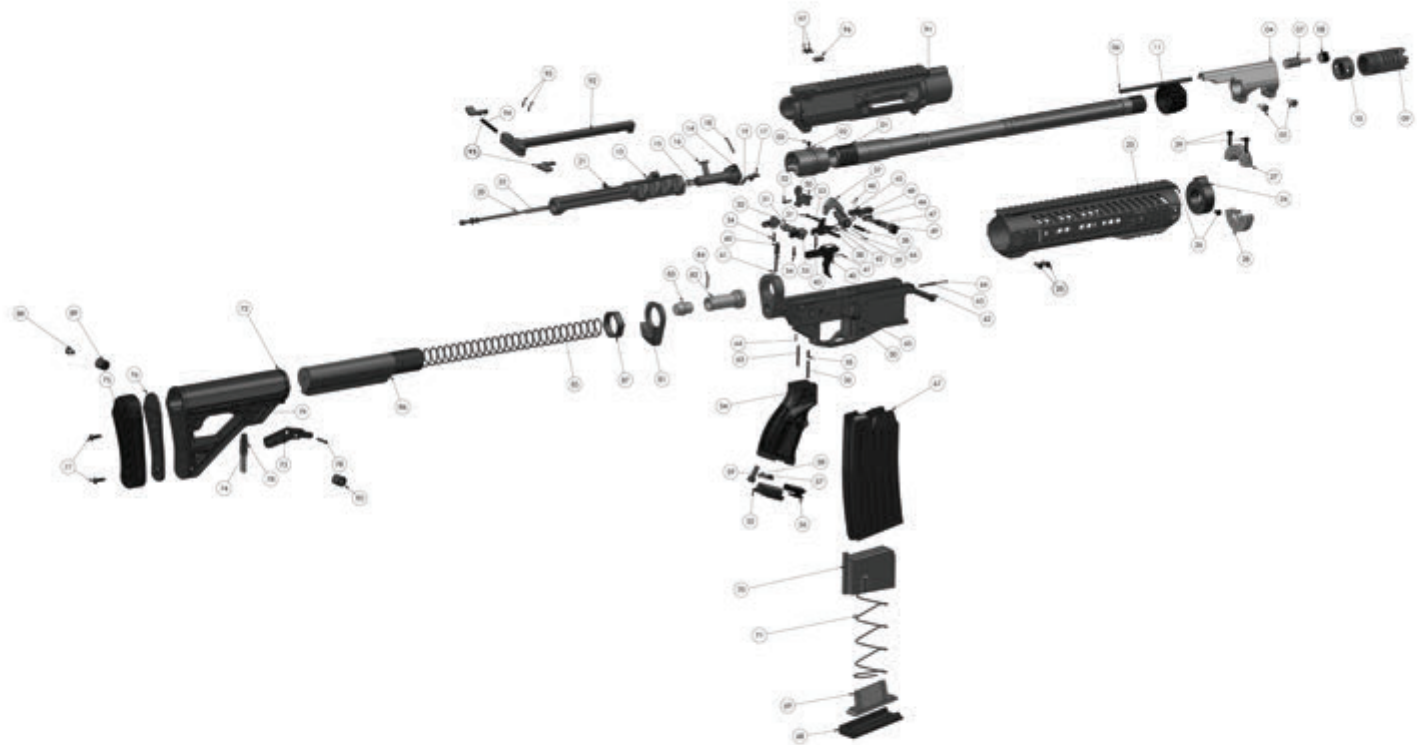

WARRANTY & SERVICE

Your XTR-12 shotgun is warranted for a period of one year from the date of purchase to be free of defects in materials and workmanship. If you are having functional difficulties, please call UTAS-USA at (847) 768-1011 and discuss it with us. To register your new shotgun and activate your warranty go on-line to www.utas-usa.com and click on warranty registration or send a copy of proof of purchase to:

UTAS-USA
1247 Rand Road
Des Plaines, IL 60016



UTAS[®]

XTR-12

UTAS-USA
1247 Rand Road, Des Plaines, IL 60016. USA
Phone : +1 847 768-1011
Fax : +1 847 768-1001
E.mail : info@utas-usa.com

www.utas-usa.com

01 NOV 2015