

# LANCER

## L15 OWNERS MANUAL



MODEL: \_\_\_\_\_

SERIAL NUMBER: \_\_\_\_\_

INDEX	PAGE
1. GENERAL HANDLING CAUTIONS.....	3
2. GENERAL WARNING.....	3
3. IMMEDIATE ACTION.....	4
4. CONTROLS / COMPONENTS.....	5
5. SAFETY SELECTOR.....	6
6. LOADING THE RIFLE .....	7
7. UNLOADING THE RIFLE.....	7
8. CLEARING THE RIFLE.....	8
9. BARREL BREAK-IN.....	8
10. ADJUSTING THE STOCK.....	9
11. CHANGING THE MAGAZINE WELL EXTENSION.....	9
12. MOUNTING SIGHT AND OPTICS.....	10
13. MAINTENANCE .....	10
13.1. FIELD STRIPPING & DISSASSEMBLY.....	10
13.2. CLEANING & INSPECTION.....	13
13.3. LUBRICATION.....	15
13.4. ASSEMBLY.....	17
14. SPECIFICATION.....	21
15. TROUBLE SHOOTING.....	22
16. WARRANTY.....	23



## **WARNING**

If this firearm is carelessly or improperly handled, unintentional discharge could result and could cause personal injury, death or damage to property.

FOR YOUR SAFETY AND THE SAFETY OF OTHERS, this Operations Manual contains important instructions, warnings and safety procedures that must be understood BEFORE using your Lancer firearm. It is imperative that you read the ENTIRE MANUAL and if you do not understand any part of it or the operation of your firearm, you should seek professional firearms instruction.

**WARNING-** Keep out or reach of children. Prevent child access by always keeping guns locked away and unloaded when not in use. If you keep a loaded firearm where a child obtains and improperly uses it, you may be fined or sent to prison.

## **NOTICE**

Lancer Systems shall not be responsible for personal injury, death or damage to property resulting from either intentional or accidental discharge of this firearm, or from its function when used for purposes or subjected to treatment for which it was not designed. Lancer Systems will not honor claims involving this firearm which result from careless or improper handling, unauthorized adjustment or parts replacement, corrosion, neglect, or the use of wrong caliber ammunition, other than original high quality commercially manufactured ammunition in good condition, or any combination thereof. Lancer Systems will not honor claims involving this firearm for any reason or cause when the second or subsequent owner makes such claims.

Before the rifle left the factory, it was tested, carefully inspected and packaged. Lancer Systems cannot control product handling after it leaves the factory; therefore please examine this firearm carefully at the time of purchase to ensure that it is unloaded and undamaged.

## 1. GENERAL HANDLING CAUTIONS

- Do not alter or modify your Lancer L15 Rifle.
- Always handle your firearm as if loaded.
- Never point your firearm at anything you don't intend to shoot.
- Always make sure your firearm is not loaded and the bolt is latched open and to the rear before laying it down or handing it to someone else.
- Never leave a loaded firearm unattended.
- Always be sure bore, muzzle, chamber and action are clear of obstruction.
- Always check that ammunition is clean and undamaged.
- Never drink alcoholic beverages or take drugs before or during shooting.
- Always wear eye and ear protection when shooting.
- Always keep safety on "SAFE" when firearm is loaded and a round is chambered until ready to shoot.
- Never attempt to fire if water is in the bore.
- Never indulge in "horseplay" when holding your firearm.
- Keep your Lancer L15 rifle clean and lubricated

## 2. GENERAL WARNING

- **ALWAYS LOAD YOUR RIFLE WITH THE BARREL POINTED DOWN RANGE AND/OR IN A SAFE DIRECTION.**
- Be sure the cam pin is installed in the bolt group. If it isn't, your rifle can still fire but it could possibly explode, causing you personal injury or harm.
- Do not exchange or switch bolt assemblies from one rifle to another. Doing so could result in injury to you and others and damages to your rifle.
- Be aware while shooting for SLAM FIRE, HANG FIRE or a SQUIB

### 2.1 SLAM FIRE

A slam fire is an unintended discharge of a firearm that occurs as a round is being loaded into the chamber. AR style rifles have a free-floating firing pin, which is capable of a slam fire, **ALWAYS LOAD YOUR RIFLE WITH THE BARREL POINTED DOWN RANGE AND/OR IN A SAFE DIRECTION.**

## 2.1 HANG FIRE

If your firearm fails to fire, hold it, keep it pointed towards the target and wait 30 seconds. If a hang fire has occurred, the round will fire within 30 seconds. If the round does not fire:

1. Remove magazine
2. Eject round and examine the primer.
  - If firing pin indent is light, misaligned or non-existent, have your firearm examined by a competent gunsmith.
  - If firing pin indent on primer appears normal then assume its faulty ammunition, dispose of the misfired round, reload and resume firing.

## 2.3 SQUIB

1. If an audible “POP” or reduced recoil is experienced during firing, immediately CEASE FIRE, DO NOT APPLY IMMEDIATE ACTION.
2. Remove the magazine
3. Lock the bolt to the rear
4. Place the selector lever on the “SAFE” position.
5. Visually inspect and/or insert a cleaning rod into the bore to ensure there is not a projectile lodged in the bore. If a projectile is lodged in the barrel of the weapon, do not attempt to remove it, contact a gunsmith.

## 3. IMMEDIATE ACTION

While firing a stoppage may occur, immediate action can be used to clear the weapon and get it back into service rapidly. Immediate action steps:

1. PUSH –PULL: Push up, then pull down on the magazine to ensure its properly locked into place
2. PULL: Pull the charging handle to the rear and hold
3. OBSERVE: Observe the chamber for any blockages
4. RELEASE: If the chamber is clear release the charging handle
5. TAP: Tap the forward assist
6. SQUEEZE: Squeeze the trigger



Figure 1

#### 4. CONTROLS / COMPONENTS

- 1 – Bolt Catch / Bolt Release
- 2 – Charging Handle
- 3 – Safety Selector Lever
- 4 – Trigger
- 5 – Takedown Pin
- 6 – Pivot Pin
- 7 – Forward Assist
- 8 – Dust Cover
- 9 – Ambidextrous Bolt Release
- 10 – Magazine Release
- 11 – Magazine Well Extension
- 12 – Magazine Well Extension Takedown Pin

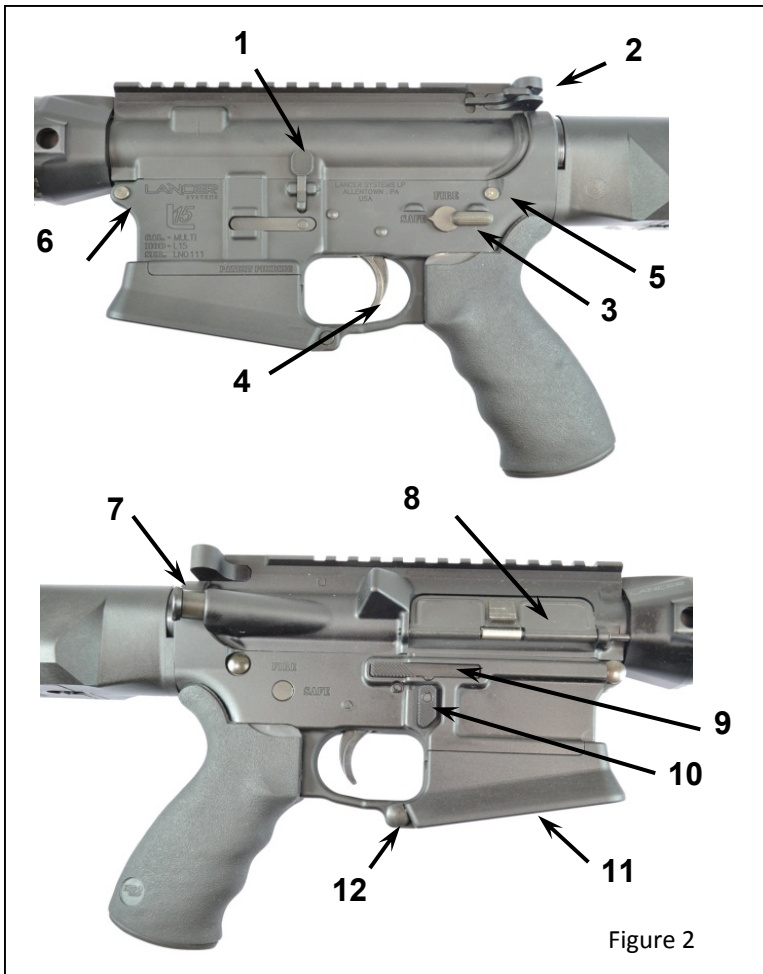

Figure 2

## 5. SAFETY SELECTOR

The L15 rifle safety selector lever has two positions, "FIRE" and "SAFE". When set to "FIRE" the firearm will fire a single shot each time the trigger is squeezed. When set to "SAFE" the rear of the trigger is mechanically blocked pre-venting the hammer from being released.

- "SAFE" Rifle will not fire. Selector lever cannot be on safe unless rifle is cocked. Always place on SAFE when loading and unloading.
- "FIRE" Rifle will fire one round each time the trigger is pulled.



### 5.1 FUNCTION CHECK - SAFE

Note: Remove magazine and make sure your rifle is unloaded and there is no ammunition in the chamber.

1. Point in safe direction.
2. Pull charging handle to rear and release.
3. Place on safe.
4. Pull trigger. The hammer should not fall.

### 5.2 FUNCTION CHECK - FIRE

Note: Remove magazine and make sure your rifle is unloaded and there is no ammunition in the chamber.

1. Point in safe direction.
2. Place selector on fire.
3. Pull trigger and hold to rear. The hammer should fall.
4. Pull charging handle to rear and release.
5. Release trigger and pull again. The hammer should fall.

## **6. LOADING THE RIFLE**

### **6.1 LOADING THE RIFLE – OPEN BOLT**

1. Lock the bolt open; pull charging handle rearward, press bottom of bolt catch & allow bolt to move forward until it engages bolt catch.
  2. Return the charging handle to fully forward until it locks and remove finger from bolt catch.
  3. Set selector to “SAFE” position.
  4. Insert the loaded magazine into magazine well, push it in until it stops and is retained by magazine catch. Pull down on the magazine to ensure its locked into place.
  5. Release the bolt, your L15 rifle has 2 bolt release levers; the flat portion of the bolt catch and the ambidextrous bolt release lever.
    - With the rifle pointed in a safe direction press in on top of bolt catch. This will release the bolt and carrier and move a round into chamber.
- OR
- With the rifle pointed in a safe direction press, with your trigger finger, press the ambidextrous bolt release lever. This will release the bolt and carrier and move a round into chamber
6. The rifle is now loaded with a round in the chamber and the hammer cocked.

### **6.2 LOADING THE RIFLE – CLOSED BOLT**

1. Insert loaded magazine into magazine well and push it in until it stops and is retained by magazine catch. Pull down on the magazine to ensure it is locked into place.
2. Pull the charging handle to the rear and release. It's important you pull the charging handle completely to the rear and release. Failure to pull the charging handle completely to the rear or if you “ride the charging handle” forward the round may not fully chamber.
3. The rifle is now loaded with a round in the chamber and the hammer cocked.

## **7. UNLOADING THE RIFLE**

1. Set selector to “SAFE” position.
2. Press magazine catch button and remove magazine.
3. Pull charging handle to rear and lock the bolt open; pull charging handle rearward, press bottom of bolt catch & allow bolt to move forward until it engages bolt catch. If a round had been in the chamber it should have been ejected. If last round in magazine had been fired and if the magazine was in place, bolt and carrier should already be held to the rear.



## 8. CLEARING THE RIFLE

1. Place selector on SAFE. If weapon is not cocked, the safety selector lever cannot be pointed toward SAFE.
2. Remove magazine; press the magazine release button, the magazine should eject.
3. Lock the bolt open; pull charging handle rearward, press bottom of bolt catch & allow bolt to move forward until it engages bolt catch. Return charging handle to forward. If you haven't before, place on SAFE.
4. Visually inspect the chamber to ensure it contains no ammunition.
5. With the safety selector on SAFE, release the bolt. Your L15 rifle has 2 bolt release levers; the flat portion of the bolt catch and the ambidextrous bolt release lever.
  - With the rifle pointed in a safe direction press in on top of bolt catch. This will release the bolt and carrier.OR
  - With the rifle pointed in a safe direction press, with your trigger finger, press the ambidextrous bolt release lever. This will release the bolt and carrier.

## 9. BARREL BREAK-IN

The following is a guide to "break-in" based on our experience. This is not a hard and fast rule, only a guide. Some barrel, chamber, bullet, primer, powder, pressure, velocity etc. combinations may require more cycles some less.

Initially you should perform the shoot-one-shot-and-clean cycle for five shots. If fouling hasn't reduced, fire five more cycles and so on until fouling begins to drop off. At that point shoot three shots before cleaning and observe. If fouling is reduced, fire five shots before cleaning. Do not be alarmed if your seating depth gets longer during break in. This is typical of the "high" spots in the throat being knocked down during this procedure. It is not uncommon for throat length to grow .005"-.030" from a fresh unfired chamber during break in.

L15 Competition, L15 Super Competition & L15 Sharp Shooter – Stainless Steel Barrel

- 5-10 one-shot cycles
- 1 three-shot cycle
- 1 five-shot cycle

L15 Sporter - Chrome Moly Barrel

- 5 - 25 - one-shot cycles
- 2 - three-shot cycles
- 1 - five-shot cycle

## 10. ADJUSTING THE STOCK

The stock on the L15 Sporter can be adjusted to increase or decrease the length of pull.

1. Press in the latch to disengage the lock
2. Rotate the lock away from the rifle
3. Slide the butt place to the desired length
4. Rotate the lock toward the rifle until the latch engages

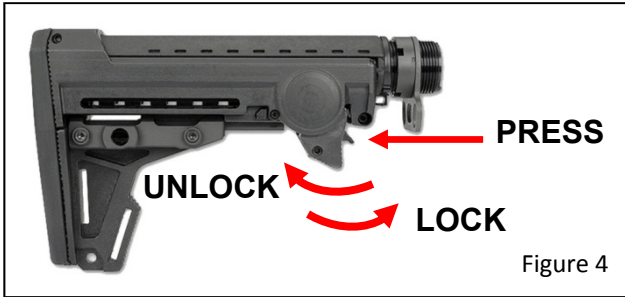

## 11. CHANGING THE MAGAZINE WELL EXTENSION

NOTE: The Lancer L15 magazine well extension has a patented removable magazine well extension system.

1. Press magazine well extension takedown pin in from left (it may be necessary to use a punch as the fit magazine well extension and the lower receiver may be very tight). Pull it out the right side until it comes to a positive stop.
2. Slide the magazine well extension forward, toward the front of the rifle, until it clears rails of the lower receiver.
3. Prepare the new magazine well extension by pressing and sliding the takedown pin from the left.
4. Slide the new extension onto the lower receiver until the takedown pin lines up with the mounting hole in the receiver.
5. Push the takedown closed (it may be necessary to use a punch as the fit magazine well extension and the lower receiver may be very tight).

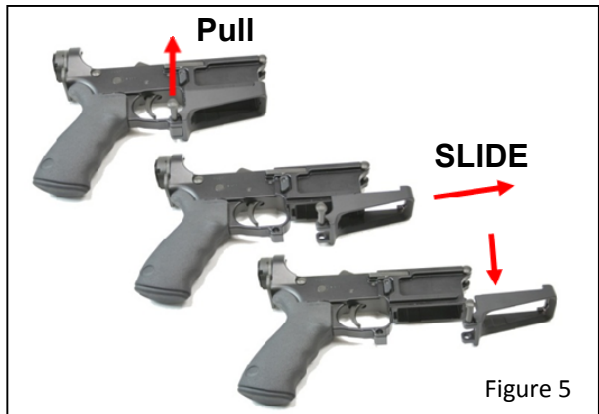

## 12. MOUNTING SIGHT AND OPTICS

Lancer L15 Rifles have a flattop upper receiver featuring a MIL-STD-1913 Picatinny rail on top. The rail will accept mounts with designed for Picatinny rail or Weaver rail.

The Lancer L15 Sporter has a MIL-STD-1913 Picatinny sight rail on the end of the handguard for a removable front sight post (not included with the rifle). The sight rail is aligned with the Picatinny rail on top of the receiver.

## 13. MAINTENANCE

### 13.1 FIELD STRIPPING & DISSASSEMBLY

1. Press take down pin in from left of lower receiver (it may be necessary to use a punch as the fit between upper and lower may be very tight). Pull it out the right side until it comes to a positive stop.
2. Pivot upper receiver up and away from the lower receiver.
3. Press front pivot pin in from left side of lower receiver and pull out right side until it comes to a positive stop.
4. Separate the upper and lower receivers.
5. Pull charging handle to rear and remove bolt and carrier assembly.
6. Remove charging handle by pulling it backwards to keyway and down out of receiver.

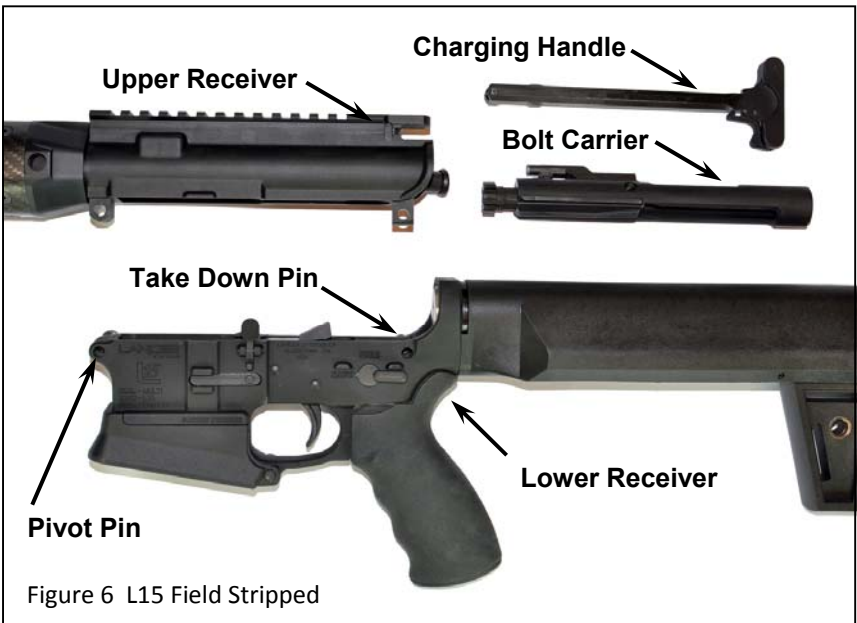

### 13.1.1 BOLT & BOLT CARRIER COMPONENTS

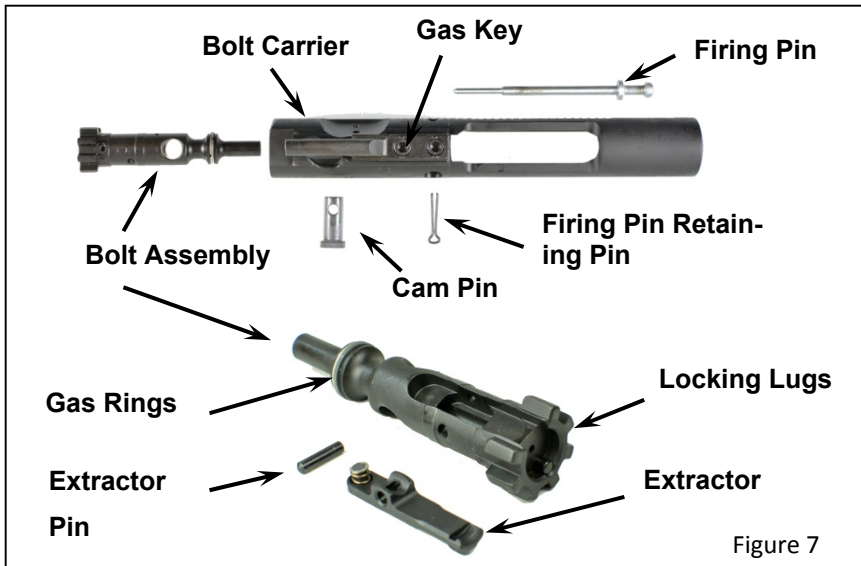

### 13.1.2 BOLT CARRIER DISSASSEMBLY

1. Push in firing pin retaining pin right-to-left of bolt carrier and remove it by pulling it out to the left.

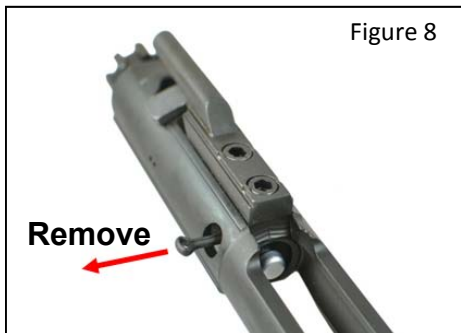

2. Tilt bolt face up and remove firing pin.
3. Push bolt in towards the carrier until it rotates and comes to a stop, then turn cam pin 90°

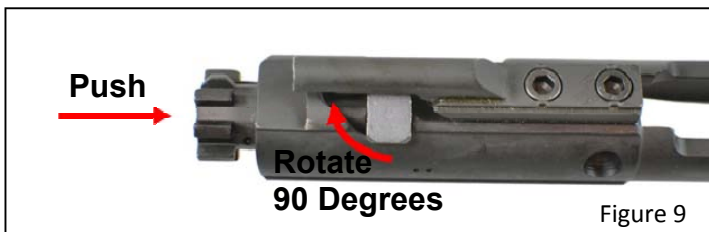

- Remove cam pin by lifting it out away from bolt and carrier.

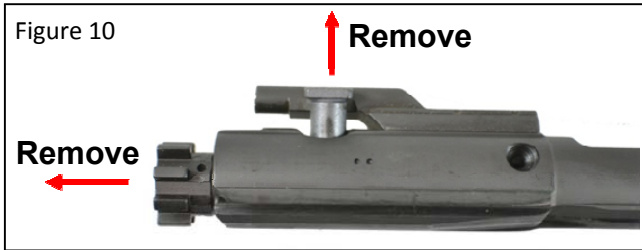

- Pull bolt forward out of carrier.
- With a punch, remove the extractor pin from the bolt assembly.



- Remove the extractor. It is unnecessary to remove the spring from extractor.

### 13.1.3 BUFFER REMOVAL

- Depress buffer, maintaining pressure as buffer is under spring tensions, to prevent it from being ejected when buffer retainer is depressed.
- Depress buffer retainer to permit buffer and spring to move forward.
- Then depress hammer to allow the buffer and spring to continue to move forward and be removed from receiver extension.

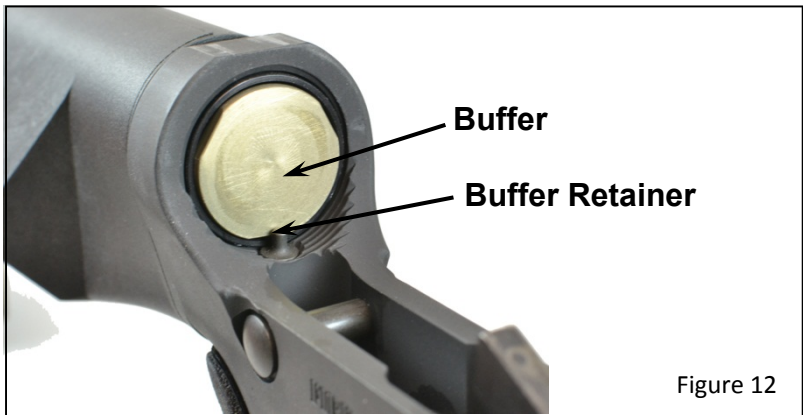

### **13.1.4 HANDGUARD REMOVAL**

**NOTE: It's not necessary to remove the handguard for normal maintenance, only remove the handguard tube when necessary.**

1. Secure the rifle or upper receiver in a receiver block
2. Remove the 5 handguard retention screws (if the handguard has a full length sight rail, the rear sight rail retention screw will need to be removed)
3. Slowly and firmly pull the carbon-fiber handguard tube away from the upper receiver until it clears the upper receiver extension. The fit between the carbon-fiber handguard tube and the upper receiver extension is a light press fit, removal will require a forceful, straight pull until the upper receiver extension is cleared.

**NOTE: Do not strip your firearm further than previously described. If additional maintenance is necessary consult a competent gunsmith. Your rifle is now stripped for cleaning.**

## **13.2 CLEANING & INSPECTION**

### **CLEANING GENERAL NOTES:**

- Use good quality, name brand chemical cleaners; Rifle Bore Cleaner or CLP.
- Clean and lubricate your bore with proper fitting patch/jag combination for your particular bore size and good quality properly sized nylon or bronze brushes.
- Do not use wire brush or any type of abrasive material to clean aluminum surfaces.
- Inspect the components prior to lubricating.

### **13.2.1 LOWER RECEIVER**

- Clean areas of powder fouling, corrosion and dirt.
- Wipe dirt from trigger mechanism.
- Clean buffer and inside lower receiver extension.

### **13.2.2 BOLT CARRIER GROUP**

- Outer & inner surfaces of bolt carrier
- Carrier key
- Firing pin recess and firing pin
- Firing pin hole
- Carbon deposits & dirt from locking lugs
- Areas behind bolt ring and under lip of extractor

### **13.2.3 CARBON-FIBER HANDGUARD**

- Clean with soap and water, cleaning solvents will not damage the carbon-fiber.

### 13.2.4 UPPER RECEIVER / BARREL

- All areas of powder fouling, corrosion, dirt and rust.
- Bore & chamber, Locking lugs and Gas tube;

1. Use cleaning rod, bore brush, and Rifle Bore Cleaner or CLP. Run rod through chamber and out through compensator / flash suppressor. Do not reverse direction of the bore brush while in the barrel.

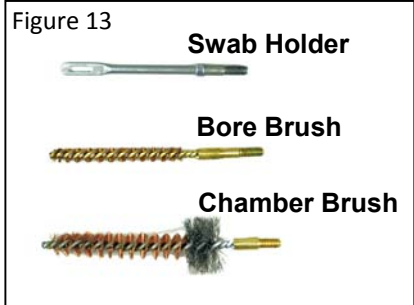

2. Install chamber brush on cleaning rod, dip in Rifle Bore Cleaner or CLP, and insert in chamber and locking lugs. Clean by pushing and twisting cleaning rod.
3. Use a bore brush to clean outside surface of protruding gas tube (get sides and bottom from bottom of upper receiver).
4. Take off bore brush and install swab holder and a swab. Apply Rifle Bore Cleaner or CLP to the swab. Run rod through chamber and compressor / flash suppressor and back.
5. To remove carbon, let Rifle Bore Cleaner or CLP set. Then wipe off clean. A bore brush may be used with care to loosen heavy buildup of carbon.
6. Wipe dry by running rod with swab holder with clean swabs

### 13.2.5 INSPECTION

1. Bolt - Cracks or fractures, especially in the cam pin hole area; bolts that contain pits extending into the firing pin hole need replacing. Do not use a Bolt with cracks
2. Firing Pin - Bent, cracked, blunted, or sharp end
3. Extractor and extractor spring - Check extractor for chipped or broken edges in the area of the lip that engages the cartridge rim. Check that the rubber insert is inside the extractor spring.
4. Cam Pin - Check for cracks or chips. Do not use a cracked Cam Pin.
5. Gas Rings - Inspect for worn gas rings:
  - a) Push the bolt into the carrier.
  - b) Hold carrier assembly vertically with the bolt down; The bolt should not drop down.
  - c) Pull the bolt out to the unlocked position.
  - d) Place the assembly on a table or the deck, balanced on the bolt head; The carrier should not slide down.
  - e) If the assembly fails either of these checks the gas rings should be replaced.

## 13.3 LUBRICATION

### 13.3.1 GENERAL NOTES

1. Lubricate with a light gun oil or CLP
2. The amount of lubrication differs from part to part, see definitions below:
  - Lightly Lube - A film of oil barely visible to the eye.
  - Generously Lube - Heavy enough so that it can be spread with the finger.

### 13.3.2 BOLT CARRIER GROUP

1. Generously Lube
  - a) Outside of the bolt body
  - b) Gas Rings
  - c) Cam Pin
  - d) Slide and Cam Pin area of Bolt Carrier
2. Lightly Lube
  - a) Firing pin
  - b) Firing pin recess in bolt
  - c) Inner and outer surfaces of the bolt carrier
  - d) Extractor and extractor pin
3. Dry the inside of the gas key then apply one drop of CLP or oil

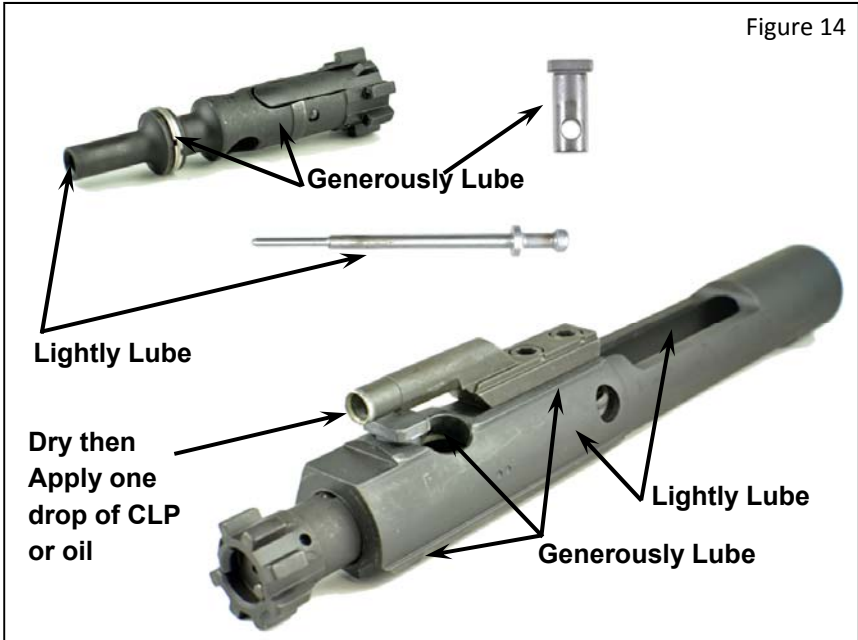



### 13.3.3 UPPER RECEIVER

1. Lightly lube inside of upper receiver, bore and chamber
  - Run a oiled patch through the bore, do not reverse direction
  - Lubricate the locking lugs and chamber
2. Lightly lube the outer surfaces of receiver and barrel.
3. Lightly lube the outside surfaces of the charging handle.

### 13.3.4 LOWER RECEIVER

1. Generously lube
  - a) Pins and detents
  - b) Moving components and pins, Fig 15
2. Lightly lube
  - a) Inside of the buffer tube, Fig 16
  - b) Buffer
  - c) Buffer spring

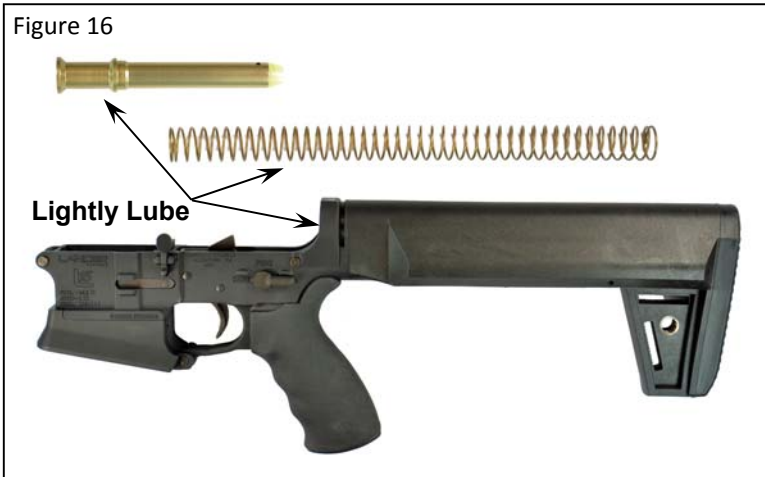
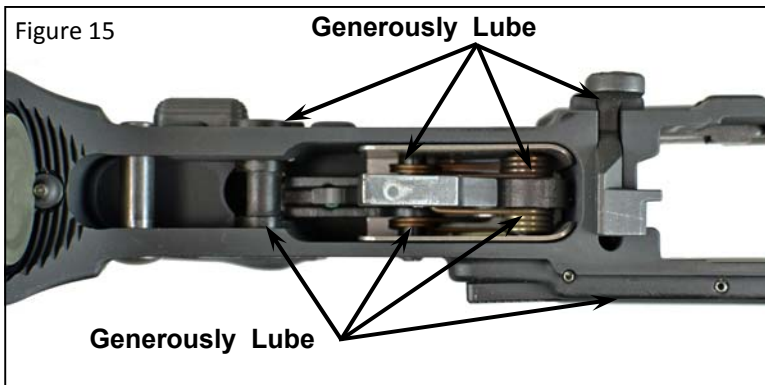

### 13.4 ASSEMBLY

After you have cleaned and lubricated your L15 Rifle re-assemble as follows

#### 13.4.1 BUFFER

1. Place the buffer onto the buffer spring if they have become separated
2. Place the spring into the buffer tube
3. Push the buffer into the buffer tube, compressing the buffer spring, until it clears the Buffer Retainer.
4. Release the buffer, it should stop on the Buffer Retainer.



Figure 17

#### 13.4.2 BOLT CARRIER GROUP

1. Assembly Bolt
  - a) Ensure you have the Bolt, Extractor with extractor spring attached and Extractor Pin, fig 18-1
  - b) Place extractor onto bolt, fig 18-2
  - c) Press down on the extractor, compressing the extractor spring and install the extractor pin, it can be installed from either side, fig 18-3
  - d) Slide the extractor pin through the bolt and extractor until it's flush on or below the bolt surface on both sides, fig 18-4

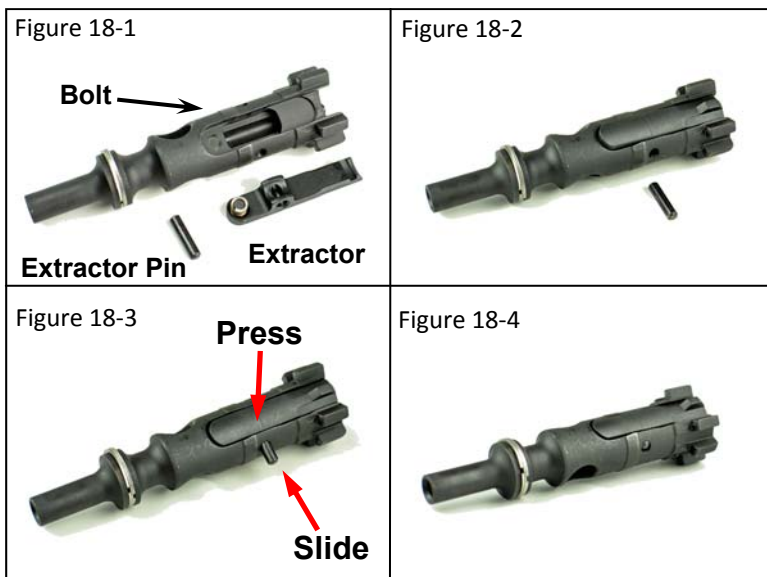

2. Place Bolt in Bolt Carrier
  - a) Place bolt into bolt carrier, slide all the way in.
  - b) Rotate bolt so the extractor is approximately in the 10 o'clock position when viewed from the front. fig 19

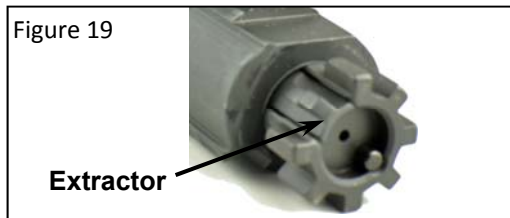

3. Install Cam Pin
  - a) Place cam pin into the bolt, fig 20.1
  - b) Rotate the cam pin so it clears the gas key and push down until the top of the cam pin clears the gas key. fig 20-2
  - c) Rotate the cam pin 90 degrees. fig 20-3

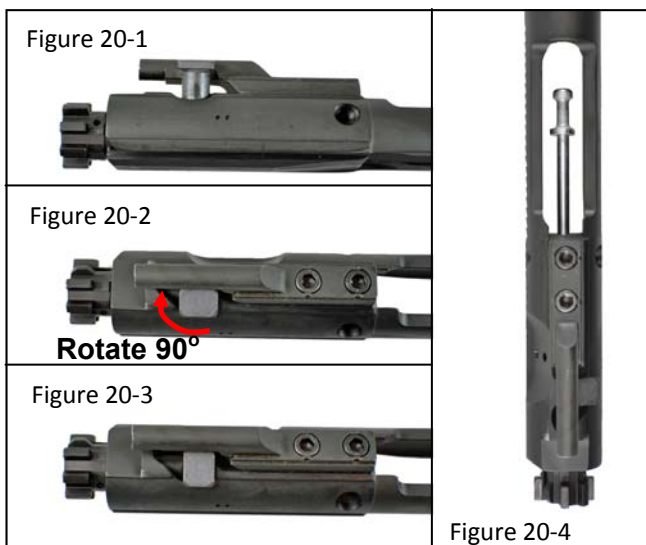

4. Install Firing Pin
  - a) Ensure the bolt is pushed all the way in and the cam pin is rotated as in fig 20-3.
  - b) Tip the bolt carrier up and slide the firing pin from the end. Fig 20-4
  - c) If necessary push the firing pin completely into the bolt.
  - d) Pull the bolt forward, rotating the cam pin under the gas block.

5. Install Firing Pin Retaining Pin
  - a) Install the pin from the side of the bolt carrier with the counter bore.
  - b) Push the pin in until the looped end is completely within the counter bore and does not stick out beyond the edge of the bolt carrier. Fig 21



Figure 21

### 13.4.3 UPPER RECEIVER

1. Install Charging Handle - engage the charging handle into the upper receiver and slide in part way. Fig 22
2. Installing the bolt carrier
  - a) Extend bolt, ensure the top of the cam pin is under the gas key. Fig 21
  - b) With the bolt extended, insert the bolt carrier into the upper receiver, the gas key will fit inside the groove in the charging handle. Fig 23-1
  - c) Slide in the bolt carrier group. Fig 23-2
  - d) Slide the charging handle and bolt carrier group until the bolt goes into battery. Fig 23-3

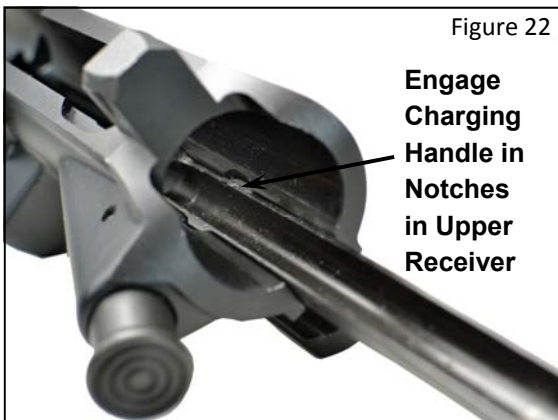
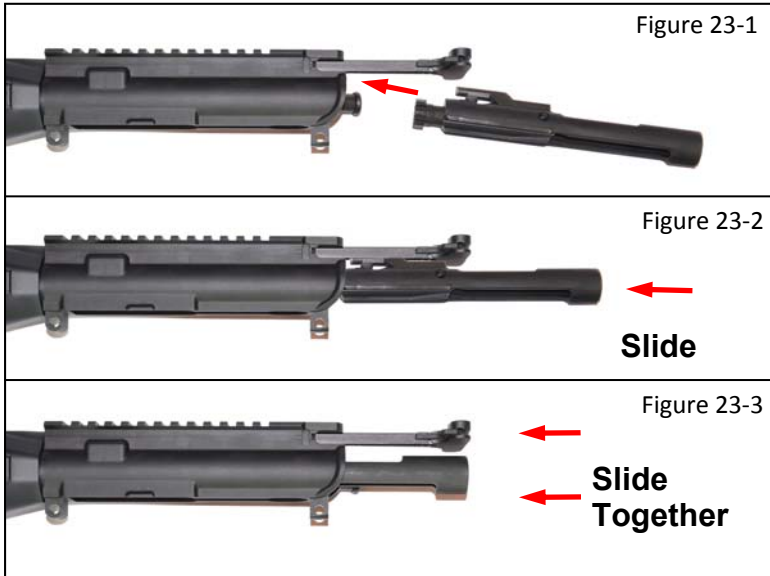

Figure 22



#### 13.4.4 ATTACH UPPER TO LOWER RECEIVER

1. Join the upper and lower receivers, aligning the pivot pin with the corresponding holes in the upper receiver
2. Engage the pivot pin, ensure it locks into place.
3. Ensure the hammer is locked back and the rifle is on safe, if the hammer is up manually push is down until it engages the sear, place the selector on safe.
4. Align the take down pin with the corresponding holes in the upper receiver, engage the take down pin and ensure it locks into place.

#### 13.4.5 PERFORM FUNCTION CHECK, see section 5.1 and 5.2

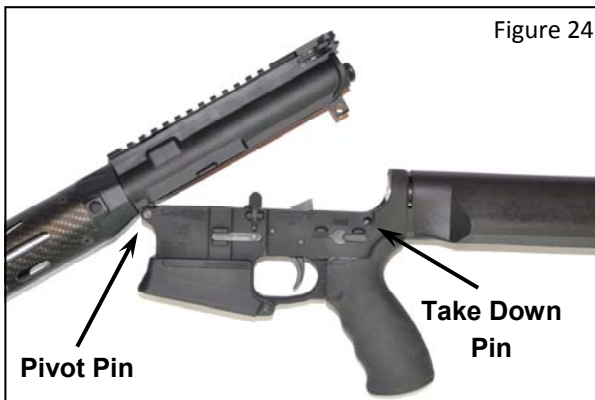

## 14. SPECIFICATION

### L15 Sporter

Caliber.....	5.56mmX45 / .223rem
Barrel.....	16" Lightweight CHF Chrome lined
Twist.....	1:7
Chamber.....	5.56mmX45 NATO
Gas system.....	Mid Length
Flash Hider.....	A2 Flash Hider
Trigger.....	Milspec
Stock.....	F93 Pro stock with heavy buffer
Weight.....	7.2lbs

### L15 Competition

Caliber.....	5.56mmX45 / .223rem
Barrel.....	WOA SS 18" Mid-weight profile
Twist.....	1:8
Chamber.....	5.56mmX45 NATO
Gas system.....	Rifle Length
Compensator.....	Lancer Nitrous Compensator
Trigger.....	CMC 3-1/2lb Trigger
Stock.....	Lancer LCS A1 Fixed Stock
Weight.....	7.7lbs

### L15 Super Competition

Caliber.....	5.56mmX45 / .223rem
Barrel.....	Bartlein SS 17" Mid-weight profile
Twist.....	1:7.7
Chamber.....	223 Wylde
Gas system.....	Rifle Length
Compensator.....	Lancer Nitrous Compensator
Trigger.....	CMC 3-1/2lb Trigger
Stock.....	Lancer LCS A1 Fixed Stock
Weight.....	7.5lbs

### L15 Outlaw

Caliber.....	5.56mmX45 / .223rem
Barrel.....	Bartlein SS 17" Mid-weight profile
Twist.....	1:7.7
Chamber.....	223 Wylde
Gas system.....	Rifle Length
Trigger.....	Geissele SD3G Trigger
Stock.....	Lancer LCS A1 Fixed Stock
Weight.....	6.25lbs

## 15. TROUBLE SHOOTING

PROBLEM	CHECK FOR	SOLUTION
<b>Won't Fire</b>	Selector on SAFE	Move Selector to FIRE
	Firing Pin improperly installed	Assemble correctly
	Dirty firing Pin, too much carbon	Clean
	Defective ammo	Discard
<b>Bolt Won't Unlock</b>	Dirty or carbon fouling	Clean
<b>Won't Extract</b>	Broken Extractor Spring	Contact gunsmith for repair
	Extractor lip fouled with carbon	Clean extractor
	Dirty or corroded ammo	Remove with cleaning rod
	Carbon in chamber	Clean chamber
<b>Won't Eject</b>	Fouled ejector	Clean
	Broken ejector or ejector spring	Contact gunsmith for repair
<b>Won't Chamber</b>	Dirty or corroded ammo	Replace ammo
	Damaged ammo	Replace ammo
	Carbon in chamber	Clean
<b>Won't Feed</b>	Dirty or corroded ammo	Replace ammo
	Dirty Magazine	Clean
	Defective Magazine	Replace
	Too many rounds in magazine	Remove excess
	Magazine not full seated	Adjust magazine catch
<b>Won't Lock</b>	Buffer restricted or dirty	Remove, clean and lube
	Carbon build up in locking lugs	Clean
	Frozen extractor	Remove, clean
	Buffer restricted or dirty	Remove, clean and lube
	Bolt carrier restricted or dirty	Remove, clean and lube
<b>Short Stroke</b>	Gas rings not staggered	Staggered
	Loose gas key	Contact gunsmith for repair
	Carbon or dirt in gas key	Clean
<b>Double Feed</b>	Defective magazine	Replace magazine
<b>Bolt Fails to Lock After Last Round</b>	Dirty bolt catch	Clean
	Defective magazine	Replace
	Check for Short Stroke	See above

## **16. LIMITED WARRANTY**

This Lancer Systems firearm is warranted to the original retail customer for one year from the date of purchase against defects in material and workmanship. All parts and labor or replacement at our option are covered.

Transportation to and from our repair facility, government fees, damage caused by failure to perform normal maintenance, sales outside the United States, damage due to high velocity, high pressure, reloaded or other nonstandard ammunition, or any unauthorized repair, modification, misuse, abuse, or alteration of the product is not covered by this Limited Warranty.

Any implied warranties, including the implied warranties of merchantability and fitness for a particular purpose, are limited to one year from date of purchase. Consequential or incidental damages and/or expenses, or any other expenses are not covered by this warranty.

To obtain warranty performance send your firearm with proof of retail purchase, freight prepaid to: Lancer Systems, 7566 Morris Court, Suite 300, Allentown, PA 18106.

### **16.1 ACCURACY**

To achieve the best results for accuracy follow the barrel break in instructions detailed in section 9. Accuracy is dependent upon many factors such as bullet weight, powder load, rifling twist, rifling lands, operator technique, etc. It usually takes about 200 rounds through the barrel for optimum accuracy.

- The Sporter and Competition barrels are production barrels and typical accuracy can vary from to 1 to 2 M.O.A.
- The Super Competition and Sharp Shooter barrels are precision barrels and 1/2 M.O.A. or better can be achieved, though typical accuracy can vary from 1/2 M.O.A. to 1 M.O.A.

Potential to obtain the above stated accuracy exist, but considering all factors that can affect accuracy, we cannot guarantee a specific group size.



## **16.2 ALTERATIONS AND MODIFICATIONS**

Altering or modifying parts is dangerous and will void the warranty. This L15 Rifle was manufactured to perform properly with the original parts as designed. It is your duty to make sure any parts you buy are made for this rifle and are installed correctly and that neither the replacements nor originals are altered or changed. Your Lancer L15 rifle is a precision tool with many parts that must relate correctly to other parts in order for proper and safe operation. Putting a rifle together wrong or with incorrect or modified parts can result in a damaged rifle, serious personal injury or death to you and others through malfunction. Always have a qualified gunsmith work on your rifle or at least check any work not performed by a gunsmith.

## **16.3 PROBLEMS/RETURNS**

Although we go to great lengths to make a perfect product and get it to you in perfect condition, sometimes things happen! If there is a problem with our product or if shipping damage has occurred, please call us immediately for instructions at (610) 973-2600, visit our website at [www.lancer-systems.com](http://www.lancer-systems.com) or email us at [ls\\_techsupport@lancer-systems.com](mailto:ls_techsupport@lancer-systems.com).

**NOTE:** It is illegal to ship a firearm with ammunition in the firearm or in the same packaging. Firearms and ammunition must be shipped separately. For more information about shipping, call Lancer Systems at (610) 973-2600.



**NOTES:**

# LANCER



Lancer Systems  
2800 Milford Square Pike  
Quakertown, PA 18951  
610-973-2600  
[www.lancer-systems.com](http://www.lancer-systems.com)

**MADE IN**  
  
**U. S. A.**