

SR15-UM-0001 REV 3



KAC
KNIGHTS ARMAMENT

STONER SR-15 E3 MOD 2 5.56 MM NATO CALIBER



OPERATORS MANUAL

phone (321) 607-9900

fax (321) 268-1498

701 Columbia Blvd. Titusville, FL 32780

www.KnightArmCo.com

CAGE Code: 15002

DUNS No. 05-403-8138

TIN: 59-1230657

TABLE OF CONTENTS

SAFETY PRECAUTIONS	i
Cautionary Notes	i
General Handling Precautions	ii
Loading Precautions	iii
Range Precautions	iii
Shooting Precautions	iv
PREPARATION TO USE AND INSTALL	1
Ammunition Selection.....	1
Service Upon Receipt.....	1
OPERATOR INSTRUCTIONS	2
Principles of Operation.....	2-3
Clearing Procedures.....	4-6
Function Check.....	7-8
Filling/Emptying Magazine.....	9
Loading.....	10-12
Unloading.....	13-14
Rifle Disassembly.....	15
Upper Receiver Disassembly.....	16-18
Upper Receiver Assembly.....	19-21
Lower Receiver Disassembly.....	22
Lower Receiver Assembly.....	23
Rifle Assembly.....	24
Magazine Disassembly / Reassembly.....	25
Cleaning.....	26-28
Lubrication.....	29-33
Preventive Maintenance Checks and Services.....	34
Stoppage Reduction	35-36
Troubleshooting	37
DISCLAIMER	38
WARRANTY STATEMENT.....	39
ADDENDUM	40
Back-Up Iron Sights.....	40-42
Zeroing.....	43-45
M-LOK Accessories	46-49
EXPLODED DIAGRAMS.....	50-55

SAFETY PRECAUTIONS

CAUTIONARY NOTES



CAUTION



Read and understand all of the following precautions before removing this firearm from its packaging. If you are unsure about or do not fully understand any part of these precautions or instructions, contact Knight's Armament Company (KAC) at (321) 607-9900 for assistance before loading and/or firing this rifle.

Carefully read this instruction manual which gives basic advice on the proper handling and operation of this firearm prior to loading and firing. Your safety and the safety of others depends on your considered and mature compliance of safe practices.

If unfamiliar with firearms, seek further advice through safe handling courses run by NRA approved instructors, or similarly qualified personnel or organizations.

Use only clean, dry, original high quality commercially manufactured ammunition in good condition in your firearm. The use of remanufactured or hand-loaded ammunition is not recommended as it may severely damage your rifle and/or cause you or others personal injury or death.

If this firearm is carelessly or improperly handled, unintentional discharge could result, which could cause injury, death, or damage to property.

SAFETY PRECAUTIONS

CAUTIONARY NOTES



CAUTION



GENERAL HANDLING PRECAUTIONS

Each of the below steps are to ensure your safety as well as the safety of others. Please adhere to these precautions to avoid unwanted or accidental discharge of weapon.

Always handle your firearm as if it were loaded to avoid accidental discharge which may cause injury, death, or damage to property. Never assume a firearm is unloaded, even if informed by another that it is. Personally verify condition of any firearm with fingers clear of the trigger, safety on, and pointed in a safe direction as per the Clearing Instructions on pages 4-6 of this manual.

Never point a firearm at anything that is not intended to contain a fired projectile.

Keep the trigger and trigger area clear of fingers and any implement that might pull the trigger, until aimed at a target and intending to fire.

Keep selector lever set to safe until aimed at an acceptable target and ready to fire.

Before firing, be sure of target suitability, the foreground and background of the target, and the ability of the backstop to safely contain fired projectiles.

Always ensure your firearm is free of any ammunition, set on safe, and the bolt is locked back before laying it down or handing it to another person. Never leave a loaded firearm unattended.

Always be aware of possible risk from dropping your firearm, as some parts could be damaged. If severe, the firearm may malfunction and cause injury, death, or damage to property. If your firearm has been dropped, have it examined by an armorer prior to the introduction of ammunition.

Instruct all members of the household on the proper handling of firearms and receive training by a qualified instructor on how to treat and use the firearm properly.

Always store your firearms and ammunition in separate locked receptacles, inaccessible to children or others not suitable for access to firearms.

SAFETY PRECAUTIONS

CAUTIONARY NOTES



CAUTION



LOADING PRECAUTIONS

Always check that ammunition is clean and undamaged before firing.

Ensure barrel, bore, chamber, and action are clean and clear of obstructions or debris.

Clean a wet or fouled firearm immediately to ensure that it will function correctly and safely.

Only use high quality ammunition, in good condition.

Forcing damaged ammunition into the chamber could damage your rifle and/or result in injury, death, or damage to property.

RANGE PRECAUTIONS

Ensure target backstop is adequate to stop and contain projectiles and fragments before loading or firing your firearm.

Always have a knowledgeable and responsible person in charge to maintain safety control of the range.

Always carry your firearm unloaded and on safe until preparing to fire. Keep it pointed toward the backstop and ensure no one is downrange when loading, firing, or unloading to eliminate the risk of injury, death, or damage to property from unintentional discharge.

SAFETY PRECAUTIONS

CAUTIONARY NOTES



CAUTION



SHOOTING PRECAUTIONS

Always keep selector lever set to safe when the firearm is loaded, until aimed at a target and intending to fire.

Never operate a firearm while under the influence of drugs or alcohol.

Seek a doctor's advice if you are taking medication to ensure physical and mental fitness to handle firearms safely.

Always wear hearing protection and shooting glasses when shooting or in the presence of firearms being discharged.

Always keep the ejection port clear to ensure the safe ejection of fired and unfired rounds.

Never place fingers or any other body part in the ejection port, as they could be burned by hot metal, or injured by extracted casings or bolt reciprocation.

Never attempt to fire if water is in the barrel. Water can accumulate in the bore if exposed to heavy rain or fog. Clear the firearm (as per directions on page 5-7), open the bolt, and allow water to drain. Clean and dry a wet firearm as soon as possible.

Never shoot at hard surfaces such as rocks or concrete, or a liquid surface such as water. A projectile may ricochet and travel in any direction to strike you or an object you cannot see, causing injury, death, or damage to property. Only high-quality steel targets in good repair, at a safe distance, with appropriate ammunition, are suitable hard-surface targets.

Never walk, climb, or follow a companion with your firearm ready to fire. This will eliminate risk of accidental discharge. When carried in a ready to fire state, hold the firearm so the direction of the muzzle can be controlled in the event of a fall, and keep the selector set to "SAFE".

PREPARATION TO USE AND INSTALL

AMMUNITION SELECTION

KAC firearms are designed to function with a variety of brands and types of factory manufactured ammunition in the appropriate caliber, but not all ammunition will produce the same results. To protect the user from danger and the rifle from damage, KAC does not recommend the use of hand-loads or remanufactured ammunition.

SERVICE UPON RECEIPT



WARNING



Before starting an inspection or performing any maintenance procedures, personally ensure the rifle is clear. (See Clearing Procedures on pages 5-7.) Never squeeze the trigger until you have cleared the rifle. Always check the chamber to ensure it is empty before touching the trigger. Check for obstructions in the bore before loading and chambering a round. Never keep or allow live ammunition near administrative, cleaning or maintenance areas.



NOTE: Verify the contents of the shipment are correct and complete.



Clear and field strip rifle to ensure there are no missing parts.

Check system case for signs of damage. Conduct safety check and inspect the equipment for damage that may have occurred during shipment.

Inspect contents of system case against the shipping documents and/or the rifle system parts list in the exploded diagrams located in this manual.

Perform safety and functional checks.

Clean the rifle. When finished, inspect bore for obstructions. Do not leave cleaning patches in the bore. Inspect and lubricate rifle.

If you have questions or concerns regarding your firearm, contact:
Knight's Armament Company, 701 Columbia Blvd. Titusville, Florida 32780
Telephone: (321) 607-9900, Fax: (321) 268-1498, Web: www.KnightArmCo.com
Email: info@knightarmco.com or sales@knightarmco.com

OPERATOR INSTRUCTIONS

PRINCIPLES OF OPERATION

FIRING

Safety is rotated to "FIRE". Moving the trigger to the rear releases the hammer from the sear. The hammer springs forward under spring tension to strike the firing pin, and the tip of the firing pin strikes the cartridge primer. The primer detonates from the firing pin impact and ignites the propellant inside the cartridge case. High pressure develops inside the case as the powder burns, causing the cartridge case to expand, forming a gas-tight seal within the chamber. The bullet is pushed from case, accelerated through the barrel, and out of the muzzle.

UNLOCKING

Expanding gas pressure enters the gas tube through a port in the forward area of the barrel. This gas pressure travels through the gas tube into the gas key located on the bolt carrier. Via the gas key, high pressure gas enters the carrier interior, trapped within the expansion chamber of the bolt carrier and the bolt rings at the front. Consequently, expanding gas pressure pushes the carrier to the rear, away from the bolt. As this gas continues to expand, (the bullet has already left the barrel) the bolt carrier continues to move rearward overcoming the force of the action (recoil) spring. The cam groove of the bolt carrier acts on the bolt cam pin which in turn causes the bolt to rotate and the bolt lugs to disengage from the barrel extension locking lugs.

EXTRACTION

As the bolt now begins movement to the rear, the lip of the extractor, which is hooked on the rim of the cartridge case, pulls the case out of the chamber. The lip maintains its grip on the rim of the case through force applied by the extractor spring as the bolt passes by the ejection port.

EJECTION

As the case clears the barrel extension, the stored energy of the ejector springs are applied to the rim of the cartridge case by the ejector plungers. The plungers complete their action as the case clears the ejection port, and the case is rotated free of the extractor lip. This sequence throws the case through the ejection port and clear of the rifle.

OPERATOR INSTRUCTIONS

PRINCIPLES OF OPERATION (continued)

COCKING

The thrust of the carrier assembly from the injection of expanding gases is so great that it continues to move the carrier and bolt assembly fully to the rear of the receiver extension (buffer tube), against the force of the action spring and buffer. As these parts move to the rear, the bottom surface of the carrier passes over the face of the hammer, forcing it back and down against the force of the hammer spring. With the trigger retained to the rear by the operator's finger pressure, the hook of the disconnecter engages the rear hook of the hammer, holding the hammer down and to the rear. The action spring is now fully compressed and prepared to thrust the recoiling mass (buffer, bolt carrier and bolt assembly) forward.

FEEDING

As the bolt and carrier begin moving forward under force of the action spring, the lower feed lug of the bolt strikes the base of the top cartridge in the magazine. The force of the bolt carrier group strips a round from the magazine feed lips. As the round moves forward the tip of the bullet slides up one of the two feed ramps of the barrel extension, toward the chamber. The angle of the feed ramp helps force the round up and into the chamber as the bolt continues to move it forward in the feeding cycle.

CHAMBERING

Chambering occurs when the cartridge is fully forward in the chamber. If there is an obstruction in the chamber, the cartridge case will not fit the chamber properly and the bolt will be prevented from locking.

LOCKING

With a cartridge fully in the chamber, the bolt has fully entered the barrel extension and has ceased forward movement. Also at this time, the extractor lip has snapped over the rim into the extractor groove of the cartridge case and the ejectors and their springs are fully compressed. The carrier, however, continues forward under continued force of the action spring and through action of its "dog leg" cam pin groove on the cam pin, causes the bolt to rotate. Rotation of the bolt moves its locking lugs into alignment with the barrel extension locking lugs. When this rotation of the bolt is complete, the bolt is locked. If the bolt carrier is slightly out of battery (bolt not fully locked), the firing pin will be prevented from reaching the primer even with a blow of the hammer. (See Firing on page 2.) As the shooter releases the trigger for the next shot, the firing sear (trigger sear) enters the hammer sear notch through tension from the trigger spring; simultaneously, the disconnecter releases the rear hammer hook.

With the hammer fully cocked and the trigger sear engaged, the rifle is ready to fire again or be placed on "SAFE".

OPERATOR INSTRUCTIONS

CLEARING PROCEDURES

WARNING



If the weapon fails this procedure, do not fire it. Have it inspected by an armorer or call KAC at (321) 607-9900. All safety checks must be done with the firearm unloaded and with no ammunition present.



- Point rifle in a safe direction.
- Attempt to rotate safety selector to the "SAFE" position.

Selector levers are located on the left and right sides of the lower receiver. They have two positions, "FIRE" and "SAFE". When set to "FIRE", the firearm will fire a single shot each time the trigger is pulled. When set to "SAFE" a cam bears on the rear portion of the trigger preventing it from being pulled and preventing the hammer from being released.

Safe Position

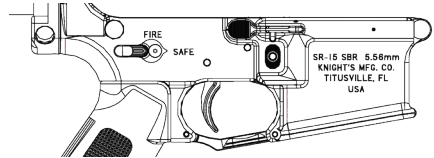

Fire Position

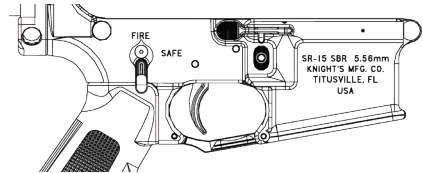

NOTE: If hammer is not cocked, selector will not fully rotate to "SAFE".



If a magazine is present:

- Press magazine release button, allowing magazine to drop free or pull magazine down and out of the rifle.

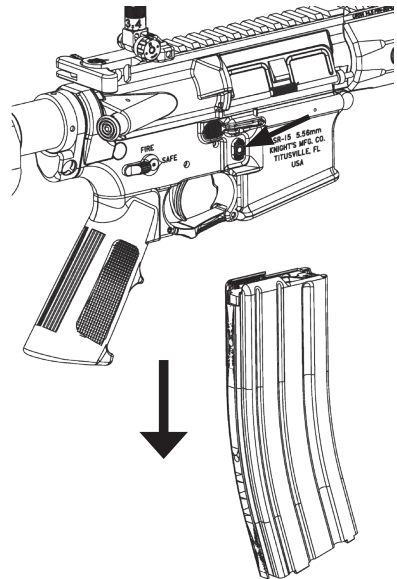

OPERATOR INSTRUCTIONS

CLEARING PROCEDURES

- Lock the bolt open by pulling the charging handle fully to the rear. Depress bottom portion of bolt catch and hold. Allow bolt to move forward slightly by slowly releasing charging handle. The bolt should engage the catch lug (this can be observed through the ejection port).

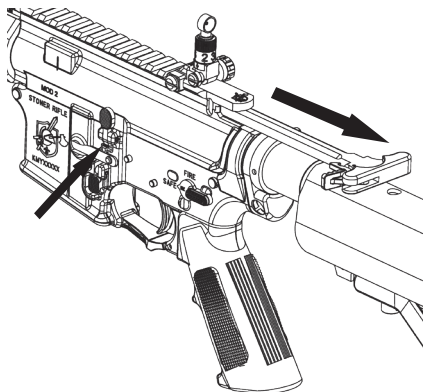

- Once the bolt is locked to the rear, return the charging handle forward until it locks into position.

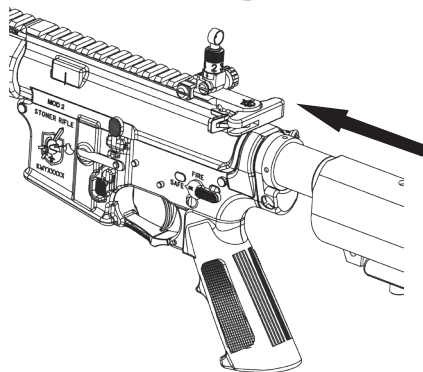

NOTE: If the selector could not be rotated to “SAFE” position initially, do so now.



- Ensure the selector is rotated to the “SAFE” position.

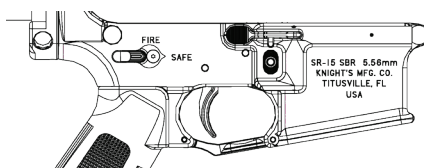

OPERATOR INSTRUCTIONS

CLEARING PROCEDURES

- Visually inspect and verify that the chamber is clear and no ammunition is present in the rifle.

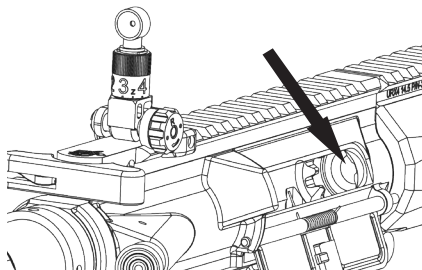

NOTE: The rifle is now clear; no magazine inserted and chamber free of ammunition.



- Return the bolt to the fully forward (locked) position by pulling the charging handle fully to the rear and releasing, or by depressing the bolt release.

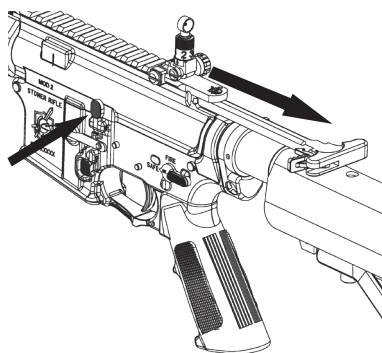

- The bolt release is present on both the left and right sides of the receiver.

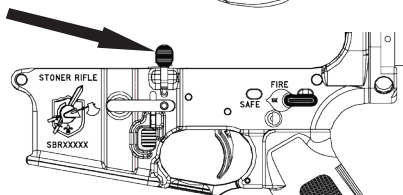

Left Side Bolt Release

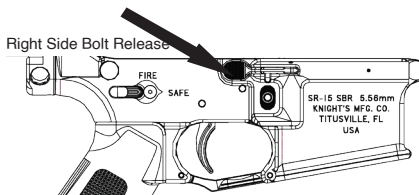

Right Side Bolt Release

OPERATOR INSTRUCTIONS

FUNCTION CHECK

WARNING



All safety checks must be done with the weapon unloaded and no ammunition present. Ensure no ammunition is present in the firearm or in any magazine that will be checked for function. If the rifle fails this procedure, do not introduce ammunition; have the weapon inspected by an armorer or call KAC at (321) 607-9900.



- Follow the “Clearing Procedures” as stated to ensure that the firearm is clear.

- Set safety selector to “SAFE”.

- Pull the charging handle fully to the rear and release.

- Pull trigger. (Hammer should not fall.)

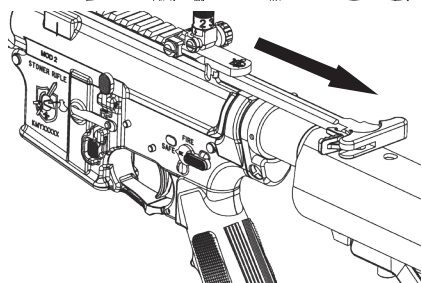
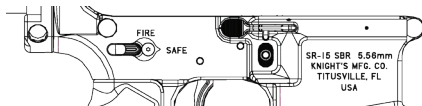

- Set safety selector to “FIRE”.

- Squeeze trigger and maintain sufficient pressure to retain it to the rear. (Hammer should fall.)

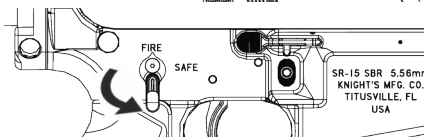

- Pull the charging handle fully to the rear, and release. (Hammer should not fall.)

- Release trigger. (Hammer should not fall.)

- Apply rearward pressure to the trigger. (Hammer should fall.)

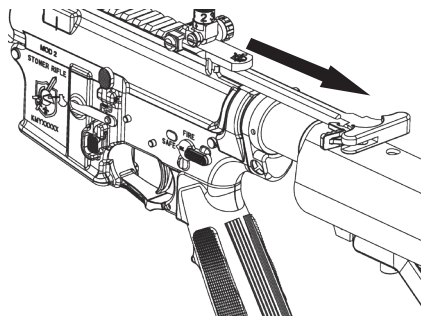

- Pull the charging handle fully to the rear and release.

- Set selector to “SAFE”.

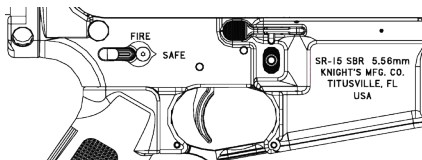

OPERATOR INSTRUCTIONS

FUNCTION CHECK

NOTE: The 2-stage trigger should exhibit a “first” stage of initial take-up of slack, then a heavier “second” stage that subsequently releases the hammer. 2-Stage triggers that do not exhibit a distinct first and second stage trigger pull are not safe to load and fire; contact Knight’s Armament Company at 321-607-9900 or armorer prior to use.

MAGAZINE FUNCTION CHECK

- Ensure that all magazines to be verified for proper function are empty of all ammunition.
- With bolt forward, insert empty magazine into the magazine well.
- Firmly press the magazine into the magazine well until an audible/tactile click indicates that the magazine is seated.
- Pull on magazine to ensure that it is properly retained.
- Pull charging fully to the rear, and return to the forward position. Bolt should be retained in the rearward position.
- Check the function of both the left and right bolt releases by releasing the bolt with both controls.
- With the bolt to the rear, ensure that the magazine drops free using either the right or left side magazine release.

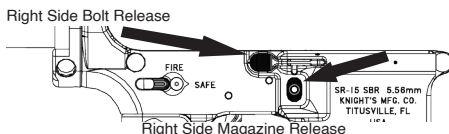
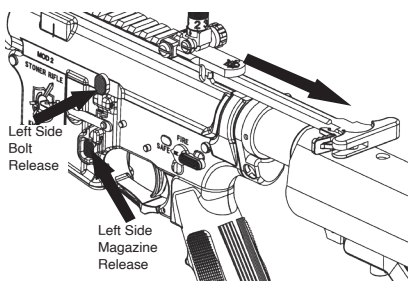
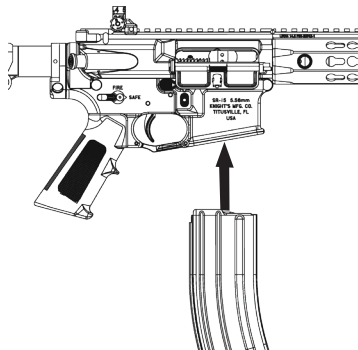

NOTE: Some magazines may not initially drop free from the magazine well. Repeatedly inserting and extracting the magazine will smooth out contact points to permit drop-free function, or the user can lightly polish or sand the contact point at their own risk.

- Repeat with all magazines that will be used with the system.

OPERATOR INSTRUCTIONS

FILLING MAGAZINE



CAUTION
Always check ammunition to ensure it is clean and undamaged. Forcing damaged ammunition into the chamber could damage the firearm and could result in injury, death or damage to property.



- Do not attempt to load or fire damaged ammunition. Check every cartridge for dents, scoring, and other signs of damage.
- Place a round between the feed lips of the magazine with the bullet forward, toward the short side of the magazine.
- Press the round down and toward the back of the magazine until it is held by the feed lips and seated fully rearward.
- Place the next round on top of the previous round and repeat until magazine contains the desired amount of ammunition.

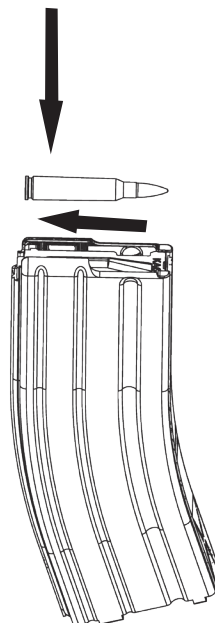

EMPTYING MAGAZINE

- Strip one round at a time out of the magazine by pushing on the cartridge rim. Do not bend or deform magazine lips when stripping rounds from magazines.
- An alternative method is to push top round slightly forward and depress the base of the second round under it. This relieves the pressure on the top round making it easier to remove.

OPERATOR INSTRUCTIONS

LOADING

BOLT CLOSED LOAD

- Point muzzle in a safe direction with the selector on "SAFE".

- Insert magazine into the magazine well, with bullets facing forward toward the muzzle.

Press the magazine firmly upward into the magazine well until an audible/tactile click indicates that the magazine catch is engaged.

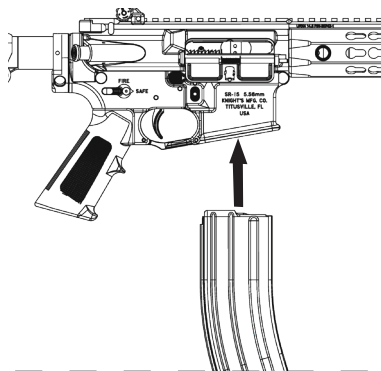

NOTE: It may be difficult to seat a completely full magazine. In this event, apply firm upward pressure to the base of the magazine until it fully seats.

- Pull downward on the magazine to ensure it is fully seated and retained by the magazine catch.

Making Ready from Bolt Closed Load

- Pull the charging handle fully to the rear and release.
- The rifle is now loaded with a round in the chamber, ready to fire.
- Close ejection port door to prevent foreign material from fouling the bolt carrier.

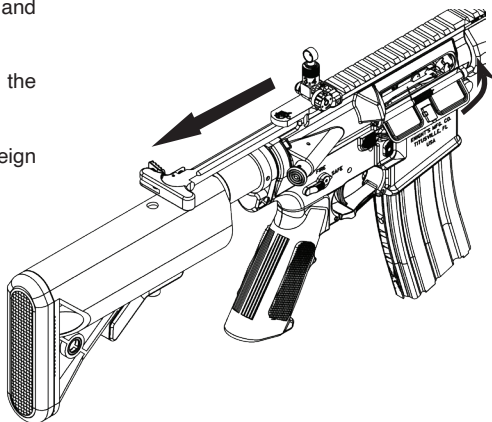

OPERATOR INSTRUCTIONS

LOADING

BOLT OPEN LOAD

- Point weapon in a safe direction and ensure the selector is on "SAFE".
- If the bolt is not already held in the open position, lock the bolt to the rear by depressing the bottom of the bolt catch while pulling back on the charging handle.
- Return the charging handle to the fully forward position.

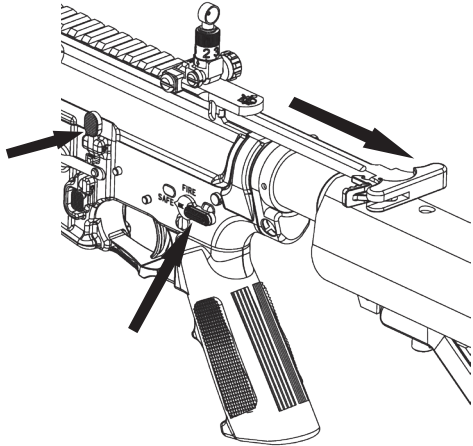

- Insert magazine into the magazine well, with bullets facing forward toward the muzzle.
- Press the magazine firmly upward into the magazine well until an audible/tactile click indicates the magazine catch is engaged.
- Pull downward on the magazine to ensure proper seating and retention by the magazine catch.

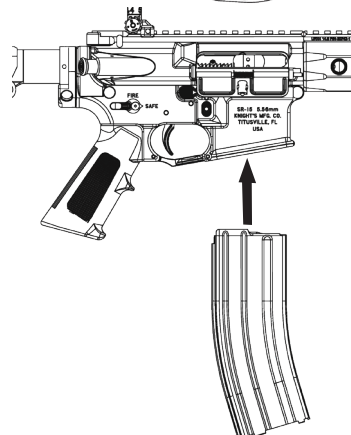
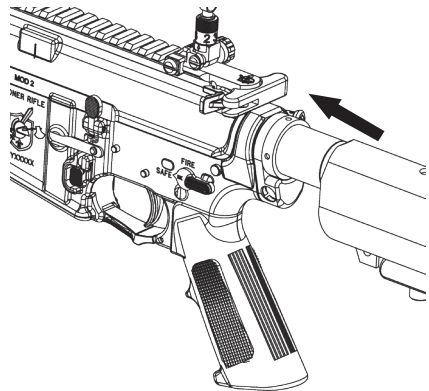

OPERATOR INSTRUCTIONS

LOADING

Making Ready from Bolt Open Load

- Press the bolt release on either the left or right side of the receiver firmly toward the receiver (bolt should go forward).

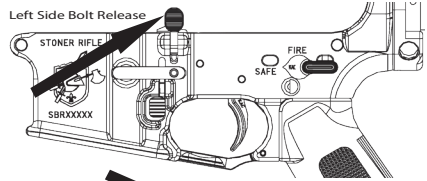

- The rifle is now loaded with a round in the chamber, ready to fire.
- Close ejection port door to prevent foreign material from fouling the bolt carrier.

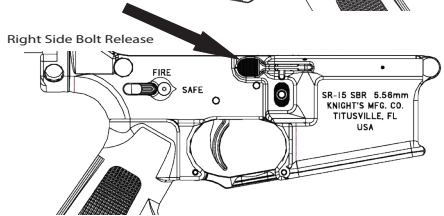

OPERATOR INSTRUCTIONS

UNLOADING

- Point rifle in a safe direction.
- Rotate safety selector to the “SAFE” position.
- Press magazine release button, allowing magazine to drop free or pull magazine down and out of the rifle.

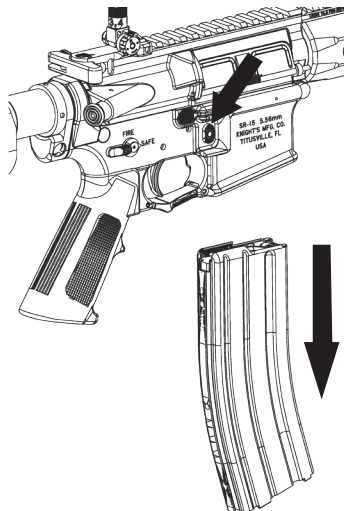

- If the bolt is in the forward position, lock the bolt open by pulling the charging handle fully to the rear. Depress bottom portion of bolt catch and hold. Allow bolt to move forward slightly by slowly releasing charging handle. The bolt should engage the catch lug (this can be observed through the ejection port).

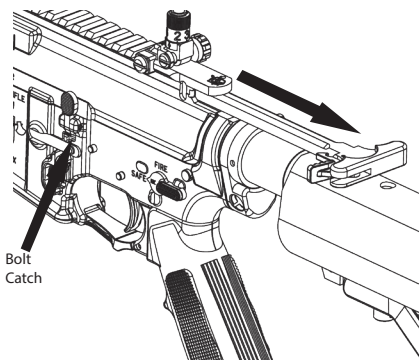

OPERATOR INSTRUCTIONS

UNLOADING

- With the bolt locked to the rear, return the charging handle forward until it locks into position.

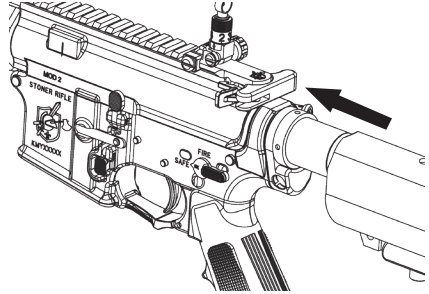

- Visually inspect and verify the chamber is clear and no ammunition is present in the rifle.

The rifle is now clear; no magazine and chamber free of ammunition.

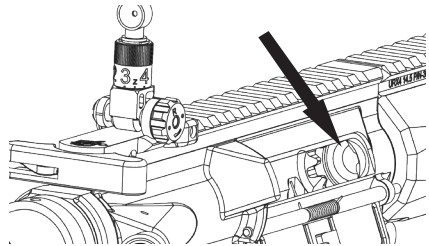

- Return the bolt to the fully forward (locked) position by pulling the charging handle fully to the rear and releasing, or by depressing the bolt release.

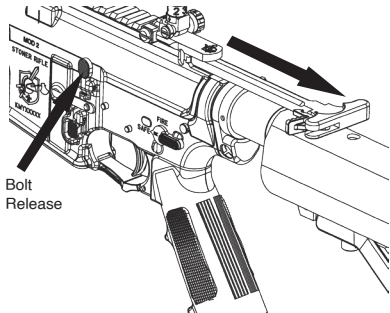

Bolt Release

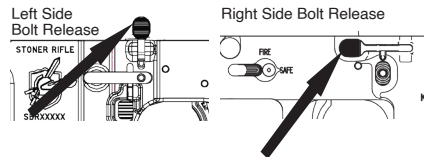

OPERATOR INSTRUCTIONS

RIFLE DISASSEMBLY

NOTE: For detailed cleaning or in the event of functional problems, the lower receiver can be separated from the upper by pivoting it downward after pushing out the take down pin. This provides access to the mechanism and separates the firing mechanism from other components so a cocked hammer could not strike the firing pin. Never open or separate the upper receiver from the lower if a round is in the chamber or the rifle is loaded, as serious injury or death may occur as in the case of a hang-fire or cook-off with the receivers open or separated.

CAUTION

When receivers are open or separated, never allow the hammer to spring forward against receiver wall/bolt catch, as this can damage the receiver and bolt catch. When it is necessary to lower the hammer, retard it from springing forward as the trigger is pulled.

- Ensure rifle is clear and the bolt carrier group is in the fully forward position.
- Pull take down and pivot pins to the right, until the pins are stopped by the internal detents, and separate the upper and lower receivers.

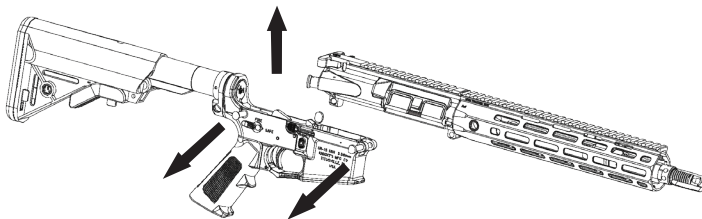

OPERATOR INSTRUCTIONS

UPPER RECEIVER DISASSEMBLY

BOLT AND CARRIER DISASSEMBLY

- Invert the upper receiver so the muzzle is facing away from the user and the upper receiver lugs are facing upward.
- Pull the charging handle fully to the rear.

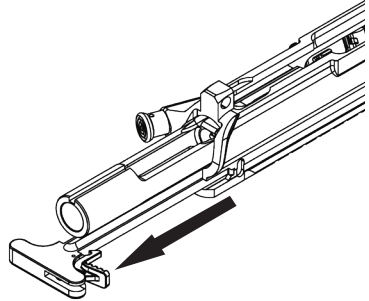

- Remove the bolt carrier assembly by pulling it to the rear and lifting it clear of the charging handle channel.

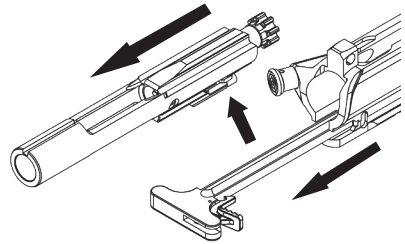

- Ensure the charging handle is fully to the rear, lift upward, freeing the slider ears of the charging handle from the channel in the upper receiver through the relief slots.

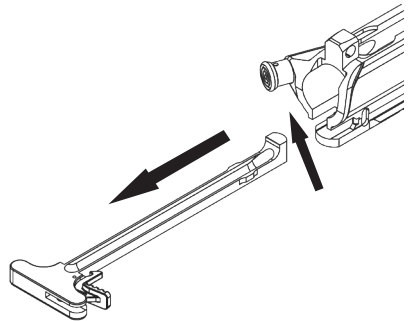

OPERATOR INSTRUCTIONS

UPPER RECEIVER DISASSEMBLY

BOLT AND CARRIER DISASSEMBLY

Removing the Bolt from the Carrier

- Remove firing pin retainer by pulling out on the small protrusion of the firing pin retainer away from the bolt carrier.

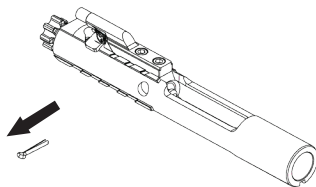

- Drop firing pin out of the rear of the carrier by inverting the carrier so that the bolt is upward, and lightly tapping the bottom of the carrier.

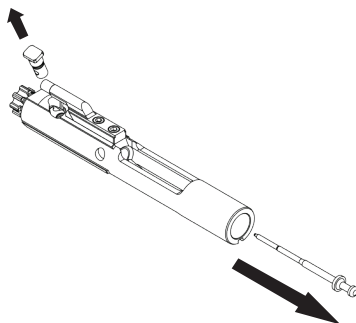

- Push bolt into the carrier and remove cam pin by rotating the cam pin 90 degrees and pulling away from the carrier. Ensure that the cam pin is aligned properly to fit past the gas key.

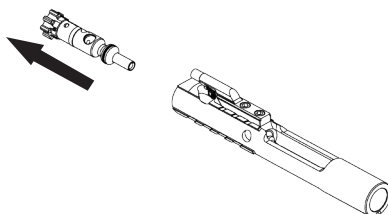

- Remove bolt from carrier by pulling forward, away from carrier.



OPERATOR INSTRUCTIONS



UPPER RECEIVER DISASSEMBLY

BOLT AND CARRIER DISASSEMBLY

 **NOTE:** The following steps are only necessary if the extractor is dirty or damaged. Be careful not to lose extractor spring (2 ea.). 

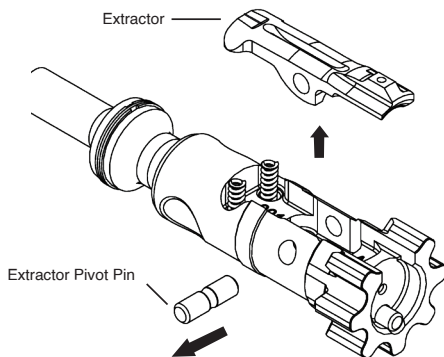
- Push extractor pivot pin out with appropriate sized punch.
- Remove extractor.



 **NOTE:** Ejector removal is an armorer level repair procedure. 

OPERATOR INSTRUCTIONS

UPPER RECEIVER ASSEMBLY

BOLT ASSEMBLY

- Place extractor into recess in bolt, hold extractor with the pivot pin holes in alignment.
- Squeeze the extractor toward the bolt body to fully align the pivot pin holes.
- Insert the pivot pin, tapered end first, as far as possible by hand.
- Use non-marring tool to fully seat the pin so that it is at equal depth on both sides of the bolt.

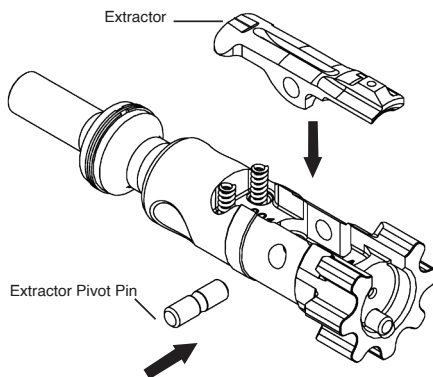

OPERATOR INSTRUCTIONS

UPPER RECEIVER ASSEMBLY

BOLT CARRIER GROUP ASSEMBLY

- Insert bolt into carrier mouth.
- Rotate bolt so that the cam pin hole is aligned with the cam path, clear of the gas key, with the ejector toward the left side of the bolt carrier, and the extractor toward the right side of the bolt carrier.

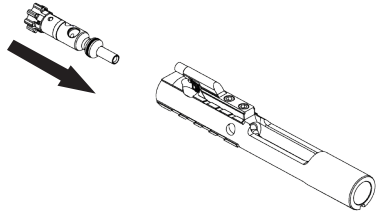

- Insert cam pin into the cam pin hole of the bolt, turned to clear the gas key. Rotate 90 degrees to ensure that the cam pin is in proper orientation to permit the firing pin to pass through the firing pin hole of the cam pin.

- Extend the bolt in the carrier to the “unlocked” position.

- Invert the bolt carrier so that the bolt is facing downward and the tail of the carrier is upward.

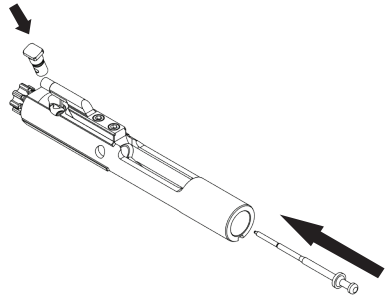

- Cover the hammer relief groove of the bolt carrier with a hand as the firing pin is dropped into the bolt carrier.

- Ensure that the firing pin falls fully forward and insert the firing pin retainer.

- Ensure that the firing pin is properly retained by orienting the bolt carrier so that the bolt is facing upward and the bolt carrier tail is downward, and firmly smacking the rear of the tail. If the firing pin drops free or is visibly not in correct position, reinstall the firing pin as per the above instructions.

Proper relationship of firing pin retaining pin and firing pin

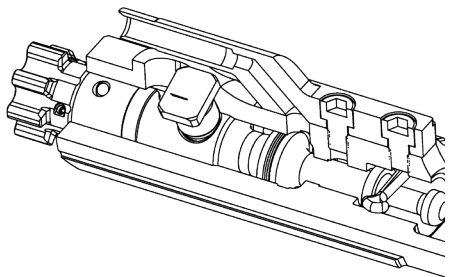

OPERATOR INSTRUCTIONS

UPPER RECEIVER ASSEMBLY

BOLT AND CARRIER ASSEMBLY

- With sights down, insert charging handle into upper receiver. Ensure charging handle lugs enter their grooves in the rear of upper receiver through the clearance slots near the rear of the upper receiver. Position the charging handle three inches from its fully forward position.

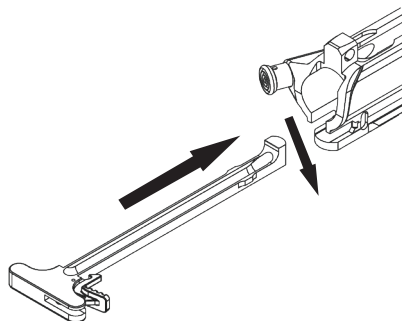

- Extend bolt in bolt carrier to the “unlocked” position.
- Insert bolt and carrier group carefully into upper receiver, aligning the gas key with the groove of the charging handle.

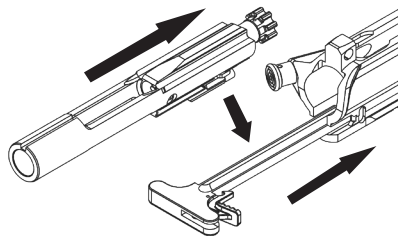

- Push forward on carrier until bolt and charging handle are fully forward. It may be necessary to lock the charging handle forward to fully seat the bolt carrier.
- Close dust cover.

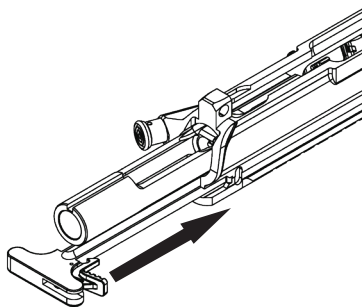

OPERATOR INSTRUCTIONS

LOWER RECEIVER DISASSEMBLY

BUFFER AND BUFFER SPRING DISASSEMBLY

- Ensure hammer is cocked.
- While slightly pressing rearward on buffer, with a non-marring tool, depress the buffer retaining pin and release buffer slowly.

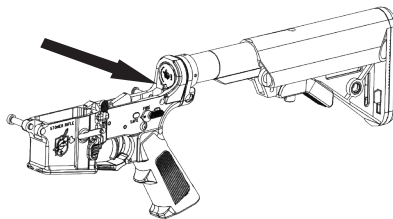

CAUTION
Buffer is under tension.



- Remove buffer and spring.

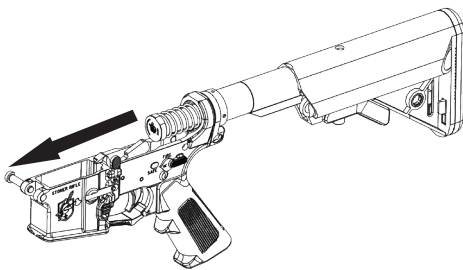

OPERATOR INSTRUCTIONS

LOWER RECEIVER ASSEMBLY

BUFFER AND BUFFER SPRING ASSEMBLY

- Ensure that the hammer is in the cocked position.
- Slide action spring into receiver extension (buffer tube).

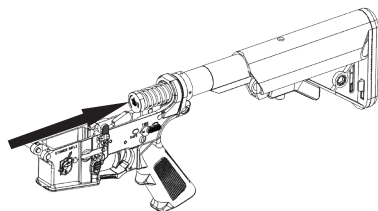

- Place tail of buffer into spring, ensuring that spring is fully captured against the head of the buffer, and compress spring and buffer past the buffer retaining pin to retain the buffer and spring.

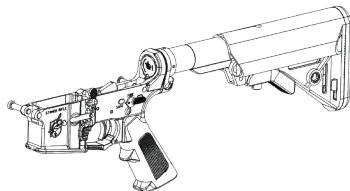

CAUTION
Buffer is under tension.



OPERATOR INSTRUCTIONS

RIFLE ASSEMBLY

- Ensure that the takedown pins of the lower receiver are fully retracted.
- Position upper receiver into the lower receiver with front and rear pins in alignment with pin holes.
- Press takedown pins into the seated position.
- Conduct function check as explained in the “Function Check” section on page 7-8.

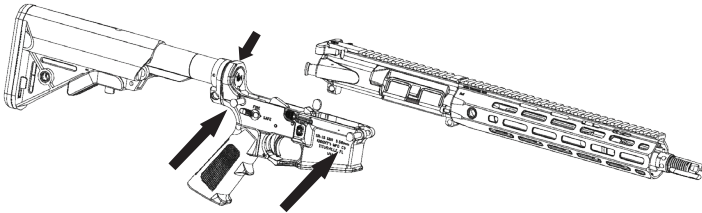

OPERATOR INSTRUCTIONS

MAGAZINE DISASSEMBLY

- Empty magazine carefully. Do not bend, deform, or gouge feed lips while emptying (stripping rounds from magazine).
- Turn magazine base plate up. Lift retainer clip on the baseplate sliding the baseplate to the rear. Cover the bottom of the magazine with the other hand in order to catch the spring and retainer plate as the baseplate is removed from magazine body. Note that the base is under spring tension.
- Jiggle spring while pulling it gently from magazine body to spring and follower assembly. Note magazine follower and spring are attached. Do not separate the follower from the spring if at all possible.

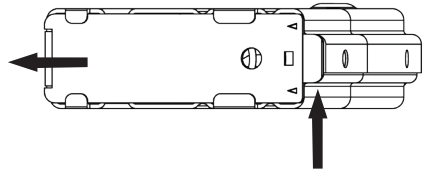

MAGAZINE REASSEMBLY

- Before reassembly, clean all foreign matter from magazine components. The magazine spring should be lightly lubricated with a cleaning patch wetted with only 2-3 drops of oil.
- Orient follower and spring to magazine body and carefully insert through bottom of magazine body. Jiggle spring while pushing gently until follower is seated under feed lips. Push the remainder of the spring into the magazine. Hold spring under tabs with thumb pressure.
- Orient baseplate so that the retainer clip is to the rear of the magazine and the retainer clip is angled up. Slide base under the tabs of the magazine body until the retainer clip positively engages magazine body.

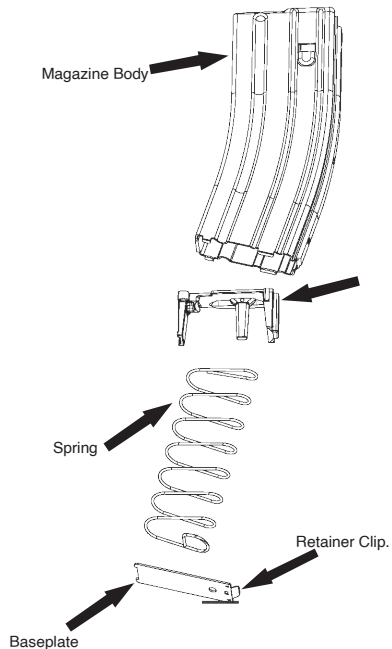

OPERATOR INSTRUCTIONS

CLEANING

- The exterior of the rifle may be cleaned off with water or a cleaner/lubricant and a soft bristled brush.
- After firing, clean your firearm as soon as possible before carbon hardens and corrosion begins.
- If you carry a loaded firearm, clean it at least once a month or more if necessary. If your firearm gets wet, clean it as soon as possible.
- Use only high quality cleaning components, exposure hazards, select the product that best matches operating environment and maintenance cycle.
- Ensure ample supply of bore patches and absorbent cleaning rags.
- Refer to the directions with the cleaning kit for guidance on proper use.

CHAMBER



NOTE: The chamber is the most important part of the barrel to be cleaned in order to ensure optimal precision and function.



- Thoroughly scrub chamber with bore cleaner or cleaner/lubricant, appropriate chamber brush, and handle. Insert the chamber brush fully into the chamber and scrub in a clockwise direction to prevent the brush from unscrewing.
- Use a general purpose brush and additional bore cleaner or cleaner/lubricant, with cleaning patch, or a rag, to clean residue from barrel extension locking lugs. Remove fouling behind the locking lugs, in the locking recess of the barrel extension, with cotton swabs, a rag, or other absorbent cleaning implement.
- If not able to immediately clean the bore, wipe the chamber and bore dry with a chamber mop and/or clean patches.

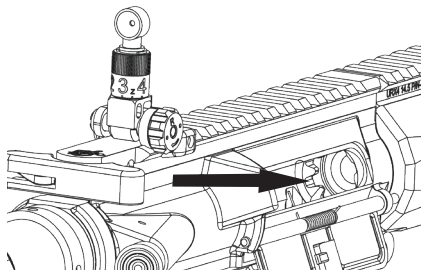

NOTE: The chamber is much larger in diameter than the bore; double-up the patches when wiping the chamber if not using a chamber mop. Two patches will usually fit a slotted bore rod tip when cleaning the chamber.



OPERATOR INSTRUCTIONS

BORE

- When cleaning the bore, keep muzzle pointed downwards and the sights orientated up to prevent bore cleaner from collecting in bolt locking recesses of the chamber area or seeping into the gas port.
- Always use a bore-rod guide to prevent damage to rifling. Insert bore guide through rear of upper receiver. Twist bore guide to engage into locking lugs. Align open port with ejection port. Unlock support cap by twisting counter-clockwise, and slide over bore rod. Once rod is inserted into bore guide, reconnect rear support to bore rod guide by twisting clock-wise until locked in place.
- Wrap an appropriately sized patch, wetted with bore cleaner or cleaner/lubricant around the brass jag and insert bore rod into the chamber.
- Push the patch through the receiver, into the chamber, and through the bore to clear the muzzle, and remove patch before withdrawing rod.
- Install a bore brush on the cleaning rod, push into the chamber, and through to clear the muzzle. Repeat several times as necessary to remove fouling from the bore.
- Do not reverse direction of the bore rod until the rod tip or bore brush has cleared the muzzle.
- Repeat this with another clean patch paying particular attention to wiping the chamber clear of old lubricant by rotating the rod clockwise, after the bore-rod guide is removed. If available, a chamber mop should be used to clean the chamber.
- If the bore is not adequately cleaned, repeat the process with both wet patches and bore-brush until a dry patch can be pushed through the bore with only minimal traces of fouling visible on the patch as it leaves the muzzle.
- Once the bore is clean, as a final step fouling accumulation, run a lightly lubricated patch through the bore, leaving a trace coating of oil.
- The muzzle device can be cleaned with a carbon remover or a cleaner/lubricant and a soft bristled brush and an absorbent cloth.
- DO NOT scrape the end of the muzzle with any sharp or metal instrument, as this may harm the crown of the barrel, resulting in decreased precision. Fouling can be softened by soaking with carbon remover or a cleaner/lubricant. Passing the bore brush through the bore will clear away carbon from the crown. If desired, a plastic or wooden tool may be used to remove additional buildup.

OPERATOR INSTRUCTIONS

CLEANING

BOLT CARRIER GROUP



NOTE: Disassemble in accordance with procedures on page 18 of this manual.



- Remove carbon/fouling from the exterior of the bolt carrier with cleaner/lubricant and a soft-bristled brush.
- Remove fouling from the cam-pin slot and expansion chamber with carbon remover or cleaner/lubricant and a soft bristled brush, absorbent cloth, or cotton swab.
- Use patches, cotton swabs, and/or an absorbent cloth to remove loose carbon/fouling after use of brushes.

LOWER RECEIVER

- Ensure the takedown and pivot pins are free of fouling or rust. Clean thoroughly with cleaner/lubricant and a soft bristled brush.
- Ensure the selector lever is clean and free of corrosion. Clean thoroughly with cleaner/lubricant and a soft bristled brush.
- Ensure the magazine well and magazine catch are clean and free of dust, sand, dirt, and fouling. Clean thoroughly with cleaner/lubricant, a soft bristled brush, and an absorbent cleaning cloth.
- Clean both the left and right side magazine releases with a cleaner/lubricant and a soft-bristled brush.
- Ensure the bolt catch and right-side bolt release are free of carbon fouling, dirt, and corrosion. Clean thoroughly with cleaner/lubricant and a soft bristled brush.
- The fire control group (trigger, hammer, and associated pins and springs) should not be removed except by an armorer. The parts should be cleaned in place with a cleaner/lubricant, soft bristled brush, and an absorbent cleaning cloth. Buildup inside the floor of the fire control group recess can be flushed out with hot water, pressurized air, or a pressurized firearm cleaning liquid.
- Wipe the buffer and action spring with an absorbent cloth and a cleaner/lubricant.
- Wipe the interior of the buffer tube with an absorbent cloth.

UPPER RECEIVER

- Wipe out the upper receiver with an absorbent cloth and cleaner/lubricant.
- Clean off the exposed portion of the gas tube inside the upper receiver with carbon remover or cleaner/lubricant and a soft bristled brush and absorbent cloth.
- Remove fouling, dirt, and corrosion from the ejection port cover with a soft bristled brush and absorbent cloth.
- Ensure the pivot and takedown pin holes in the upper receiver lugs are free of fouling.

OPERATOR INSTRUCTIONS

LUBRICATION

- Over-lubrication of the exterior of the rifle should be avoided at all times. A light to medium coat of lubricant on the operating parts and exposed metal parts of the exterior rifle is all that is required to prevent rust. The following lubricating instructions are for before operations and firing, not storage.
- **LIGHTLY LUBRICATED:** A thin film of oil barely visible to the eye. Wetting a cleaning patch with 5-10 drops of oil and then wiping the area over several times with the same patch should produce this effect and spread the oil thinly and evenly.
- **GENEROUSLY LUBRICATED:** A medium thick film of oil that can be spread or dabbed on with a finger. This can be applied with the fingers or a patch wetted with 20-30 drops of oil.
- **HEAVILY LUBRICATED:** A dripping wet application that allows a bead of lubricant to almost fall from the part. This can be applied by dripping the product directly onto the item.
- Remove any gun cleaning solution, oil, and fingerprints from the outside surfaces of the firearm.

UPPER RECEIVER

- Lightly lubricate the inside of the upper receiver with oiled patch, or absorbent cloth.
- Place one drop of oil on ejection port cover detent, then push detent in several times to work oil into spring.
- Place one drop of oil on each end of the ejection port cover hinge and rotate cover open and closed.
- Lightly lubricate the ejection port cover and spring.

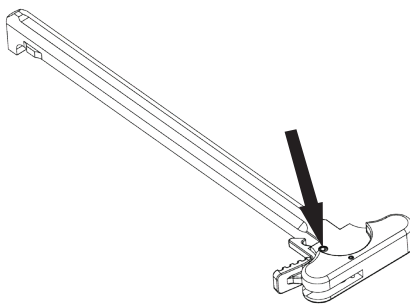

OPERATOR INSTRUCTIONS

LUBRICATION

BOLT AND CARRIER

- Heavily lubricate the bolt and gas rings.

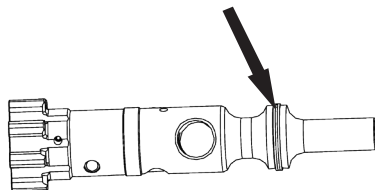

- Drip a single drop of cleaner/lubricant into the open end of the gas key.
- Generously lubricate inner and outer surfaces of bolt carrier.
- Generously lubricate the cam-pin groove.
- Generously lubricate the cam pin.
- Generously lubricate the carrier's hammer cocking surface and the four carrier slide ribs (located on either side of the gas key, two are located at 10 and 2 o'clock, and two are at 5 and 7 o'clock).

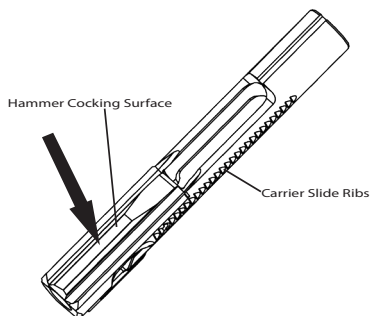
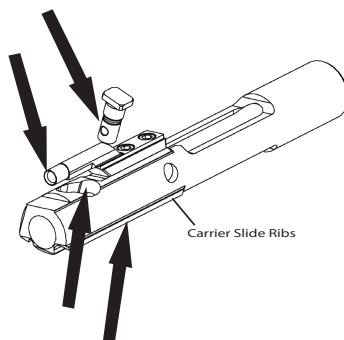

OPERATOR INSTRUCTIONS

LUBRICATION

BOLT AND CARRIER

- Lightly lubricate the extractor, extractor springs, and extractor pin.

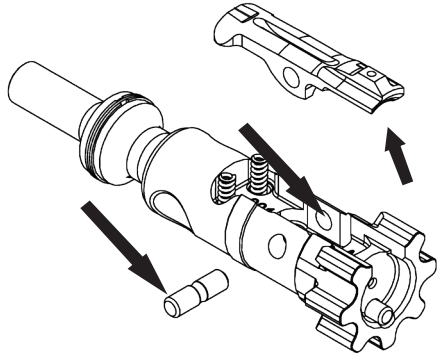

- Apply one drop of cleaner/lubricant to the area around the ejector. Tilt the bolt to allow cleaner/lubricant to flow to the ejectors. Use a plastic or brass tool of appropriate size to depress ejector with thumb pressure several times. Repeat until the cleaner/lubricant works past the ejector and spring action is strong.

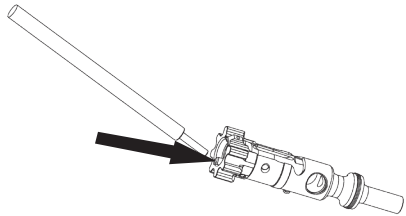

- Lightly lubricate the firing pin and firing pin recess hole.

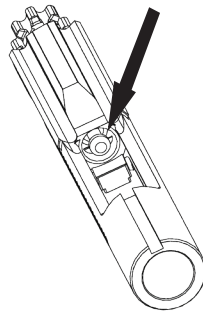

OPERATOR INSTRUCTIONS

LUBRICATION

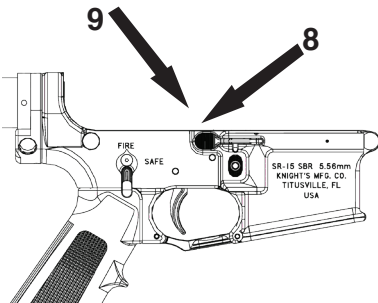
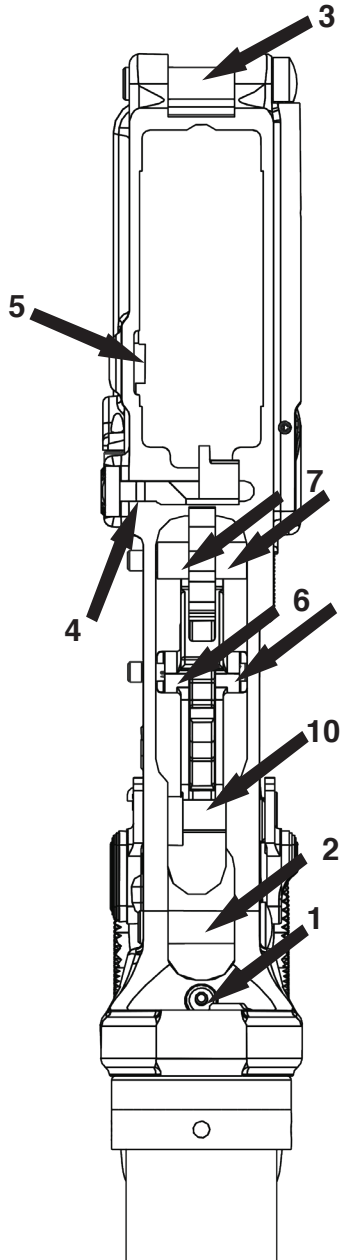

LOWER RECEIVER

- Place one drop of oil on buffer detent (1) and push detent in several times to work lubricant past detent to detent spring. Brush/wipe off excess oil.
- Generously lube take down and pivot pins. (2)(3) Apply one drop of oil to their detent grooves.
- Apply one drop of oil to the bolt catch, (4) trigger guard detent, magazine catch button, and magazine catch bar (5) areas. Work these controls in and out several times. Brush/wipe off any excess oil.
- Hold hammer down (to rear), apply one drop of oil to each end of the trigger pin (6). Pull trigger to rear several times to work oil between trigger pin and receiver.
- Apply one drop of oil to each end of the hammer pin (7). Rotate the hammer back about 1 inch several times while keeping the trigger pulled. Repeat this several times to work oil between hammer in and receiver.
- Rotate hammer back fully with trigger pulled and note action of disconnecter and rear hammer hook. Apply one small drop of oil each to contact surfaces of the hammer hook and disconnecter and in between the sear and the disconnecter.
- When the hammer is forward, the hammer's sear hooks can be observed within the lower receiver. Apply one small drop of oil to the front and rear hooks, (8) (9) and with finger off trigger, cock the hammer.
- From inside receiver, apply one drop of oil to both visible round ends of the safety selector lever shaft (10) and to the end on the right side of the receiver. Rotate safety from "FIRE" to "SAFE" several times. Wipe off excess oil.



OPERATOR INSTRUCTIONS

LUBRICATION LOWER RECEIVER

 **NOTE:** Control fall of hammer with thumb to prevent hammer from striking the receiver and bolt catch, as this may cause damage to the hammer, lower receiver, and/or bolt catch. 

- Generously lubricate the face of the hammer.
- Lightly lubricate buffer spring.
- Assemble lower and upper receivers. Check action of charging handle, bolt catch, and dust cover.

OPERATOR INSTRUCTIONS

PREVENTIVE MAINTENANCE CHECKS AND SERVICES (PMCS)

B=Before Operation D=During Operation A=After Operation

ITEM NO.	INTERVAL	PROCEDURE	EQUIPMENT IS NOT READY/AVAILABLE IF:
1	B,A	Check the system parts.	Major parts or components are missing.
2	B,A	Visually inspect the entire rifle for damaged or missing rifle components.	If components are damaged or missing.
3	A	Clean the rifle and accessories.	If rifle or components are dirty.
4	B,A	a. Actuate safety – rifle must be cocked. b. Rotate safety to "SAFE" position, squeeze trigger. c. Rotate safety to the "FIRE" position, squeeze trigger.	a. If hammer will not stay cocked. b. If hammer falls. c. If hammer does not fall forward.
5	B,A	BOLT OPERATION – grasp charging handle and pull bolt fully to the rear. Operation should be smooth.	If operation is not smooth.
6	B,A	BOLT CATCH – while holding bolt to the rear, depress lower end of bolt catch and return charging handle fully forward. Bolt should be retained to the rear by the bolt catch.	If bolt is not held to the rear by the bolt catch.
7	B,A	MAGAZINES – check spring action for free up and down movement of magazine follower. Movement should be smooth and strong.	If magazine follower movement is not smooth and strong.
8	B,A	FUNCTION CHECK. Perform function check as shown on page 8-9.	If rifle fails function check.

OPERATOR INSTRUCTIONS



NOTE: The KAC Drop-in trigger is capable of being placed on safe without having the hammer in the fully cocked position. This allows the user to relieve pressure on the hammer spring and also apply the safety. From fired position, slightly pull bolt to the rear while attempting to engage safety. After the bolt moves slightly out of battery the safety will engage without the hammer being cocked. The firearm will be in a locked condition and will not allow the bolt to move to the rear. To unlock, apply slight pressure rearward on charging handle and move the selector to fire. This will allow the bolt carrier to move and cock the hammer.



STOPPAGE REDUCTION

In the event of a stoppage apply the following actions:

- Ensure magazine is properly seated.
- Pull charging handle all the way to the rear. Observe ejection of empty case or complete round (if any). Visually check chamber for obstructions.
- If the chamber is clear, release charging handle to feed a new round into the chamber. Do not ride the charging handle allow it to spring forward under pressure from the compressed recoil spring.
- If the conditions permit, aim the rifle and attempt to fire again. If rifle again fails to fire; remove magazine, lock bolt to rear (ensuring that there is not a chamber obstruction), select a new magazine and reload.
- If rifle again does not fire, clear the rifle and apply the remedial actions below.

DOUBLE FEED/BOLT CARRIER JAMMED

Bent magazine lips can create a feeding malfunction where more than one round is stripped from the magazine. The only direction the carrier and bolt can move with a double feed is to the rear, but the charging handle may be impeded as well by the double feed. If this malfunction occurs, follow these steps:

- Move selector lever to SAFE, and remove magazine.
- Attempt to lock bolt to the rear using the bolt catch and charging handle. Return charging handle to the forward locked position.
- With bolt locked to the rear, clear loose rounds from interior of receiver.
- If the bolt cannot be locked to the rear using the charging handle, push bolt to the rear with a tool inserted forward of the bolt face, and lock to rear with bolt catch.
- Ensure that the obstruction is removed, reload with a new magazine if possible, chamber a round, and if the conditions support, attempt to fire.

OPERATOR INSTRUCTIONS

STOPPAGE REDUCTION

WARNING



If your rifle stops firing with a live round in the chamber of a hot barrel, point the rifle in a safe direction and remove the round as fast as you can. If it cannot be removed within 10 seconds, keep the rifle pointed in a safe direction with the bolt forward and fully locked, remove the magazine and wait 15 minutes for the chambered round to cool before initiating remedial action. These are precautions to prevent injury or death from a cook off. Keep all body parts away from the ejection port while clearing a hot chamber



- Remedial action is applied when the above steps have failed to correct the malfunction. Most likely an obstruction can be seen. If the new cartridge fails to chamber there may be a bore obstruction.
- Lock the bolt to the rear and clear these obstructions as follows:
- To clear a stuck cartridge case, tap it out with a cleaning rod inserted from the muzzle. Do not attach anything to the cleaning rod end for these procedures. If a complete cartridge is ejected, a faulty primer probably caused the malfunction. If so, check the primer:

If it has a normal firing pin indentation and the chamber and bore are clear of obstructions, reload with fresh ammunition and test fire rifle.

If primer is not indented sufficiently, check firing pin tip for a broken or flattened tip. See Failure to Fire in the Trouble Shooting Table.

WARNING



If an "audible pop" or reduced recoil is experienced during firing, immediately cease firing and clear the rifle. The "pop" could have been an incomplete powder burn which results in the bullet not leaving the bore. If another round is chambered and fired, the rifle will experience a severe over-pressure event, possibly causing injury or death.



- To clear a stuck bullet lodged in the rifling just outside the chamber; tap it out gently using the cleaning rod as for a stuck cartridge case described previously. Be careful not to damage the crown end of the muzzle during these procedures. A bullet stuck in the bore is caused by a round without any, too little, or contaminated powder. Although a very rare circumstance, it can have disastrous effects. See WARNING above.
- If gentle tapping on the cleaning rod will not dislodge the stuck bullet, seek an Armorer's assistance.

OPERATOR INSTRUCTIONS

TROUBLESHOOTING



NOTE: These are some conditions that may be observed, but they are not all inclusive.



MALFUNCTION	CAUSE	CORRECTION/ACTION
1. Failure to Fire	<ul style="list-style-type: none"> a. Safety on "SAFE". b. Defective ammunition. c. Improper assembly of firing pin. d. Short firing pin protrusion. e. Round not fully chambered. f. Hammer not cocking, or "hair trigger". g. Trigger fails to release hammer. h. Rifle (pistol) grip screw is too long or washer is missing. 	<ul style="list-style-type: none"> a. Move safety to "FIRE". b. Eject round, chamber new round. c. Ensure retaining pin passes behind large diameter of firing pin. d. Replace firing pin. e. Clear obstruction from chamber. Clean and lube bolt, cam pin and carrier. f. Clean chamber and ensure any obstructions are cleared. Lubricate bolt and bolt carrier. g. Contact armorer or KAC customer service at 321-607-9900. h. Loosen rifle grip screw and re-test hammer cocking and trigger pull. Install correct parts.
2. Failure to Unlock	<ul style="list-style-type: none"> a. Gas key clogged. b. Gas port or tube obstructed. 	<ul style="list-style-type: none"> a. Use pipe cleaner to check/clear gas key. b. Contact KAC customer service at 321-607-9900.
3. Failure to Extract	<ul style="list-style-type: none"> a. Chamber or ammo dirty. b. Extractor spring worn. c. Extractor fouled. 	<ul style="list-style-type: none"> a. Clean chamber and wipe ammunition clean. b. Replace springs. c. Remove, clean and lube extractor.
4. Failure to Eject	<ul style="list-style-type: none"> a. Frozen ejector. b. Insufficient gas pressure. c. Restricted movement of bolt carrier group. d. Restricted buffer. 	<ul style="list-style-type: none"> a. Clean and lubricate ejector. b. Replace gas rings. Clean gas key. Replace ammunition. c. Remove, clean, lube. Check gas key fit and gas tube. d. Remove, clean and lubricate.
5. Failure to Cock	<ul style="list-style-type: none"> a. Disconnecter hook worn. b. Disconnecter spring weak. c. Hammer hook worn. d. Hammer spring broken. 	<ul style="list-style-type: none"> Have fire control group replaced by armorer or contact KAC Customer Support at 321-607-9900.
6. Failure to Feed	<ul style="list-style-type: none"> a. Dirty/corroded ammunition. b. Magazine not fully seated. c. Double feed. d. Bolt overrides cartridge. e. Restricted movement of bolt carrier group. f. Restricted buffer. g. Excessive rounds in magazine. h. Dirty magazine. 	<ul style="list-style-type: none"> a. Clean or replace. b. Adjust magazine catch. c. Replace magazine. d. Replace magazine. e. Remove, clean, lube. f. Remove, clean, lube. g. Remove excess. h. Disassemble, clean, and lubricate magazine body and magazine spring.
7. Failure to Chamber	<ul style="list-style-type: none"> a. Obstruction in chamber. b. Dirty/corroded ammo. c. Bullet stuck in bore just past chamber. 	<ul style="list-style-type: none"> a. Clear chamber. b. Replace ammo. c. Contact KAC customer service at 321-607-9900.
8. Failure to Lock	<ul style="list-style-type: none"> a. Dirty bolt/locking lugs. b. Dry/dirty cam pin or cam pin groove. c. Burrs on bolt locking lugs 	<ul style="list-style-type: none"> a. Remove, clean, lube. b. Remove, clean, lube. c. Show to armorer.

DISCLAIMER

KAC shall not be held responsible for injury, death, or damage to property resulting from either intentional or accidental discharge of a firearm, or from its function when used for purposes or subjected to treatment for which it was not designed.

KAC will not honor claims involving a firearm which result from careless or improper handling, unauthorized adjustment or parts replacement, corrosion, neglect, the use of incorrect caliber ammunition, or the use of ammunition other than original high quality commercially manufactured ammunition in good condition, or any combination thereof.

KAC cannot control product handling after it leaves the factory. Examine this item carefully at the time of delivery to ensure that it is undamaged.

This instruction manual should always accompany this item. When you lend, give, or transfer this item, ensure that a copy of this manual is with it.

WARRANTY STATEMENT

KNIGHT'S ARMAMENT COMPANY & KAC / KMC LIMITED WARRANTY

Knight's Armament Company has a high standard of quality for its products and stands behind them. Knight's products will be serviced for a period as specified in the purchase agreement from the date of delivery for defects in materials or workmanship at no charge to the original purchaser. Damage deemed to be the result of abuse and/or the lack of owner/operator maintenance is not covered by this warranty. Be sure to use official channels when submitting a claim.

Products and firearms are warranted to be free from defects in material and workmanship. This warranty shall apply to the original owner for a period of 1 year from date of purchase or delivery. Any such defects of which KAC / KMC receives written notice within 1 year from the date of purchase by the original owner, will be remedied by KAC / KMC without charge.

Warranty claims must be submitted to Knight's Armament's Customer Service department in writing, via the RMA process outlined below. The information should contain the owner's name, phone number, shipping / billing address, serial number (if applicable), and details regarding the issue. Additional information, such as photos or videos, may be requested by KAC to help determine the extent of the issue.

****CUSTOMER IS RESPONSIBLE FOR SHIPPING CHARGES TO KAC / KMC UNLESS THERE WAS A SHIPPING ERROR MADE BY KAC / KMC****

Warranty Repair:

Includes all labor, parts, and return shipping charges required to remedy the issue as outlined in the Limited Warranty statement. This does not cover claims for:

- Misuse, abuse, or lack of compliance to the owner's manual
- Improper installation of KAC or aftermarket accessories
- Normal wear and tear
- Rust or corrosion due to lack of compliance with proper cleaning procedures
- Obstructions in barrel
- Use of defective or improper ammunition

****KAC / KMC reserves the right to determine what constitutes unreasonable or excessive use****

ANY UNAUTHORIZED ALTERATION OR MODIFICATION OF THE FIREARM, OR USE OF PARTS OR COMPONENTS NOT ORIGINALLY INCORPORATED BY KAC SHALL VOID THIS WARRANTY.

NON – WARRANTY REPAIR:

Once an item is received, via the RMA process, a technician will inspect the item and prepare a written estimate that outlines the work to be performed and estimated prices. In order to proceed with the repair, the estimate must be acknowledged by the customer in writing and paid for in advance. If the customer does not wish to proceed, the item will be returned at the customer's expense.

Return / Exchange Policy:

Items may be returned within 90 days of purchase for refund or exchange for a different product. Any cost differences in exchanges and shipping charges will be at the customer's expense. The customer shall be responsible for return freight and a 15% restocking fee for all returns unless an error was made by KAC / KMC.

Original purchase receipt is required for all returns and exchanges. All items must be in new condition and include all accessories and packaging or additional fees may apply. Apparel must be in new, unwashed condition to be considered for return or exchange. If an item is deemed defective, please see the warranty policy.

This return / exchange policy only applies to purchases made directly from KAC / KMC. If an item was purchased from a distributor or dealer, please contact them for their return policy.

Items not covered under the Return / Exchange Policy:

- Weapons
- Suppressors
- Knight Vision
- Labor
- Ammunition
- Damaged or used items

RMA PROCEDURE:

Contact KAC / KMC Customer Service Department in writing at returnsandrepairs@knightarmco.com. Please include your name, telephone number, and a description of the issue you are experiencing. Be as detailed as possible, as any field related repairs will be exhausted before requesting a possibly defective item back for repairs. Please be aware any item sent back without following these procedures, or without a RMA number, will be handled after any other proper returns ahead of it. Returns, once assigned an RMA number, may be returned to:

Knight's Armament Company

Attn: RMA XXXXX

701 Columbia Blvd.

Titusville, FL 32780

Standard turnaround time for all returns is within 10 business days. Please be aware this time frame may change due to Military or Government orders. Any general questions should be directed to: info@knightarmco.com

ADDENDUM

BACK-UP IRON SIGHTS

The back-up iron sights are designed to provide the user with an in-extremis redundant aiming system. The BUIS can be employed to successfully engage point targets from 0 to 600 meters.

FRONT SIGHT INSTALLATION AND REMOVAL

The front sight attaches to the handguard by means of a MIL-STD-1913 attachment system with a cross-bolt clamp. For retention of zero and return to zero, these steps must be strictly adhered to:

- Ensure that the sight base and upper receiver rail are clean and free of any corrosion, dust, liquid, or built-up paint.
- Loosen the attachment screw.
- Rock the sight base onto the mounting rail, using the forward-most available rail section.
- Ensure that the sight base sits flush with the top rail of the receiver. If the clamp prevents fully seating the mount, loosen the screw until the clamp clears the rail.
- Tighten the mounting clamp screw while pressing the sight base forward so that the mounting screw contacts the forward recoil lug. Tighten just until lightly hand snug.
- Complete mounting by tightening to 20 in/lbs. If a calibrated torque wrench is not available, this can be achieved by tightening the clamp screw $\frac{1}{4}$ turn past initial hand snugness.
- To remove: Loosen the clamp screw enough to allow the sight base to be lifted off of the receiver rail and lift sight off of the top receiver rail.

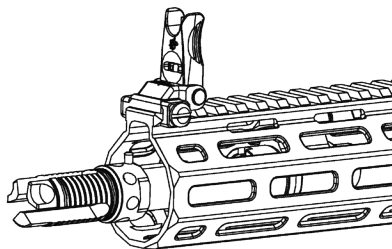
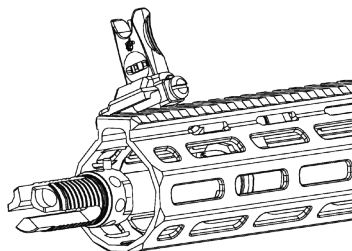

ADDENDUM

REAR SIGHT INSTALLATION AND REMOVAL

The front sight attaches to the handguard by means of a MIL-STD-1913 attachment system with a cross-bolt clamp. For retention of zero and return to zero, these steps must be strictly adhered to:

- Ensure that the sight base and upper receiver rail are clean and free of any corrosion, dust, liquid, or built-up paint.
- Loosen the attachment screw.
- Rock the sight base onto the mounting rail, using the rear-most available rail section.
- Ensure that the sight base sits flush with the top rail of the receiver. If the clamp prevents fully seating the mount, loosen the screw until the clamp clears the rail.
- Tighten the mounting clamp screw while pressing the sight base forward so that the mounting screw contacts the forward recoil lug. Tighten just until lightly hand snug.
- Complete mounting by tightening to 20in/lbs. If a calibrated torque wrench is not available, this can be achieved by tightening the clamp screw $\frac{1}{4}$ turn past initial hand snugness.
- To remove: Loosen the clamp screw enough to allow the sight base to be lifted off of the receiver rail and lift sight off of the top receiver rail.

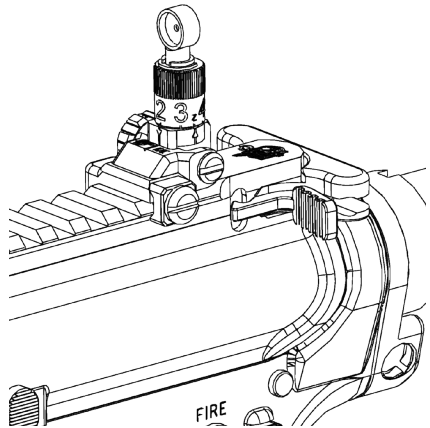
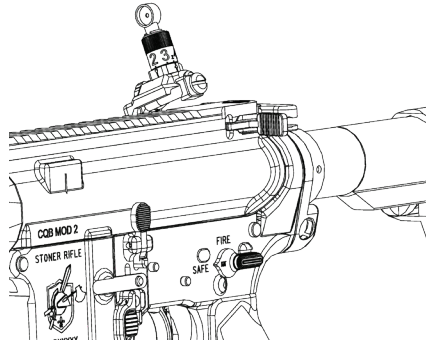

ADDENDUM

BACK-UP IRON SIGHTS

ZEROING:

To ensure the greatest accuracy in range compensation afforded by the sights, adhere to the following instructions for zeroing the offset sights:

1 Mount and torque the sights as per the "Installation" directions above, and deploy both the front and rear sights to the full upright position.

2 Set the rear sight to "2".

3 Conduct a boresight for initial sight settings.

a. If a laser boresight is available, follow the directions as indicated for iron sights.

b. If a laser boresight is not available:

- i. Position a target 50 meters from the shooting position.
- ii. Ensure that the firearm is clear, with no ammunition present.
- iii. Remove the upper receiver from the lower receiver and remove the bolt carrier group from the upper receiver.
- iv. With the sights in the deployed position and oriented upward, align the bore of the upper receiver with the target at 50 meters, maintaining that position with a solid rest, by looking through the rear of the upper receiver/chamber area, through the bore.
- v. Make adjustments to the sights so that they coincide with the alignment of the bore. Remember that the sight adjustments will be reversed as indicated, as the sights themselves are being repositioned, not the Point of Impact as during firing.
- vi. Reassemble the upper receiver and attach it to the lower receiver, ensuring that the rifle is prepared for live-fire.

c. Ensure that the laser boresight is removed if used, and that the bore is free of any obstructions.

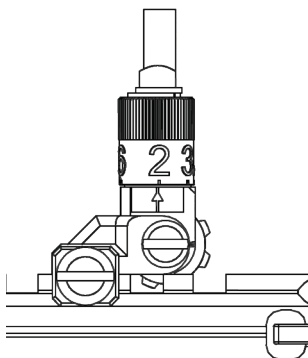

ADDENDUM

BACK-UP IRON SIGHTS

ZEROING:

4 Utilizing the deployed sights fire a 5-round group on a zeroing target at 50 meters.

5 Make bold sight adjustments utilizing the front sight for elevation correction, and the rear sight for deflection correction, based off of the center of the impact group.

a. Mark group and record adjustments.

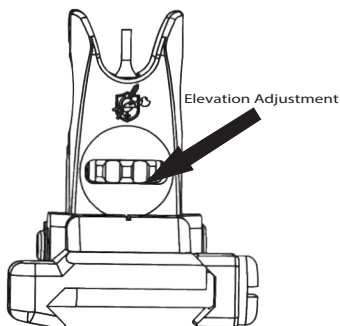

6 If possible, conduct final zeroing at 200 meters to bring the point of impact to the point of aim.

a. Use not less than 5-shot groups.

b. Ensure that wind effect is noted and removed from the sight settings prior to recording zero.

c. Note number of clicks from the limits of the adjustment range for reference in case the sight needs to be returned to the "Zero" position.

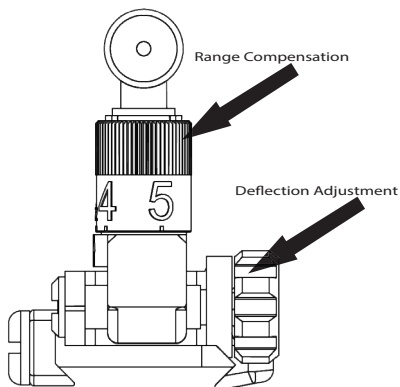

ADDENDUM

BACK-UP IRON SIGHTS

ZEROING:

- From the zeroed position, turn the windage knob on the rear sight fully to one direction, counting the number of clicks until the knob stops. Record that number. Reapply that number of clicks to bring the rear sight back to the correct windage zero and record the direction of travel and the number of clicks.

EX: User turns the knob until the rear sight base stops against the right side of the base, counting 21 clicks. The user then turns the knob in the LEFT direction 21 clicks, and records "21 LEFT".

- From the zeroed position, turn the front sight elevation wheel in the "UP" direction, counting the number of clicks until it stops. Reapply the number of clicks in the opposite (down) direction, and record.

EX: User turns the wheel until the front sight bottoms out, counting 15 clicks. The user then turns the wheel in the "down" direction 15 clicks, and records "15 DOWN".

- 7 As soon as possible, conduct confirmation at 300, 400, 500, and 600 meters, with the rear sight elevation drum initially turned to the corresponding "3", "4", "5", and "6" settings.

- a. If impacts are higher or lower than expected, make fine adjustments at the rear sight and record.

EX: While shooting at 500 meters, impacts are below point of aim. Shooter turns the range drum 2 clicks past "5", toward "6", and achieves point of aim impacts. Shooter records: "500 meters= 5+2".

- b. Past 200 meters, wind will be a significant factor in precision engagements. If wind effect corrections are applied to the sights, ensure that those adjustments are removed from the sight, returning the sight to the deflection "Zero" position as soon as firing is completed, or before commencing fire with a different wind condition.

- c. If range compensation requires excessive fine adjustment, adjust the front sight with the rear sight set on the correct range indication. Excessive adjustment is $\frac{1}{2}$ or more of the available adjustment between the desired and next range indicator. The optimal distance to properly balance the range drum for drop is 300 meters.

- 8 Turn the rear sight range drum to the most likely distance at which the back-up sights will be employed. The recommended rear sight setting is "2", as it will permit a trained user to successfully engage point targets from 0 to 250 meters with minimal requirement for hold-under or hold-over.

ADDENDUM

BACK-UP IRON SIGHTS

Field Expedient Zeroing:

If a 50 meter range is not available, an abbreviated zeroing may be conducted at 25 meters.

- 1 Follow the directions for laser boresighting or the directions above for boresighting without a laser.
- 2 Position a target 25 meters from the firing position.
 - Ensure that the laser boresight is removed if used, and that the bore is free of any obstructions.
- 3 Set the rear sight range drum to "Z".
- 4 Utilizing the deployed sights, fire a 5-round group on the target at 25 meters.
- 5 Make bold sight adjustments utilizing the front sight for elevation correction, and the rear sight for deflection correction, based off of the center of the impact group.
- 6 Mark group and record adjustments.
- 7 Continue firing 5-round groups, adjusting after each group to move the shot group to the point of aim at 25 meters.
- 8 Follow the directions above for establishing and recording the zero position.
- 9 Turn the rear sight range drum to the most likely distance at which the back-up sights will be employed. The recommended rear sight setting is "2", as it will permit a trained user to successfully engage point targets from 0 to 250 meters with minimal requirement for hold-under or hold-over.
- 10 Confirm and fine-adjust the zero at actual distance as soon as permissible, as per the instructions for zeroing.

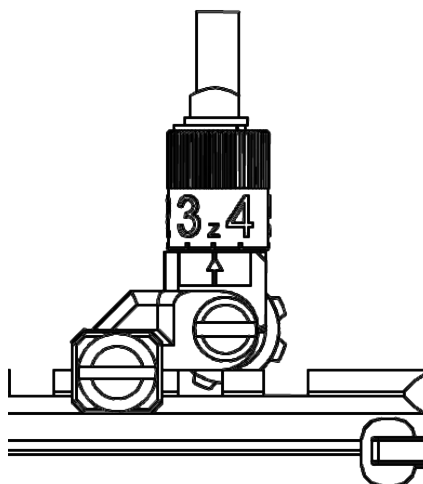

ADDENDUM

M-LOK PARTS INSTALLATION M-LOK ACCESSORIES

Adjusting The Nut To The Correct Height

- For best function, the T-Nut “gap” must be slightly greater than the thickness of the mounting surface (see pic). This can be done by measuring the mounting surface thickness directly or using the edge of the mounting surface as a gauge. For most aluminum mounting surfaces setting the nuts as depicted below, with the highest edge of the T-Nut even with the bottom edge of the recoil lug, will provide correct function. Some thicker rails or polymer rails may require the nuts to be looser with a one or two thread gap between the nuts and recoil lugs.

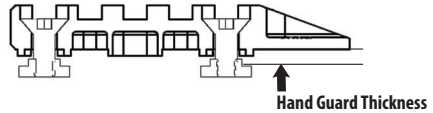

If the T-nuts are not rotating properly:

- When nuts are spaced too far then the nut will rotate freely without stopping and tightening.
- In this case the nut will have to be screwed in closer to the bottom of the accessory. Simply remove the accessory from the slot and screw the nut on one full turn. Repeat as necessary so that the cam engages the slot when the screw is tightened.
- If the nut is spaced too close to the accessory, then the “wings” of the nut will contact the sides of the slot and the nut will not rotate into place. This will cause the nut to tighten against the accessory lugs without engaging the hand guard.
- In this case the nut should be unscrewed until it is spaced far enough away from the lugs to allow it to rotate properly into position. Unscrew the nut one turn at a time and retest function.

ADDENDUM

M-LOK ACCESSORIES M-LOK PARTS INSTALLATION

Ensure that the accessory is fully seated into a slot when mounted.

- 1 The bottom of the accessory should sit flush with the mounting surface. If it does not then slide the accessory fore-aft until it drops fully into the slot with the lugs engaged.



Turn the attachment Screws.

- 2 Apply some downward force on the hex wrench to make sure that the screw is seated, and then tighten. For maximum repeatability, "bias" the accessory before fully tightening.

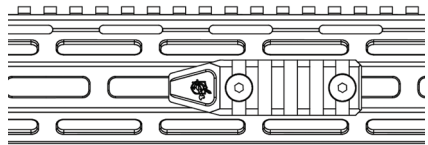

**Push down and
forward to bias** →

- 3 To bias the accessory, apply just enough lateral pressure to accessory to make solid contact with one side and the front (towards muzzle) of the slot, similar to when installing a Pictinny rail accessory. Then tighten all fasteners fully. This step aids repeatability.

Ensure that the nut rotates the full 90° into the locked position

- 1 If you have adjusted the nuts appropriately, they should rotate into perfect 90 degree alignment with a 1/4 turn of the screw.

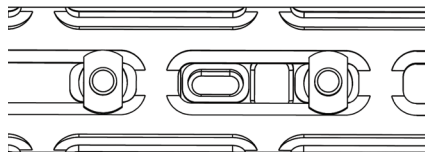
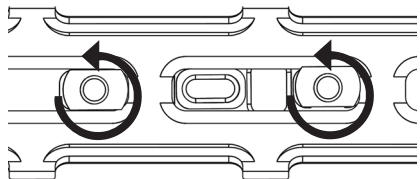

ADDENDUM

M-LOK ACCESSORIES M-LOK PARTS INSTALLATION

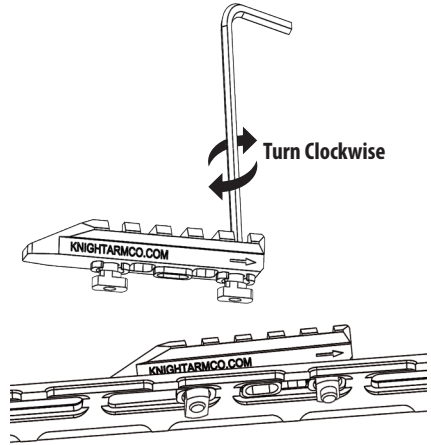

Intermediate Spacing Options

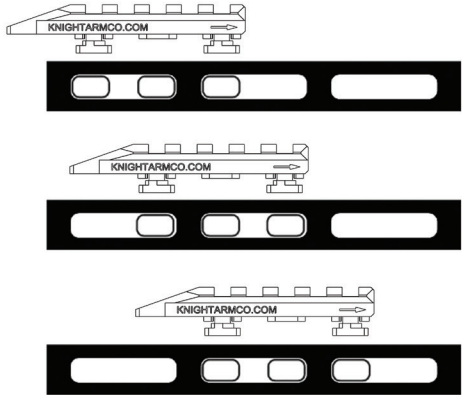

ADDENDUM

M-LOK ACCESSORIES

TORQUE SPECS AND REMOVAL

Torque Specs

- For attaching metal accessories to metal hand guards: 35 in/lbs
- For attaching polymer or metal accessories to polymer hand guards: 15 in/lbs
- The installation torque values are not minimums, they are recommended limits.
- The nylon patch compound may slightly affect the torque reading if using an in/lb torque wrench.
- Using a small hex wrench should prevent over-tightening. Remember that the recoil lugs are doing most of the work, and excessive torque on the nuts is not required.

IF YOU DO NOT HAVE AN IN/LB TORQUE WRENCH, HERE ARE SOME TORQUE GUIDELINES:

35 in-lb using the long arm of an L-wrench (short end in screw)

- Standard 2-5/16" wrench
 - Apply 15 lb to the end of the wrench
 - Approximately 1/4" deflection at the end of the wrench
- Long 3-13/32" wrench
 - Apply 9 lb to the end of the wrench
 - Approximately 1/2" deflection and the end of the wrench

15 in-lb using the long arm of an L-wrench (short end in screw)

- Standard 2-5/16" wrench
 - Apply 6.5 lb to the end of the wrench
 - Approximately 3/16" deflection at the end of the wrench
- Long 3-13/32" wrench
 - Apply 4 lb to the end of the wrench
 - Approximately 1/4" deflection and the end of the wrench

15 in-lb using the short arm of an L-wrench (long end in screw)

- Apply maximum force achievable by hand

Removal

- To remove, simply loosen the accessory mounting screws one full turn and the T-Nuts should loosen and align with the slot to be easily removed.
- If the T-Nuts snag when passing through the slot, simply pull up gently on the accessory and continue to loosen the screw another ¼ to ½ turn, which should align the T-Nuts with the slot.
- On some polymer mounting surfaces, the T-Nuts may embed slightly into the polymer surface when tightened.
- When removing from polymer surfaces, easiest function is obtained by loosening ½ turn or so and then pressing down on the head of the screw with the hex wrench. This will free the T-Nut if it has been over tightened, and you may remove normally after this step.
- If you go too far in loosening before removing the accessory, the T-Nuts may have loosened past the slot to the point that they will not engage and are spinning freely. In this case, gently pull up on the accessory until the T-Nut cams engage the slot, and then they will turn to align with the slot as the screw is loosened further.

SR-15 E3 MOD 2 UPPER RECEIVER ASSEMBLY

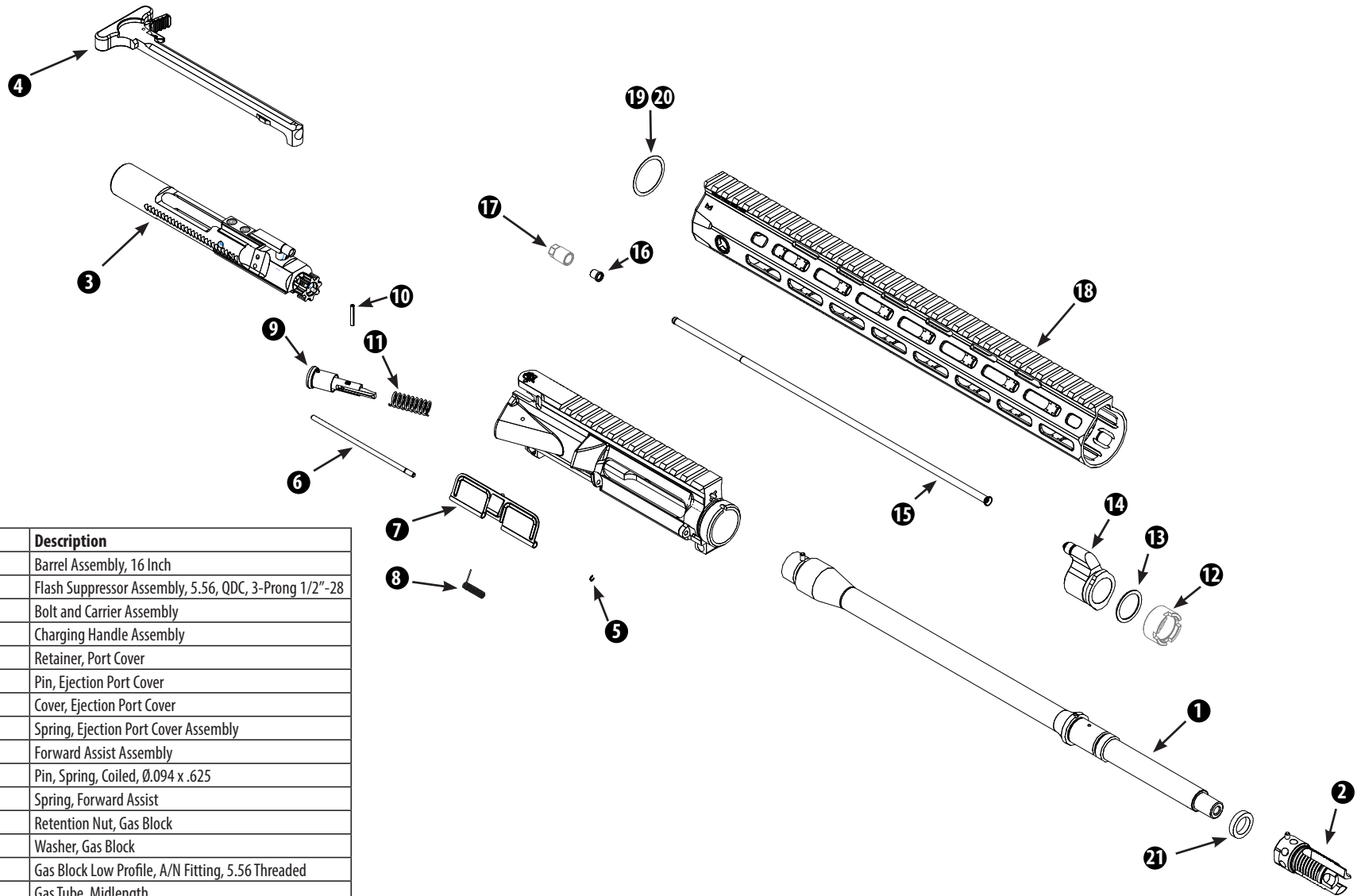

Item #	Part #	Description
1	30961	Barrel Assembly, 16 Inch
2	30495	Flash Suppressor Assembly, 5.56, QDC, 3-Prong 1/2"-28
3	99311-1	Bolt and Carrier Assembly
4	25897	Charging Handle Assembly
5	21513	Retainer, Port Cover
6	21133	Pin, Ejection Port Cover
7	22351	Cover, Ejection Port Cover
8	94049	Spring, Ejection Port Cover Assembly
9	30937	Forward Assist Assembly
10	22102	Pin, Spring, Coiled, Ø.094 x .625
11	21152	Spring, Forward Assist
12	30674	Retention Nut, Gas Block
13	30675	Washer, Gas Block
14	30886	Gas Block Low Profile, A/N Fitting, 5.56 Threaded
15	30580-1	Gas Tube, Midlength
16	30582	Sleeve, Gas Tube
17	30581	Nut, Gas Tube
18	31885-1450	Forend Assembly, 5.56 L14.5, URX IBN, M-LOK
18	30902-1	Forend Assembly, 5.56 L14.5, URX IBN, Keymod
19	31062-010-BLK	Shim, .010 Thick, Black
20	30299	Shim Set, 5.56 URX IBN (as required)
21	96051	Shim Set, Seven Piece, 5.56 (as required)

SR-15 E3 MOD 2 CARBINE UPPER RECEIVER ASSEMBLY

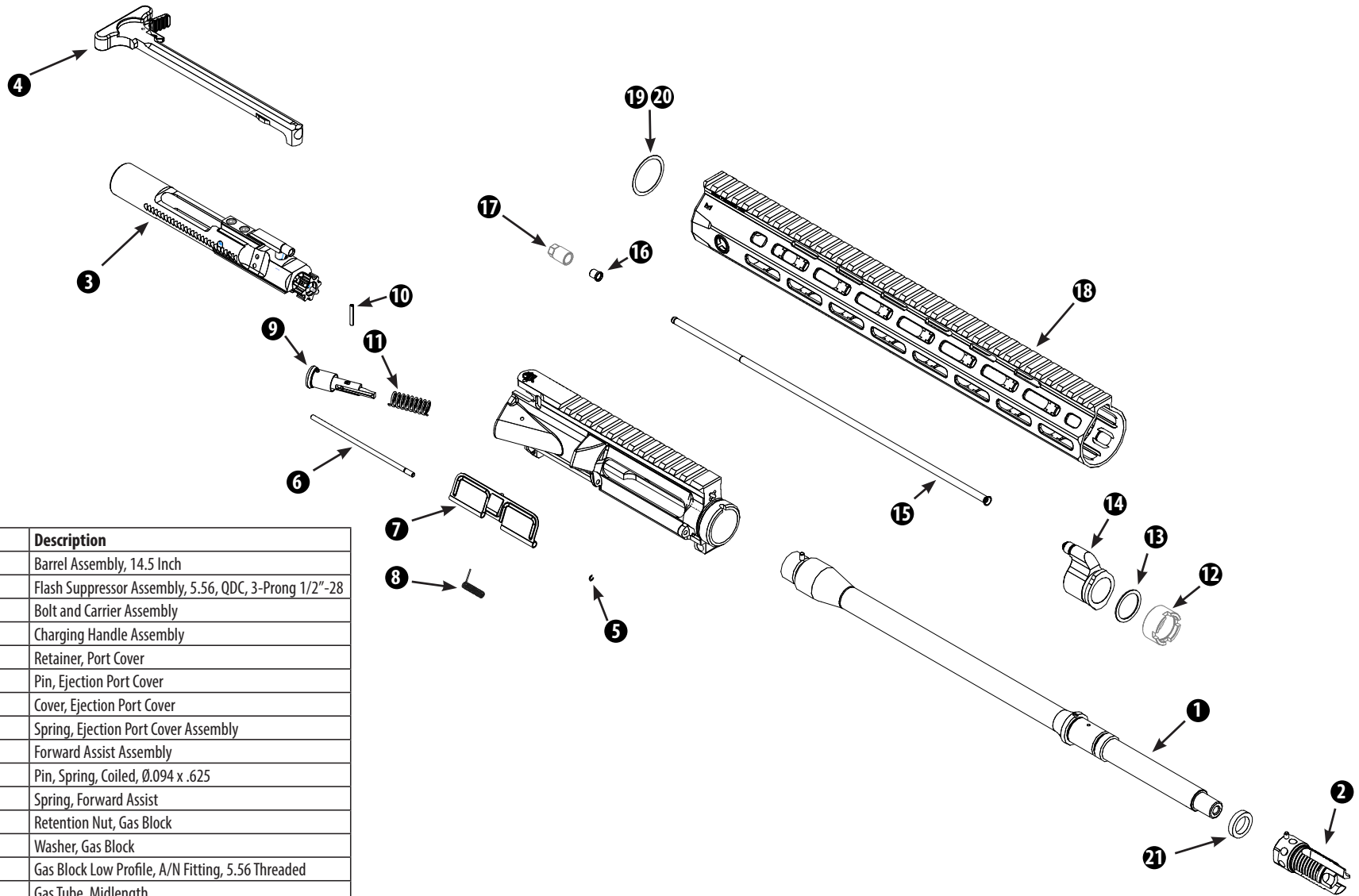

Item #	Part #	Description
1	30969	Barrel Assembly, 14.5 Inch
2	30495	Flash Suppressor Assembly, 5.56, QDC, 3-Prong 1/2"-28
3	99311-1	Bolt and Carrier Assembly
4	25897	Charging Handle Assembly
5	21513	Retainer, Port Cover
6	21133	Pin, Ejection Port Cover
7	22351	Cover, Ejection Port Cover
8	94049	Spring, Ejection Port Cover Assembly
9	30937	Forward Assist Assembly
10	22102	Pin, Spring, Coiled, Ø.094 x .625
11	21152	Spring, Forward Assist
12	30674	Retention Nut, Gas Block
13	30675	Washer, Gas Block
14	30886	Gas Block Low Profile, A/N Fitting, 5.56 Threaded
15	30580-1	Gas Tube, Midlength
16	30582	Sleeve, Gas Tube
17	30581	Nut, Gas Tube
18	31885-1300	Forend Assembly, 5.56 L13, URX IBN, M-LOK
18	30903-1	Forend Assembly, 5.56 L13, URX IBN, Keymod
19	31062-010-BLK	Shim, .010 Thick, Black
20	30299	Shim Set, 5.56 URX IBN (as required)
21	96051	Shim Set, Seven Piece, 5.56 (as required)

SR-15 E3 MOD 2 CQB UPPER RECEIVER ASSEMBLY

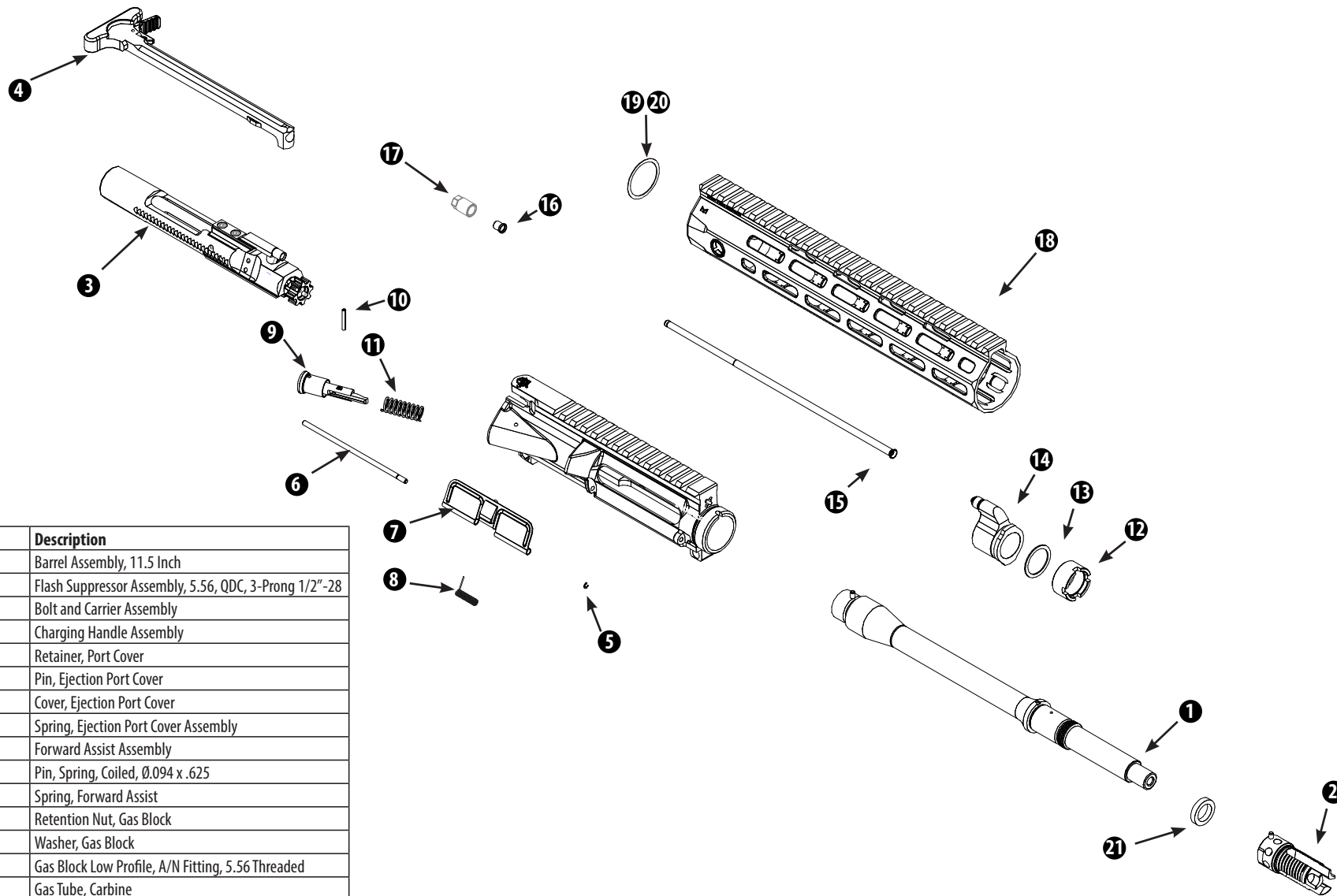

Item #	Part #	Description
1	30969	Barrel Assembly, 11.5 Inch
2	30495	Flash Suppressor Assembly, 5.56, QDC, 3-Prong 1/2"-28
3	99311-1	Bolt and Carrier Assembly
4	25897	Charging Handle Assembly
5	21513	Retainer, Port Cover
6	21133	Pin, Ejection Port Cover
7	22351	Cover, Ejection Port Cover
8	94049	Spring, Ejection Port Cover Assembly
9	30937	Forward Assist Assembly
10	22102	Pin, Spring, Coiled, Ø.094 x .625
11	21152	Spring, Forward Assist
12	30674	Retention Nut, Gas Block
13	30675	Washer, Gas Block
14	30886	Gas Block Low Profile, A/N Fitting, 5.56 Threaded
15	30580-2	Gas Tube, Carbine
16	30582	Sleeve, Gas Tube
17	30581	Nut, Gas Tube
18	31885-1075	Forend Assembly, 5.56 L10.75, URX IBN, M-LOK
18	31206-1	Forend Assembly, 5.56 L10.75, URX IBN, Keymod
19	31062-010-BLK	Shim, .010 Thick, Black
20	30299	Shim Set, 5.56 URX IBN (as required)
21	96051	Shim Set, Seven Piece, 5.56 (as required)

SR-15 E3 MOD 2 LPR UPPER RECEIVER ASSEMBLY

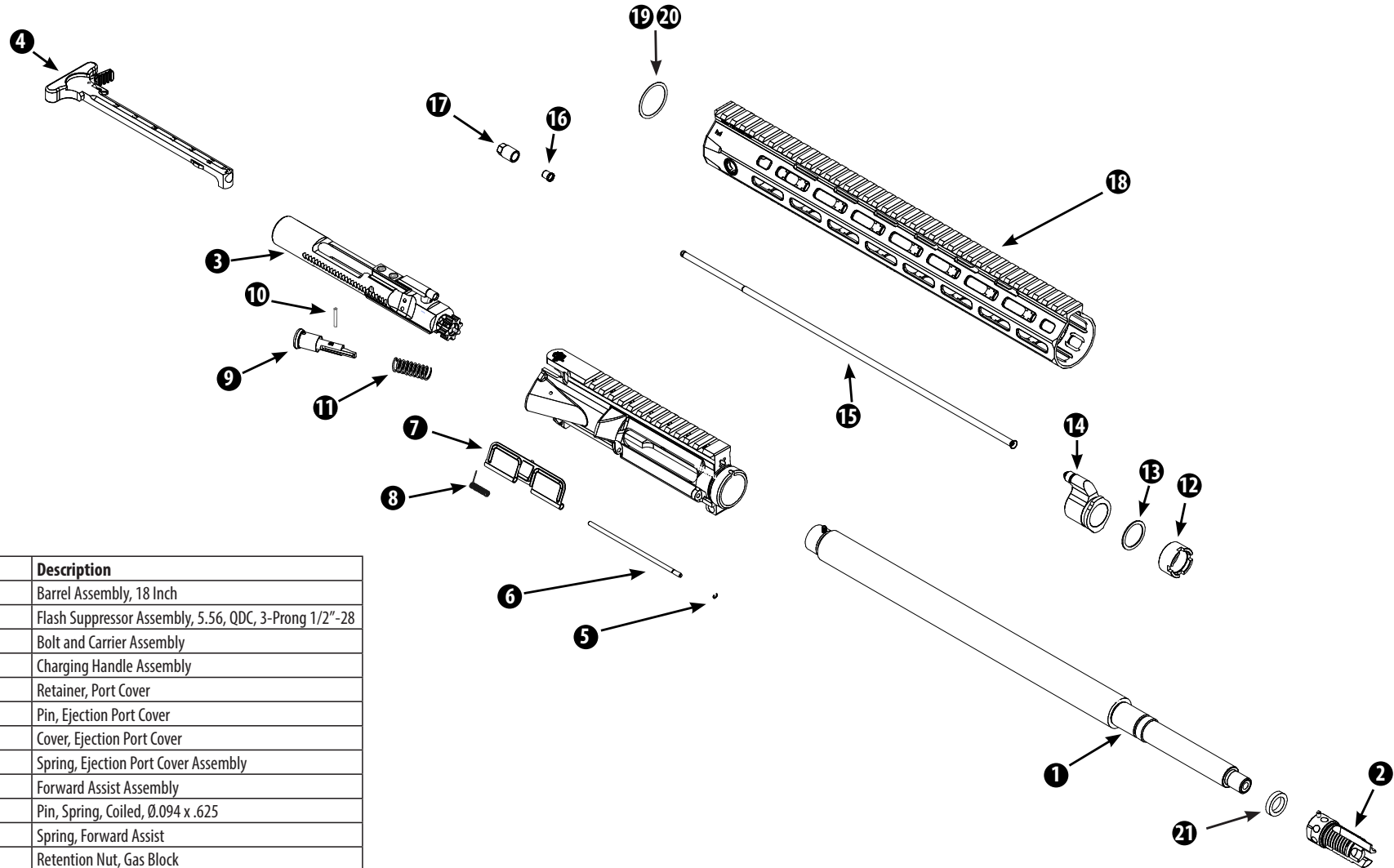

Item #	Part #	Description
1	31745	Barrel Assembly, 18 Inch
2	30495	Flash Suppressor Assembly, 5.56, QDC, 3-Prong 1/2"-28
3	99311-1	Bolt and Carrier Assembly
4	25897	Charging Handle Assembly
5	21513	Retainer, Port Cover
6	21133	Pin, Ejection Port Cover
7	22351	Cover, Ejection Port Cover
8	94049	Spring, Ejection Port Cover Assembly
9	30937	Forward Assist Assembly
10	22102	Pin, Spring, Coiled, Ø.094 x .625
11	21152	Spring, Forward Assist
12	30674	Retention Nut, Gas Block
13	30675	Washer, Gas Block
14	30886	Gas Block Low Profile, A/N Fitting, 5.56 Threaded
15	30580-2	Gas Tube, Carbine
16	30582	Sleeve, Gas Tube
17	30581	Nut, Gas Tube
18	31885-1450	Forend Assembly, 5.56 L1450, URX IBN, M-LOK
18	30902-1	Forend Assembly, 5.56 L1450, URX IBN, Keymod
19	31062-010-BLK	Shim, .010 Thick, Black
20	30299	Shim Set, 5.56 URX IBN (as required)
21	96051	Shim Set, Seven Piece, 5.56 (as required)

9.5" SR-30 E3 MOD 2 UPPER RECEIVER ASSEMBLY

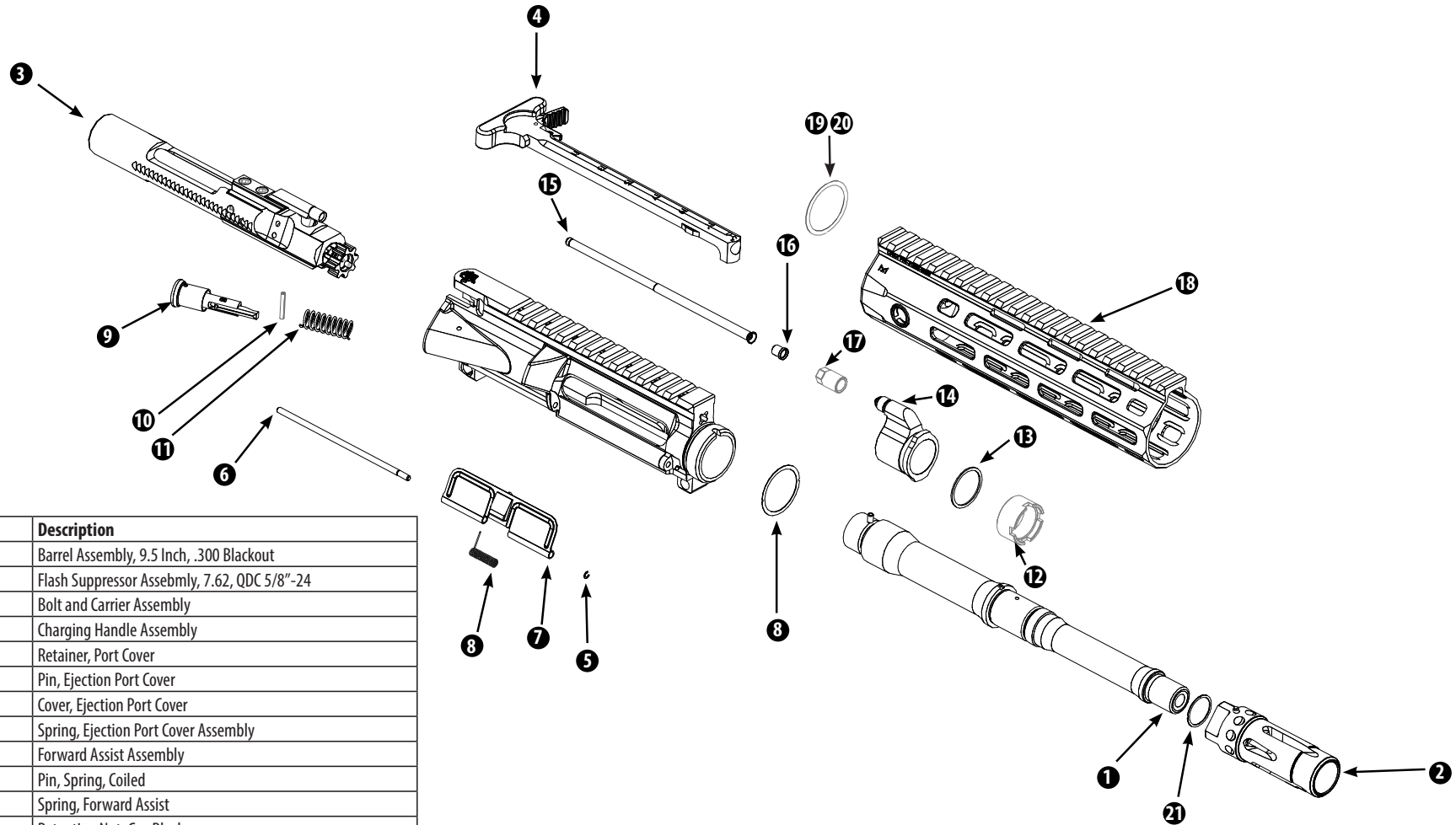

Item #	Part #	Description
1	31557	Barrel Assembly, 9.5 Inch, .300 Blackout
2	30522	Flash Suppressor Assebmly, 7.62, QDC 5/8"-24
3	99311-1	Bolt and Carrier Assembly
4	25897	Charging Handle Assembly
5	21513	Retainer, Port Cover
6	21133	Pin, Ejection Port Cover
7	22351	Cover, Ejection Port Cover
8	94049	Spring, Ejection Port Cover Assembly
9	30937	Forward Assist Assembly
10	22102	Pin, Spring, Coiled
11	21152	Spring, Forward Assist
12	30674	Retention Nut, Gas Block
13	30675	Washer, Gas Block
14	31555	Gas Block, Low Profile, A/N Fitting, .300 Blackout
15	30580-4	Gas Tube, Pistol
16	30582	Sleeve, Gas Tube
17	30581	Nut, Gas Tube
18	31885-0850	Forend Assembly, 5.56 L8.50, URX IBN, M-LOK
18	30905	Forend Assembly, 5.56 L8.50, URX IBN, Keymod
19	31062-010-BLK	Shim, .010 Thick, Black
20	30299	Shim Set, 5.56 URX IBN (as required)
21	96051	Shim Set, Seven Piece, 5.56 (as required)

NOTES



ITAR

International Traffic in Arms Regulations

RESTRICTED EXPORT. The item(s) are firearm or defense related goods governed by U.S. Government International Traffic in Arms Regulations 22 CFR, ITAR Parts 120-130 and therefore require an Export License issued by the U.S. Department of State to be subsequently transported outside of the United States. These items may not be transferred, transhipped on a non-continuous voyage, or otherwise be disposed of in any other country, either in their original form or after being incorporated into other end items. The International Traffic in Arms Regulations (ITAR) is a set of United States government regulations that control the export of defense-related articles and services on the United States Munitions List. These regulations implement the provisions of the Arms Export Control Act, and are described in Title 22 (Foreign Relations), Chapter (Department of State), Sub chapter M of the Code of Federal Regulations.