

SIGSAUER®

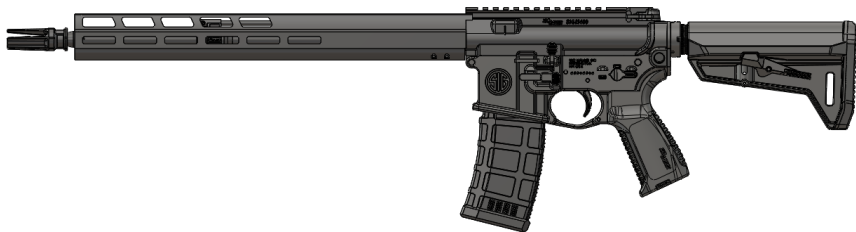

SIG M400 TREAD™ / SIG M400 PRO™ ***OPERATOR'S MANUAL: HANDLING & SAFETY INSTRUCTIONS***

READ THE INSTRUCTIONS AND WARNINGS IN THIS MANUAL CAREFULLY BEFORE USING THIS FIREARM.
DO NOT DISCARD THIS MANUAL.

THIS MANUAL SHOULD ALWAYS ACCOMPANY THIS FIREARM AND BE TRANSFERRED WITH IT UPON CHANGE IN
OWNERSHIP, OR WHEN THE FIREARM IS PRESENTED TO ANOTHER PERSON.





WARNINGS

1.0 Safety Warnings

READ THIS ENTIRE MANUAL THOROUGHLY AND CAREFULLY PRIOR TO USING THIS FIREARM.

The warnings in this operators manual are extremely important. By understanding the dangers inherent in the use of any firearm, and by taking the precautions described in this manual, you can experience a higher level of safety in the use of your firearm. Failure to heed any of these warnings may result in serious injury or death to you or others, as well as severe damage to the firearm or other property.

WARNINGS in this manual identify a clear danger to the person performing that procedure. Warnings are identified by a red banner with the word **WARNING** in black, bold, uppercase letters and a **WARNING** icon. Failure to comply with a **WARNING** can result in serious injury or death to you or a bystander.



WARNING

CAUTIONS in this manual identify a risk of damage the firearm being maintained. **CAUTIONS** are identified by a black banner with the word **CAUTION** in white, bold, uppercase letters.

CAUTION



WARNINGS

SIG SAUER

1.0 Safety Warnings

SIG SAUER firearms are designed to function reliably with proper care and knowledgeable use. You must understand the safe operation and use of your SIG SAUER firearm. Read and follow these directions carefully. Do not use the firearm unless you fully understand these instructions and the safe operation of your firearm. Failure to heed any of these directions may result in serious injury or death to you or others, as well as severe damage to the firearm or other property.

Your firearm comes equipped with effective, well-designed safety features. However, never rely completely on any safety mechanism. Safety mechanisms are designed to augment, not replace safe handling practices. Careless and improper handling of any firearm can result in an unintentional discharge.

Many safety mechanisms are incorporated into your firearm. Only your safe firearm handling habits will ensure the safe use of your firearm. Like all mechanical devices, the safety mechanisms are subject to breakage or malfunction and can be negatively affected by wear, abuse, dirt, corrosion, incorrect assembly, improper adjustment or repair, or lack of maintenance. Moreover, there is no such thing as a safety mechanism that is “childproof” or that can completely prevent accidental discharge from improper usage, carelessness, “horseplay”, or abusive handling.

The best safety is proper and applied training in safe firearm handling. Always handle your firearm as though you expect the safeties not to work.



WARNINGS

1.0 Safety Warnings - Continued

Do not load a cartridge into the chamber until you are ready to use the firearm. If your firearm is equipped with a manual safety, keep the safety ON until you are actually ready to use the firearm. Always move the safety to its intended position and visually check it. The safety is not ON unless it is completely ON.

ABUSIVE HANDLING

All SIG SAUER firearms incorporate effective mechanical safeties. However, like any mechanical device, exposure to abusive conditions may have a negative effect on these safety mechanisms and cause them to fail to work as designed.

Do not subject your SIG SAUER firearm to any type of abusive handling. This includes the firearm being dropped, impact to the firearm, or the firearm being struck by another object.

Make sure you always maintain control of your firearm at all times. If your firearm does suffer an abusive event, as previously described, do not attempt to use the firearm. Keep the firearm pointed in a safe direction, unload and clear the firearm immediately, and have it inspected by a certified SIG SAUER Armorer or gunsmith prior to using the firearm. A safe direction is defined as an area in which, if the firearm were to discharge, no property damage would occur and no personal injury would result.



WARNINGS

SIG SAUER

BASIC RULES OF SAFE FIREARMS HANDLING

1. ALWAYS treat every firearm as if it were loaded.
2. ALWAYS be sure the barrel is clear of any obstruction.
3. ALWAYS be sure of your backstop, what lies beyond, and the safety of bystanders before you shoot.
4. ALWAYS use clean, dry, original factory-made ammunition of the proper type and caliber for your firearm.
5. ALWAYS wear ear protection and safety glasses when shooting.
6. ALWAYS carry your firearm so that you can control the direction of the muzzle if you fall or stumble.
7. NEVER shoot at a flat surface or water.
8. DO NOT leave a loaded fire arm unattended. Firearms and ammunition should be stored separately, locked if possible, beyond the reach of children, careless adults, and unauthorized users.
9. NEVER allow your firearm to be used by anyone who has not read and understood this operators manual.
10. DO NOT point any firearm, loaded or unloaded, at any undesired or unsafe target.
11. NEVER discharge your firearm near an animal unless it is trained to accept the noise. An animal's startled reaction could injure it or cause an accident.
12. NEVER drink alcoholic beverages or take drugs before or during shooting, as your vision and judgment could be seriously impaired, making your firearm handling unsafe.



WARNINGS

1.0 Safety Warnings - Continued

REPLACEMENT PARTS

Do not attempt to disassemble your SIG SAUER firearm beyond the point explained in this manual. Disassembly beyond the instructions in this manual is restricted to a certified SIG SAUER Armorer or Professional Gunsmith. Failure to comply with these restrictions will void your warranty.

Warnings and instructions about the use of some SIG SAUER replacement parts, assemblies, and accessories may be described in literature accompanying the specific products. Read and carefully follow those instructions. Such warnings and instructions are provided to assure the safe functioning of the firearm. Failure to heed them may result in improper functioning, damage to the firearm, and serious injury or death.

ALTERATIONS

This SIG SAUER firearm was designed to function properly in its original condition. Unauthorized alterations can make it unsafe. Do not alter any part or add or substitute any parts or accessories not manufactured by SIG SAUER for this firearm. The addition of any parts or accessories beyond the user level of maintenance described in this manual are not authorized.



WARNINGS

SIG SAUER

1.0 Safety Warnings - Continued

ACCESSORIES

It is your responsibility to ensure all accessories, such as slings, magazines, optics and firearm mounted lights are compatible with this firearm and that the accessories do not interfere with the safe operation and handling of the firearm.

LOCKING DEVICES

This firearm was originally sold with a key operated locking device. While it can help provide secure storage for your unloaded firearm, any locking device can fail. All firearms are designed to fire if they are loaded and the trigger is pulled. Therefore, never install the locking device inside the trigger guard or in any way that makes it possible to pull the trigger!

Do not leave the keys in the lock. The ultimate responsibility for secure storage of any firearm must depend upon its owner and his or her individual circumstances. Firearms should be stored unloaded, in a secure location, separate from their ammunition.

To maximize effectiveness and reduce the chances of malfunction or damage to a firearm, ALWAYS refer to the locking device's manufacturer directions for installation and removal of the device.

FIREARMS SAFETY IS YOUR RESPONSIBILITY



WARNINGS

1.0 Safety Warnings - Continued

State-By-State Warnings

Certain states require, by law, that their own specified warning notices, in larger than-normal type be conspicuously included by the manufacturer, distributor, or retail dealer with firearms sold in that state. SIG SAUER sells its products in compliance with applicable laws and regulations. Because our products may be sold in these states, we include the following:

CALIFORNIA:WARNING

“Children are attracted to and can operate firearms that can cause severe injuries or death. Prevent child access by always keeping guns locked away and unloaded when not in use. If you keep a loaded firearm where a child obtains and improperly uses it, you may be fined or sent to prison.”

ADVERTENCIA

“A los niños atraen las armas de fuego y las pueden hacer funcionar. Ellos pueden causarse lesiones graves y la muerte. Evite que los niños tengan acceso a las armas de fuego guardándolas siempre con llave y descargadas cuando no las esté utilizando. Si usted tiene una arma de fuego cargada en un lugar en que un niño tiene acceso a ella y la usa indebidamente, le pueden dar una multa o enviarlo a la cárcel.”

CONNECTICUT:

“UNLAWFUL STORAGE OF A LOADED FIREARM MAY RESULT IN IMPRISONMENT OR FINE.”



WARNINGS

SIG SAUER

FLORIDA:

"IT IS UNLAWFUL, AND PUNISHABLE BY IMPRISONMENT AND FINE, FOR ANY ADULT TO STORE OR LEAVE A FIREARM IN ANY PLACE WITHIN THE REACH OR EASY ACCESS OF A MINOR UNDER 18 YEARS OF AGE OR TO KNOWINGLY SELL OR OTHERWISE TRANSFER OWNERSHIP OR POSSESSION OF A FIREARM TO A MINOR OR A PERSON OF UNSOUND MIND."

MAINE:

"ENDANGERING THE WELFARE OF A CHILD IS A CRIME. IF YOU LEAVE A FIREARM AND AMMUNITION WITHIN EASY ACCESS OF A CHILD, YOU MAY BE SUBJECT TO FINE, IMPRISONMENT OR BOTH. KEEP FIREARMS AND AMMUNITION SEPARATE. KEEP FIREARMS AND AMMUNITION LOCKED UP. USE TRIGGER LOCKS."

MARYLAND:

"WARNING: Children can operate firearms which may cause death or serious injury. It is a crime to store or leave a loaded firearm in any location where an individual knew or should have known that an unsupervised minor would gain access to the firearm. Store your firearm responsibly!"



WARNINGS

MASSACHUSETTS:

“WARNING FROM THE MASSACHUSETTS ATTORNEY GENERAL:

This handgun is not equipped with a device that fully blocks use by unauthorized users. More than 200,000 firearms like this one are stolen from their owners every year in the United States.

In addition, there are more than a thousand suicides each year by younger children and teenagers who get access to firearms.

Hundreds more die from accidental discharge. It is likely that many more children sustain serious wounds, or inflict such wounds accidentally on others. In order to limit the chance of such misuse, it is imperative that you keep this weapon locked in a secure place and take other steps necessary to limit the possibility of theft or accident. Failure to take reasonable preventative steps may result in innocent lives being lost, and in some circumstances may result in your liability for these deaths.”



WARNINGS

SIG SAUER

MASSACHUSETTS: - Continued

“IT IS UNLAWFUL TO STORE OR KEEP A FIREARM, RIFLE, SHOTGUN OR MACHINE GUN IN ANY PLACE UNLESS THAT WEAPON IS EQUIPPED WITH A TAMPER RESISTANT SAFETY DEVICE OR IS STORED OR KEPT IN A SECURELY LOCKED CONTAINER.”



WARNINGS

NEW JERSEY:

"IT IS A CRIMINAL OFFENSE TO LEAVE A LOADED FIREARM WITHIN EASY ACCESS OF A MINOR."

NEW YORK CITY, NY:

"THE USE OF A LOCKING DEVICE OR SAFETY LOCK IS ONLY ONE ASPECT OF RESPONSIBLE FIREARMS STORAGE. FOR INCREASED SAFETY, FIREARMS SHOULD BE STORED UNLOADED AND LOCKED IN A LOCATION THAT IS BOTH SEPARATE FROM THEIR AMMUNITION AND INACCESSIBLE TO CHILDREN AND OTHER UNAUTHORIZED PERSONS."

NORTH CAROLINA:

Any person who resides in the same premises as a minor, owns or possesses a firearm, and stores or leaves the firearm (i) in a condition that the firearm can be discharged and (ii) in a manner that the person knew or should have known that an unsupervised minor would be able to gain access to the firearm, is guilty of a Class 1 misdemeanor if a minor gains access to the firearm without the lawful permission of the minor's parents or a person having charge of the minor and the minor:

- (1) Possesses it in violation of G.S. 14-269.2(b)
- (2) Exhibits it in a public place in a careless, angry, or threatening manner;
- (3) Causes personal injury or death with it not in self defense; or
- (4) Uses it in the commission of a crime.



WARNINGS

SIG SAUER

TEXAS:

"IT IS UNLAWFUL TO STORE, TRANSPORT, OR ABANDON AN UNSECURED FIREARM IN A PLACE WHERE CHILDREN ARE LIKELY TO BE AND CAN OBTAIN ACCESS TO THE FIREARM."

WISCONSIN:

"IF YOU LEAVE A LOADED FIREARM WITHIN THE REACH OR EASY ACCESS OF A CHILD YOU MAY BE FINED OR IMPRISONED OR BOTH IF THE CHILD IMPROPERLY DISCHARGES, POSSESSES, OR EXHIBITS THE FIREARM."

Please check with your licensed retailer, state police, or local police for additional warnings, which may be required by local law or regulation. Such regulations change constantly, and local authorities are in the best position to advise you on such legal matters.



WARNINGS

1.1 Eye and Hearing Protection

PROTECT YOUR EYES AND EARS



Always wear eye protection that meets the requirements of American National Standards Institute (ANSI) Z87.1 and ear plugs or “ earmuff ” type hearing protectors whenever you are shooting. Always make certain that persons close to you are similarly protected. Unprotected eyes may be injured by powder, gas, carbon residue, lubricant, metallic particles, or similar debris that may emanate occasionally from any firearm in normal use. Without proper hearing protection, repeated exposure to shooting noise may lead to cumulative, permanent hearing loss.



WARNINGS

SIG SAUER

1.2 Ammunition

Use only high quality, original, factory-manufactured ammunition. Do not use cartridges that are dirty, wet, corroded, bent, or damaged. Do not oil cartridges. Do not spray aerosol-type lubricants, preservative, or cleaners directly onto cartridges or where excess spray may flow into contact with cartridges. Lubricant or other foreign matter on cartridges can cause potentially dangerous ammunition malfunctions. Use only ammunition of the caliber for which your firearm is chambered. The proper caliber is permanently engraved on your firearm; never attempt to use ammunition of any other caliber.

The use of reloaded, “re-manufactured” hand-loaded, or other non-standard ammunition voids all warranties. Reloading is a science and improperly loaded ammunition can be extremely dangerous. Severe damage to the firearm and serious injury to the shooter or to others may result. Always use ammunition that complies with the industry performance standards established by the Sporting Arms and Ammunition Manufacturers’ Institute, Inc. of the United States (SAAMI) or ammunition manufactured to military specifications.

SIG SAUER inc. Specifically disclaims responsibility for any damage or injury whatsoever occurring in connection with, or as a result of, the use in any sig sauer firearm of faulty, non-standard, “re-manufactured” hand loaded (reloaded) ammunition, or cartridges other than those for which the firearm was originally chambered.

Firearms may be severely damaged and serious injury to the shooter or to others may result from any condition causing excessive pressure inside the chamber or barrel during firing. Excessive pressure can be caused by obstructions in the barrel, propellant powder overloads, the use of incorrect cartridges or defectively assembled cartridges. In addition, the use of a dirty, corroded, or damaged cartridge can lead to a burst cartridge case and consequent damage to the firearm and personal injury from the sudden escape of high-pressure propellant gas within the firearm’s mechanism.



WARNINGS

1.2 Ammunition - Continued

OBSTRUCTED BORE

Immediately stop shooting and check the barrel for a possible obstruction whenever:

- You have difficulty in, or feel unusual resistance in, chambering a cartridge;
- A cartridge misfires (does not go off);
- The mechanism fails to extract a fired cartridge case;
- Unburned grains of propellant powder are discovered spilled in the mechanism;
- A shot sounds weak or abnormal. In such cases it is possible that a bullet is lodged part way down the barrel.
- Firing a subsequent bullet into the obstructed barrel can wreck the firearm and cause serious injury to the shooter or to bystanders.

Bullets can become lodged in the barrel:

- If the cartridge has been improperly loaded without propellant powder, or if the powder fails to ignite (ignition of the cartridge primer alone will push the bullet out of the cartridge case, but usually does not generate sufficient energy to expel the bullet completely from the barrel);
- If the bullet is not properly seated in the cartridge case. When such a cartridge is extracted from the chamber without being fired, the bullet may be left behind in the bore at the point where the rifling begins. Subsequent chambering of another cartridge may push the first bullet further into the bore.



WARNINGS

SIG SAUER

1.2 Ammunition - Continued

If there is any reason to suspect that a bullet is obstructing the barrel, immediately unload the firearm and look through the bore. It is not sufficient to merely look in the chamber. A bullet may be lodged some distance down the barrel where it cannot easily be seen.

If a bullet is in the bore, do not attempt to shoot it out by using another cartridge or by blowing it out with a blank or one from which the bullet has been removed. Such techniques can generate excessive pressure, damage the firearm, and cause serious personal injury.

If the bullet can be removed with a cleaning rod, clean any unburned powder grains from the bore, chamber, and mechanism, before resuming shooting. If the bullet cannot be dislodged by tapping it with a cleaning rod, take the firearm to a gunsmith.

Dirt, corrosion, or other foreign matter on a cartridge can impede complete chambering and may cause the cartridge case to burst upon firing. A damaged or deformed cartridge may also impede chambering performance and cause the cartridge case to burst upon firing.

Do not oil cartridges, and be sure to wipe the chamber clean of any oil or preservative before shooting. Oil interferes with the friction between cartridge case and chamber wall that is necessary for safe functioning, and subjects the firearm to stress similar to that imposed by excessive pressure.



WARNINGS

1.2 Ammunition - Continued

Use lubricants sparingly on the moving parts of your firearm. Avoid excessive spraying of any aerosol gun care product, especially where it may get on ammunition. All lubricants and aerosol spray lubricants in particular can penetrate cartridge primers and cause misfires. Some highly penetrative lubricants can also migrate inside cartridge cases and cause deterioration of the propellant powder; on firing, the powder may not ignite. If only the primer ignites, there is danger that the bullet may become lodged in the barrel.

Death, serious injury, and damage can result from the use of wrong ammunition, bore obstructions, powder overloads, or incorrect cartridge components. Always wear shooting glasses and hearing protectors. Improper ammunition destroys firearms.



WARNING: CANCER AND REPRODUCTIVE HARM-www.P65warning.ca.gov



DISCHARGING FIREARMS IN POORLY VENTILATED AREAS, CLEANING FIREARMS, OR HANDLING AMMUNITION MAY RESULT IN EXPOSURE TO LEAD AND OTHER SUBSTANCES KNOWN TO THE STATE OF CALIFORNIA TO CAUSE BIRTH DEFECTS, REPRODUCTIVE HARM, AND OTHER SERIOUS PHYSICAL INJURY. MAINTAIN ADEQUATE VENTILATION AT ALL TIMES. WASH HANDS THOROUGHLY AFTER EXPOSURE. SHOOTING OR CLEANING FIREARMS MAY EXPOSE YOU TO LEAD



WARNINGS

SIG SAUER

1.3 Safety Information

This operator's manual is designed to assist you in learning how to use and care for your SIG SAUER® firearm properly.

Only when you are certain that you fully understand this manual and can properly carry out its instructions, should you practice loading and firing your firearm with live ammunition. Having a firearm in your possession is a full-time job; you cannot guess and you cannot forget. You must know how to use your firearm safely.

If you have any doubts about your ability to handle or use this firearm safely, you should seek supervised instruction.

The SIG SAUER Academy provides all levels of firearms safety and skill training, from beginner to expert.

For more information contact:

SIG SAUER[®]
ACADEMY

sigsaueracademy.com • (603) 610-3400
Epping, New Hampshire

SAFETY MUST BE THE FIRST AND CONSTANT CONSIDERATION OF EVERY PERSON WHO HANDLES FIREARMS AND AMMUNITION.

For more information about safety, responsible firearms ownership, and shooting sports, contact:
National Rifle Association (NRA) of America
11250 Waples Mill Road, Fairfax, VA 22030-7400 • 1-800-672-3888
nra.com



Table of Contents

Topic	Page
1.0 Safety Warnings.....	2
2.0 Mechanical Characteristics and Rifle Theory.....	22
2.1 Rifle Description.....	22
2.2 Specifications.....	23
2.3 Controls and Features.....	24
2.4 Groups and Assemblies.....	27
2.5 Cycle of Operation.....	34
3.0 Operating the SIG M400.....	37
3.1 Safety Rules and Procedures.....	37
3.2 Selecting Modes of Fire.....	39
3.3 Clearing the SIG M400.....	40
3.4 Loading/Reloading.....	43
3.5 Adverse/Special Conditions.....	45
3.6 Immediate/Remedial Action.....	46
3.7 Telescoping Stock.....	47
4.0 User Level Authorized Preventive Maintenance.....	48
4.1 Field Strip the SIG M400.....	48
5.0 Cleaning and Lubrication	53
5.1 Cleaning the Bore and Chamber	53

Table of Contents - Continued

Topic	Page
5.2 Cleaning the Bolt Carrier Assembly.....	55
5.3 Lubrication	56
5.4 Reassembly	59
5.5 Function Check.....	65
5.6 Troubleshooting	66
5.7 Lower Receiver Assembly Parts Diagram.....	69
5.8 Upper Receiver Assembly Parts Diagram.....	70
6.0 M400 TREAD Handguard Removal and Installation.....	71
7.0 Transportation and Storage	72
8.0 Service and Replacement Parts Policy.....	74
9.0 Shipping Firearms for Repair.....	77
SIG Sauer Limited Lifetime Firearms Warranty	75



2.0 Mechanical Characteristics and Rifle Theory

2.1 Rifle Description

2.1.1 General

The SIG M400 rifle is a direct impingement rifle with a rotary bolt mechanism capable of semi-automatic and select fire operation. Select fire is available only in the Pro model. The rifle is chambered in 5.56x45mm NATO and is compatible with .223 Remington ammunition.

The SIG M400 has a MIL-STD 1913 rail on top of the upper receiver. The TREAD and PRO versions are fitted with an aluminum handguard with M-LOK™ attachment points. The handguard of the PRO version features a MIL-STD 1913 rail at the 12 o'clock position. Both versions are equipped multiple sling attachment points and 6 position telescoping buttstocks.

2.2 Specifications

VARIANT	M400 TREAD	M400 PRO
CALIBER	5.56x51 mm	5.56x51 mm
MAXIMUM LENGTH	35.8 in. (909.3 mm)	36.6 in. (929.6 mm)
MINIMUM LENGTH	32.6 in. (828.0 mm)	33.4 in. (848.4 mm)
BARREL LENGTH	16 in. (406.4 mm)	16 in. (406.4 mm)
RATE OF TWIST	1:8 in. (203.2 mm)	1:7 in. (177.8 mm)
LANDS AND GROOVES	6	6
MUZZLE THREAD	1/2-28 UNEF	1/2-28 UNEF
HEIGHT	7.25 in. (184.2 mm)	7.25 in. (184.2 mm)
WEIGHT	7 lb. (3.16 kg)	6.5 lb. (2.95 kg)
TRIGGER PULL WEIGHT	5.5 - 9.5 lb. (2.49-4.31 kg)	4.5-6.5 lb. (2.04-2.95 kg)
MAGAZINE (SHIPPED)	30 rd Polymer	30 rd Aluminum
All specification data measured with an unloaded firearm with no magazine, sights or other accessories.		



2.3 Controls and Features

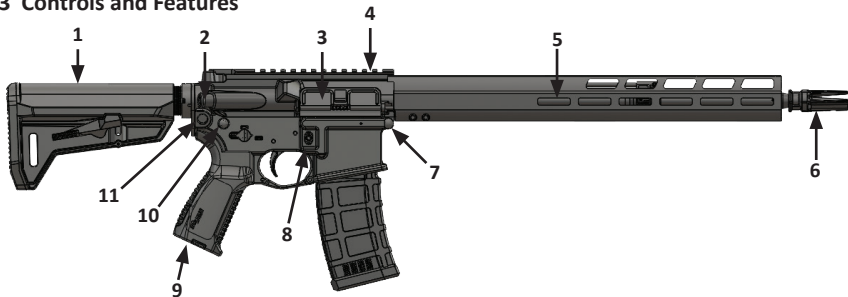

1. Buttstock
2. Forward Assist
3. Ejection Port Cover
4. Mil-Std 1913 Rail
5. M-LOK Mounting Point
6. Flash Hider
7. Pivot Pin
8. Magazine Release Button
9. Pistol Grip
10. Takedown Pin
11. QD Sling Cup (Both Sides)

2.3 Controls and Features - Continued

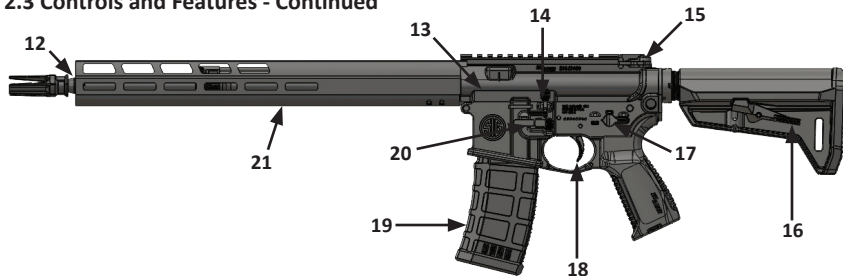

- 12. Barrel
- 13. Upper Receiver
- 14. Bolt Catch
- 15. Charging Handle
- 16. Stock Latch
- 17. Ambidextrous Fire Control Selector
- 18. Trigger
- 19. Magazine
- 20. Ambidextrous Magazine Catch
- 21. Handguard



2.3.1 M400 TREAD

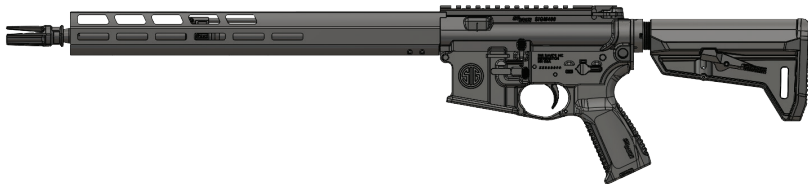

2.3.2 M400 PRO

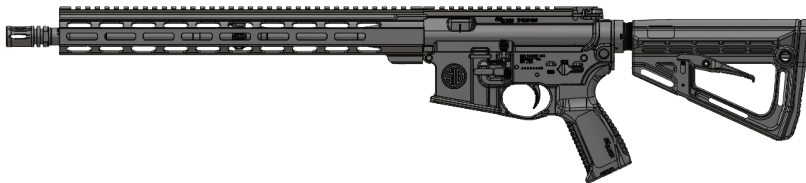

2.4 Groups & Assemblies

2.4.1 Upper Receiver Group

The upper receiver group consists of the following:



a) Charging Handle Assembly

M400 TREAD

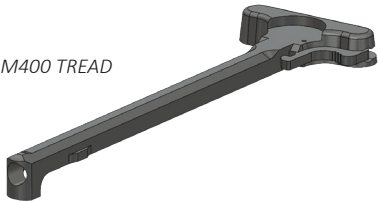

M400 PRO

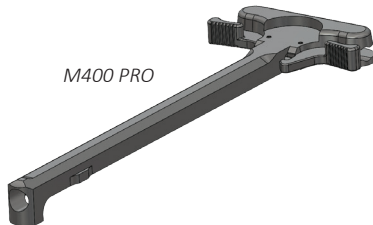

"U.S. patent Nos. 7,900,546 and 7,240,600"



2.4.1 Upper Receiver Group - Continued

b) Bolt Carrier Assembly

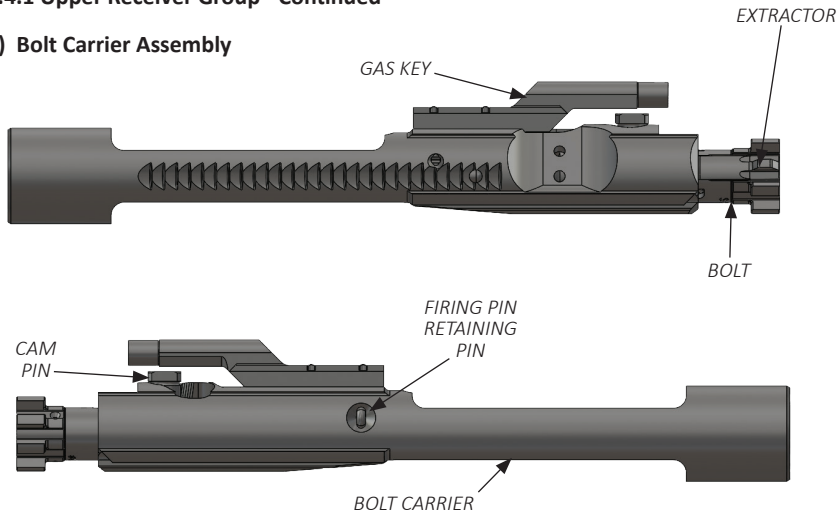

2.4.1 Upper Receiver Group - Continued

c) Upper Receiver and Barrel Assembly

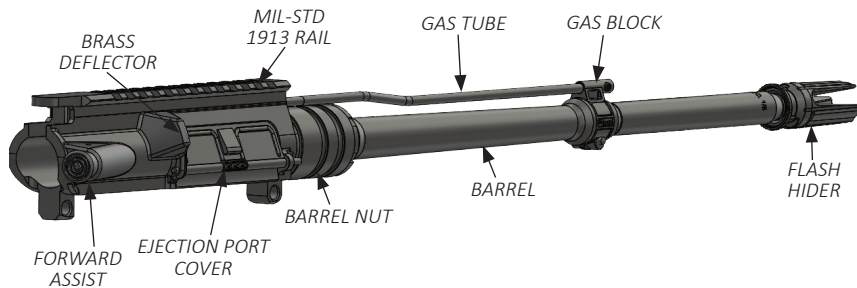

* HANDGUARD REMOVED FOR CLARITY



2.4.1 Upper Receiver Group - Continued

d) Handguard

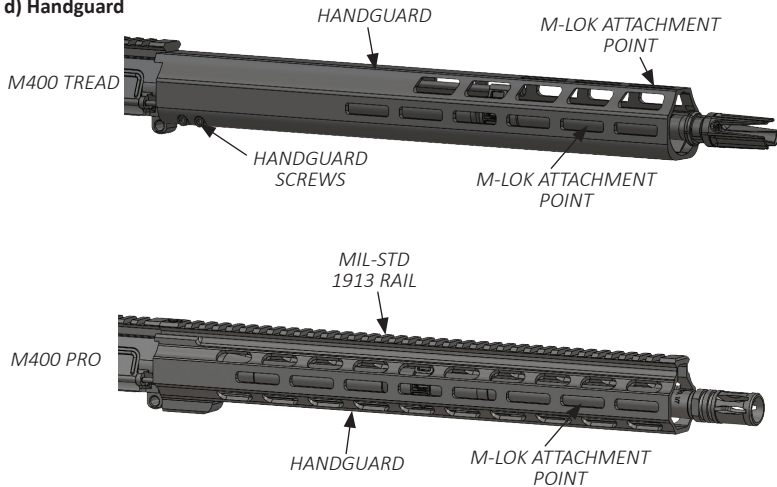

2.4.2 Lower Receiver Group

The Lower Receiver Group consists of the following assemblies: Lower Receiver Assembly with Fire Control Components, Buttstock Assembly, and Grip Assembly.





2.4.2 Lower Receiver Group - Continued

a) Lower Receiver Assembly

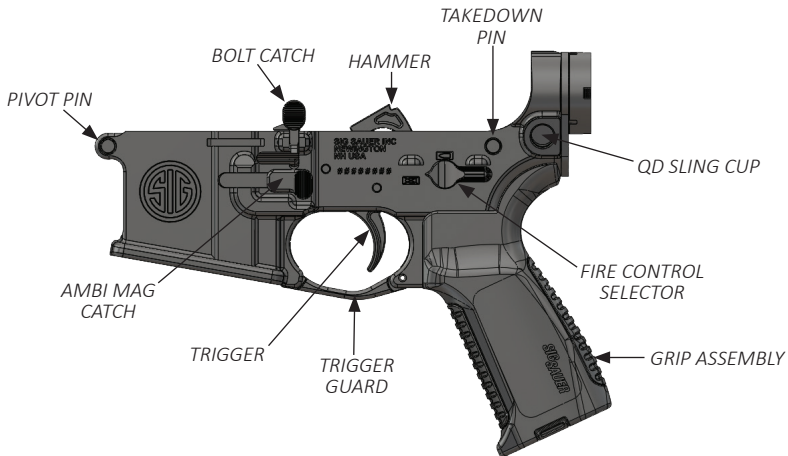

2.4.2 Lower Receiver Group - Continued

b) Buttstock Assembly TREAD

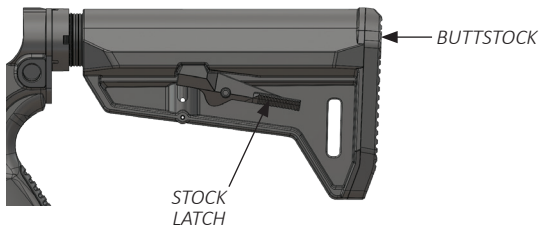

c) Buttstock Assembly PRO

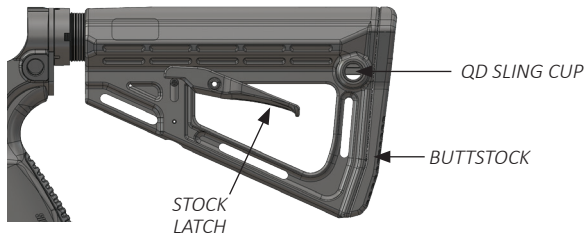



2.5 Cycle of Operation

There are eight steps in the cycle of operation of the SIG M400 which begin after a loaded magazine is inserted into the firearm.

FEEDING

As the bolt carrier is released from its rearward position, the carrier group moves forward allowing the lower lugs of the bolt to make contact with the rear of the cartridge as it sits in the magazine.

The cartridge is stripped from the magazine and begins its forward movement toward the chamber.

CHAMBERING

As the bolt moves forward the bolt locking lugs move forward into the barrel extension. The ejector is then compressed against the left side of the cartridge head.

The last action that occurs is the extractor snapping over the rim of the cartridge case.

2.5 Cycle of Operation- Continued

LOCKING

The movement of the bolt and the cartridge is stopped by the chamber.

The bolt carrier continues to move forward until it is stopped by contact with the rear face of the barrel extension.

As the carrier goes through the last portion of movement, the bolt is rotated to the left, through the action of the cam slot in the carrier and the cam pin through the bolt.

This engages the bolt lugs with the barrel extension lugs to lock the bolt into the barrel extension.

FIRING

The selector is rotated to the Semi or Auto (Pro only) position.

The trigger is pressed and the hammer is released. The hammer spring drives the hammer forward unlocking the firing pin. The firing pin strikes the cartridge primer, causing detonation.



2.5 Cycle of Operation- Continued

UNLOCKING

As the bullet passes the gas port in the barrel, a small amount of gas is bled off, traveling up through the gas port, into the gas block and through the gas tube. This gas drives the bolt carrier rearward. The rearward movement of the carrier causes the bolt cam pin to rotate the bolt to the unlocked position.

EXTRACTION

As the bolt carrier assembly moves rearward the spent case is pulled free from the chamber by the extractor. The twisting motion of the bolt aids in the extraction from the chamber.

EJECTION

The extractor continues to grip the rim of the spent case on the right side. The ejector is applying forward pressure to the left side of the case. As the expended case clears the chamber, then the barrel extension, it is flipped out through the ejector port on the right side of the receiver.

COCKING

The rearward movement of the bolt carrier overrides the hammer, forcing it down into the receiver and compressing the hammer spring, cocking the hammer in the firing position.

3.0 Operating the SIG M400

3.1 Safety Rules & Procedures

Always follow the safety rules and procedures noted in this manual in addition to the safety rules, regulations, procedures or guidelines of your organization.

3.1.1 Safety Rules

- a. Treat every firearm as if it were loaded.
- b. Never point a firearm at anything you do not intend to shoot.
- c. Keep your trigger finger off the trigger and out of the trigger guard until you are ready to shoot.
- d. Keep the firearm on safe until you are ready to shoot.
- e. Be sure of your intended target and know what lies beyond.

3.1.2 Safety Procedures

- a. When handing a firearm to someone else or prior to accepting a firearm from another person, always physically and visually check the chamber so both people can ensure the firearm is unloaded.



3.1.2 Safety Procedures-Continued

- b. Every SIG SAUER firearm is shipped with a chamber safety flag. The chamber safety flag prevents the chambering of a round when installed and provides a readily visible indication that the firearm's chamber is empty. The chamber safety flag is to be installed in the firearm's chamber at all times when not actually on the firing range.
- c. Ensure that unauthorized people never have access to a firearm. Never operate or handle a firearm when you are under the influence of alcohol or drugs.
- d. Be aware of where the muzzle of the firearm is pointed at all times while handling or operating the firearm. Never allow the muzzle to be inadvertently pointed at another person.
- e. Always perform a functions check prior to shooting the firearm (see paragraph 3.5). Do not fire the firearm if it is damaged or it fails functions check.
- f. Always use serviceable, clean ammunition that complies with Sporting Arms and Ammunition Manufacturers' Institute, Inc. (SAAMI) or manufactured to U.S. military or NATO STANAG specification of the proper caliber for the firearm. Never oil or otherwise lubricate ammunition. Do not use damaged or dented ammunition.
- g. Do not fire the firearm if you had a known baffle strike in the suppressor, as this can cause a catastrophic failure to the suppressor or injury to the shooter or bystander should another baffle strike occur.
- h. Live fire firearm's training should always be conducted on an approved firing range conforming to the minimum safety requirements for the caliber and ammunition utilized and under the supervision of qualified range safety personnel.
- i. Always ensure firearms are unloaded prior to storage, maintenance or otherwise not in use.

3.1.2 Safety Procedures-Continued

- j. Any maintenance beyond the user level described in this manual is to be performed by qualified personnel specifically trained on the maintenance of the SIG M400 in accordance with the SIG SAUER 400 Technical Manual.

3.2 Selecting Modes of Fire

The SIG M400 is available in select fire configuration with SAFE-SEMI-AUTO modes of fire. Modes of fire are selected by rotating the selector lever to the desired position. The SAFE position prevents the firearm from firing by blocking the action of the trigger. The SEMI position is for semi automatic mode and allows firing of one round each time the trigger is pressed. AUTO allows for a continuous rate of fire until the trigger is released by the operator, or the magazine is depleted of ammunition. AUTO is available in the Pro model only.

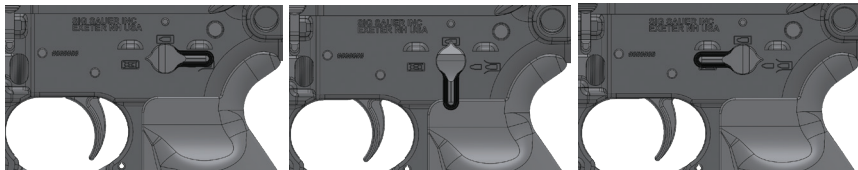
**SAFE****SEMI-AUTO****AUTO**



3.3 Clearing the SIG M400

1. Ensure the muzzle of the firearm is pointed in a safe direction at all times while clearing the firearm.
2. Remove the magazine from the firearm by depressing the magazine catch with the index finger of the firing hand and simultaneously pulling the magazine free with the support hand.

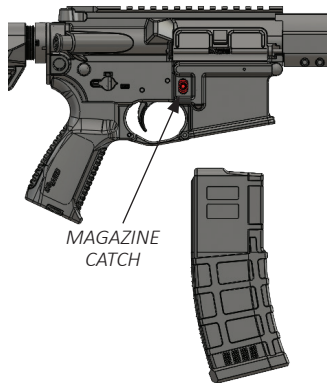

3.3 Clearing the SIG M400 - Continued

3. With the support hand, press and hold the bottom portion of the bolt catch while pulling the charging handle briskly and fully to the rear with the firing hand. Engage the bolt catch ensuring that the bolt carrier assembly remains locked to the rear and return the charging handle to its forward and locked position. Rotate the selector to safe, if it is not already on safe.





3.3 Clearing the SIG M400 - Continued

4. Inspect the chamber to ensure that there are no live rounds or spent cartridges present.

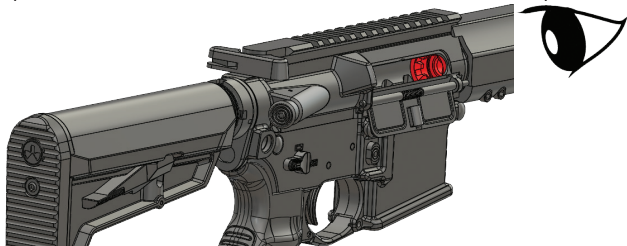

WARNING PARTS UNDER SPRING PRESSURE



THE BOLT CARRIER ASSEMBLY IS UNDER SPRING TENSION AND WILL SPRING FORWARD IF THE BOLT CATCH IS ACCIDENTALLY PRESSED POSSIBLY CAUSING INJURY. DO NOT TO ALLOW THE BOLT CATCH TO BE PRESSED. THE CHAMBER OF THE FIREARM COULD POTENTIALLY BE HOT CAUSING BURNS. WHEN PHYSICALLY INSPECTING THE CHAMBER, USE A PEN OR SIMILAR TOOL IF YOU ARE NOT SURE THE CHAMBER IS COLD.

5. If passing the firearm to another authorized operator, allow that person to inspect the chamber prior to handing over the firearm. Pass the firearm with the bolt locked to the rear and the fire control selector on safe.

3.4 Loading / Reloading

3.4.1 Loading / Bolt locked to the rear

1. Lock the bolt to the rear by pressing inward on the bottom of the bolt catch as you pull charging handle completely rearward.
2. Return the charging handle to the forward locked position.
3. Rotate the fire control selector to the SAFE position.
4. Visually and physically inspect the chamber to ensure it is clear.
5. Insert a loaded magazine until it engages and is held by the magazine catch. Always pull down to ensure the magazine is seated properly.
6. Press the top of the bolt catch inward releasing the bolt carrier. If the firearm is not to be fired immediately close the ejection port cover.

3.4.2 Loading / Bolt forward

1. Insert a loaded magazine until it engages and is held by the magazine catch. Always pull down to ensure the magazine is seated properly.
2. Grasp the charging handle and pull it completely to the rear.
3. Release the charging handle allowing it to go forward under full spring pressure. (DO NOT RIDE IT FORWARD).
4. Rotate the fire control selector to SAFE.



3.4.3 Reloading (Expended magazine/Bolt locked to the rear)

1. Rotate the fire control selector to *SAFE*.
2. Press the magazine catch from either the left or right side. The magazine should fall free from the magazine well.
3. Insert a loaded magazine until it engages and is held by the magazine catch. Pull down to ensure the magazine is seated properly.
4. Depress the top of the bolt catch releasing the bolt carrier forward chambering a live cartridge.

3.4.4 Reloading (Magazine partially expended/Bolt forward, live round chambered)

1. Rotate the fire control selector to *SAFE*.
2. Grasp the magazine with the support hand and depress the magazine catch from either the left or right side.
3. Remove the partially loaded magazine and secure it.
4. Insert a loaded magazine until it engages and is held by the magazine catch. Pull down to ensure the magazine is seated properly.

3.5 Adverse/Special Conditions

Desert

- Apply light lubrication to internal metal on metal moving parts only. If available use dry graphite lubricant.
- Increase frequency of inspection and cleaning of firearm due to blowing dust and sand. Use muzzle covers if available.
- Unload and clean ammunition and inside of magazines daily. Do not lube magazine or ammunition.
- Cover firearm when not in use.
- Close the ejection port cover when not in use.

Arctic

- When operating in sub-freezing temperatures lubricate with LAW. Do not use CLP as it can prevent the firearm from firing. Ensure all existing lubricants are thoroughly removed prior to applying LAW.
- Avoid bringing firearm into heated shelters or buildings to prevent condensation from forming on moving parts which will freeze when the firearm is brought back outdoors.
- If necessary to bring the firearm indoors allow it to warm to room temperature then disassemble and clean thoroughly ensuring all moisture is removed from firearm and re-lubricate with LAW.
- When operating in snowy environments conduct frequent inspection of the firearm to ensure snow has not gotten into operating parts. Work the action to ensure it is not frozen. Use muzzle covers if available.



3.5 Adverse/Special Conditions - Continued

- If the bolt carriage becomes frozen with snow/moisture DO NOT discharge the firearm to free the carriage. Warm firearm with body heat or bring indoors until free movement is restored then clean and re-lubricate the firearm.

Jungle

- Increase frequency of inspection and cleaning of the firearm for rust / corrosion.
- Apply thin coat of lubricant on steel parts frequently.
- Inspect hidden surfaces of bolt and carriage assembly, upper receiver, chamber and barrel extension (locking lugs).
- Inspect the lower receiver for corrosion.
- Inspect and lubricate the spring-loaded detents of the firearm.
- Unload magazine, clean ammunition, and inspect the inside of magazines daily for corrosion.
- Wipe ammunition dry before reloading.

3.6 Immediate / Remedial Action

If the SIG M400 stops firing:

1. Slap up on the bottom of the magazine.
2. Pull charging handle completely rearward.
3. Observe the ejection of the case/cartridge and check the chamber for any obstruction.
4. Release the charging handle to feed a new cartridge.
5. Tap the forward assist to ensure the round is chambered and the bolt is locked.
6. Press the trigger and attempt to fire the rifle.

3.6 Immediate / Remedial Action

If the SIG M400 still fails to fire upon completion of the above steps:

7. Check the chamber for a stuck case.
8. If a case is present separate the receivers and remove the bolt carrier assembly.
9. Attempt to tap out the case with cleaning rod from the muzzle end of the barrel. If the firearm still fails to fire refer to the troubleshooting section of this manual.

3.7 SIG M400 Telescoping Stock

The SIG M400 features a 6 position telescoping stock to accommodate different lengths of pull. To adjust the stock press the stock latch and slide the stock to the desired position and release the latch. Once the stock is positioned, attempt to push the stock back and forth to ensure the stock latch is engaged.

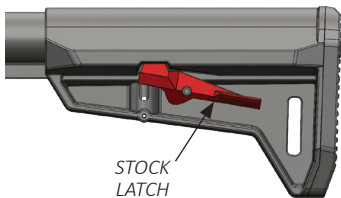

M400 TREAD

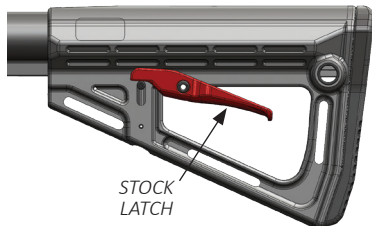

M400 PRO



4.0 User Level Authorized Preventive Maintenance

4.1 Field Strip the SIG M400

1. Unload and clear the firearm, then rotate selector to SAFE.
2. Remove the sling if attached.
3. Push the takedown pin from left to right until stopped by detent.
4. Swing apart the receivers.

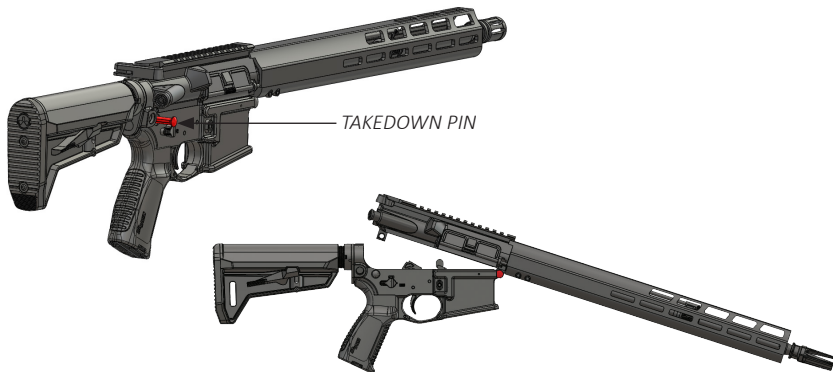

4.1 Field Strip the SIG M400 - Continued

5. Press the pivot pin from left to right until it stops at the detent and separate the upper and lower receivers.



6. Pull the charging handle to start the bolt carrier group out of the upper receiver. Remove the bolt carrier group from the upper receiver.

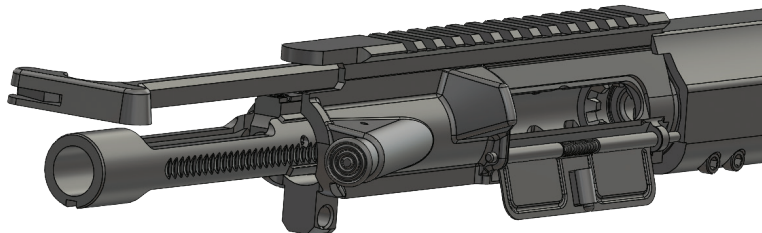



4.1 Field Strip the SIG M400 - Continued

7. Remove the charging handle assembly from the upper receiver by aligning the tabs with the recesses and drop the charging handle assembly out and away.
8. Remove the firing pin retaining in from the bolt carrier then remove the firing pin.
9. Remove the bolt cam pin and bolt from the bolt carrier

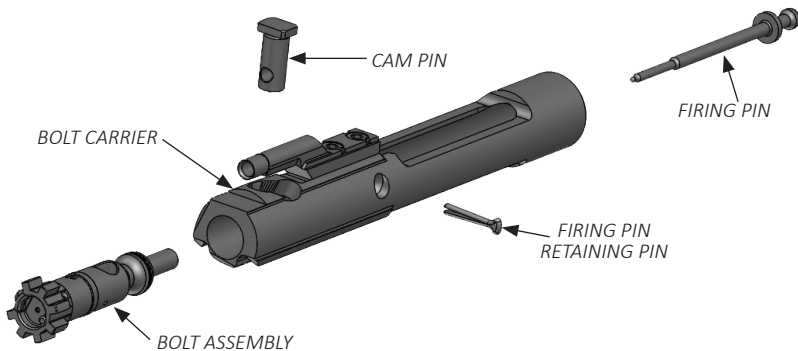

4.1 Field Strip the SIG M400 - Continued

10. Apply slight pressure to the rear of the extractor.
11. Using a small punch or tip of the firing pin push out the extractor pin from either side.

12. Remove the extractor from the bolt. Do not remove the extractor spring, insert, or o-ring from the extractor unless they are being replaced.

EXTRACTOR

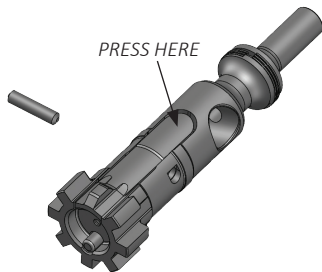
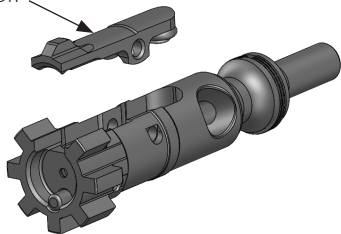



4.1 Field Strip the SIG M400 - Continued

13. Press the buffer retainer and remove the buffer assembly and action spring.
14. Separate the buffer from the action spring.

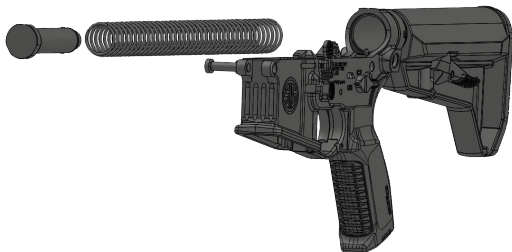
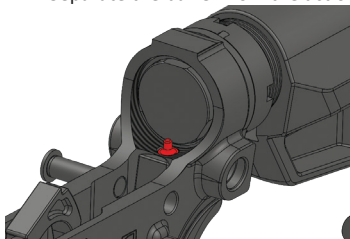

5.0 Cleaning and Lubrication

- Use only cleaning and lubrication products specifically designed for use on firearms.
- Do not use wire brushes on aluminum surfaces such as the upper/lower receivers as this can scratch the finish.
- Follow all manufactures instructions and cautions when using cleaning and lubrication products.
- Wherever the term CLP (Cleaner-Lubricant-Preservative) or the words lube or lubrication are used in this manual it is interpreted to mean that CLP, LSA, or LAW can be utilized as applicable.

5.1 Cleaning the Bore and Chamber

Military sectional cleaning rods if used improperly can be damaged and cause damage to the barrel of the SIG M400. The following steps should be adhered to which will ensure extended use of the cleaning rod assembly. Attempting to push the cleaning rod assembly through the bore from the chamber end could result in the cleaning rod being bent and the metal jag end damaging the chamber and bore.

1. Assemble the rod sections and the jag end to the proper length.
2. Attach a clean patch to the jag.
3. Drop the female end of the cleaning rod through the bore from the chamber end.
4. Attach the cleaning rod handle to the female rod end.



5.1 Cleaning the Bore and Chamber-Continued

5. Apply a coat of CLP or rifle bore cleaner to the patch and slowly pull it through the bore toward the muzzle end.
6. Allow the CLP to sit in the barrel to loosen any fouling.
7. Clean all residue from the bolt, bolt carrier, and cam pin with CLP.
8. Attach a new clean patch to the cleaning rod.
9. Coat the patch as before and pull through the bore from the chamber end as you did with the first patch.
10. Remove the cleaning rod handle and attach the bore brush to the cleaning rod end.
11. Pull the brush through the bore several times to loosen any remaining residue.
12. Pull another patch through the bore with CLP or bore cleaner to remove any heavy residue loosened by the bore brush.
13. Pull new patches through the bore until they come out clean. You should not have to attach the cleaning rod handle to do this.
14. Attach the chamber brush to the rod handle end. Slide a rod section through the hole in the handle to form a T-handle.
15. Coat the chamber brush with CLP or bore cleaner.
16. Keep the muzzle elevated so the CLP does not run into your freshly cleaned bore.
17. Make several plunging strokes followed by several 360 degrees rotations in the barrel extension to clean the locking lug area.

5.2 Cleaning the Bolt Carrier Assembly

- Clean the bolt carrier and bolt body with CLP.
- Clean the cam pin of carbon build up.
- Wipe down the firing pin, firing pin retaining pin and extractor pin.
- Clean any carbon from bolt lugs.
- Clean carbon buildup from bolt channel.
- Clean hook of extractor.

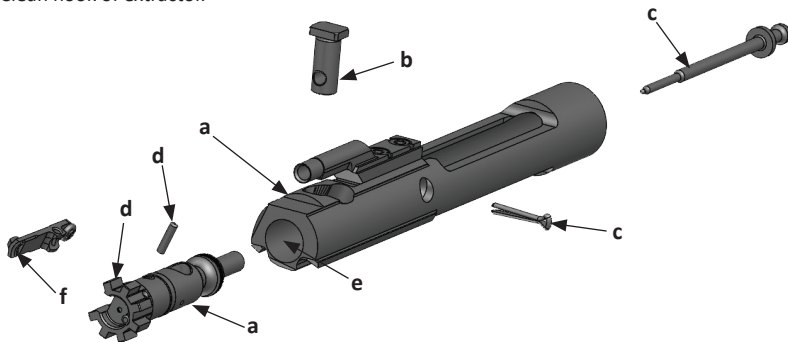



5.3 Lubrication

5.3.1 Bolt Carrier Assembly

- Apply 1-2 drops of lubricant to the cam pin, extractor spring and extractor pin.
- Apply a thin layer of lubricant to the bearing surfaces of the bolt, rear of bolt lugs and bolt carrier.
- Do not lubricate the face of the bolt.

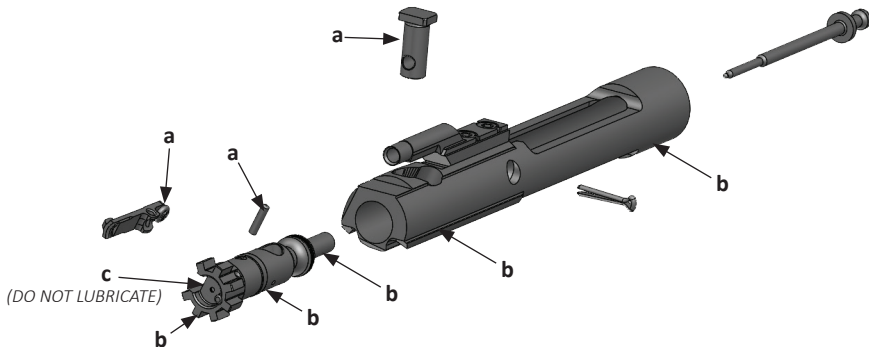

5.3.2 Upper Receiver

- a. Apply a thin film of lubricant to the inside of the upper receiver surfaces where the carriage assembly makes contact.
- b. Apply a thin film of lubricant to the sides of the charging handle.
- c. Apply 1-2 drops of lubricant to the charging handle latch.





5.3.3 Lower Receiver

- a. Apply 1-2 drops of lubricant to the hammer, trigger and bolt catch where these parts contact their respective pins.
- b. Apply 1-2 drops of lubricant to the selector where it contacts the lower receiver.
- c. Apply 1-2 drops of lubricant to pivot pin, takedown pin, and buffer retainer.
- d. Apply a thin film of lubricant to the action spring and buffer.

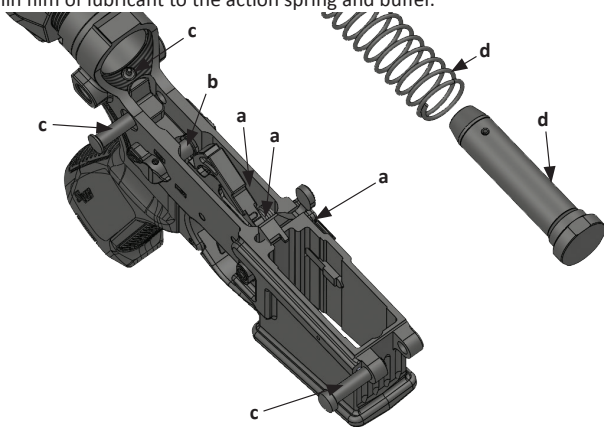

5.4 Reassembly

5.4.1 Assemble Bolt

- a. Place the extractor back into the bolt body and press the rear portion of the extractor while pressing the extractor pin back in place.

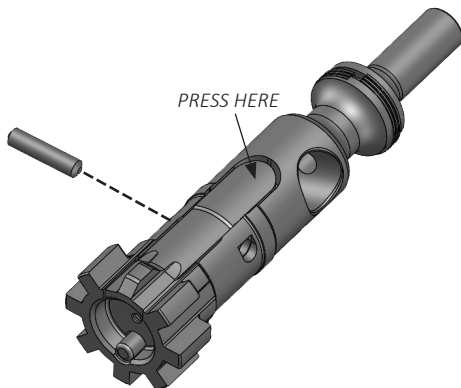



5.4.2 Assemble Bolt Carrier Assembly

- a. Insert the bolt into bolt carrier with the extractor facing right side of carrier.



WARNING ASSEMBLY



FAILURE TO INSTALL CAM PIN MAY RESULT IN INJURY OR DEATH TO THE USER AND CATASTROPHIC DAMAGE TO THE FIREARM.

- b. Install cam pin through bolt carrier and into bolt body.
- c. Pull bolt out to unlocked position. Insert firing pin through rear of bolt and seat firing pin completely forward against bolt.
- d. Insert firing pin retaining pin from the left side of bolt carrier. Ensure the retaining pin is positioned between the head of the firing pin and the large flange.

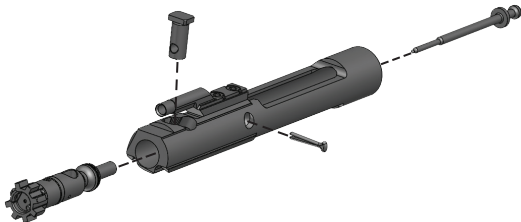

5.4.3 Assemble the Upper Receiver Group.

Position receiver upside-down for steps a-c.

- a. Place the charging handle assembly into the upper receiver so the charging handle lugs align with the recesses in the upper receiver.
- b. Push the charging handle forward slightly to keep it from falling out.

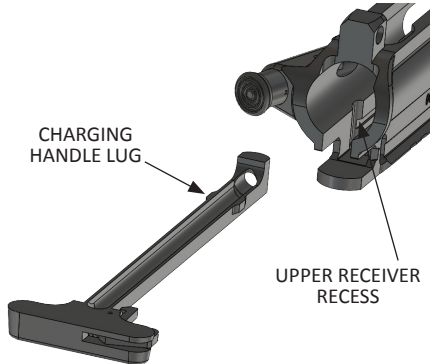



5.4.3 Assemble the Upper Receiver Group-Continued

- c. Pull the bolt completely forward and insert the bolt carrier assembly into the upper receiver.
- d. Push the bolt carrier assembly forward until fully seated.

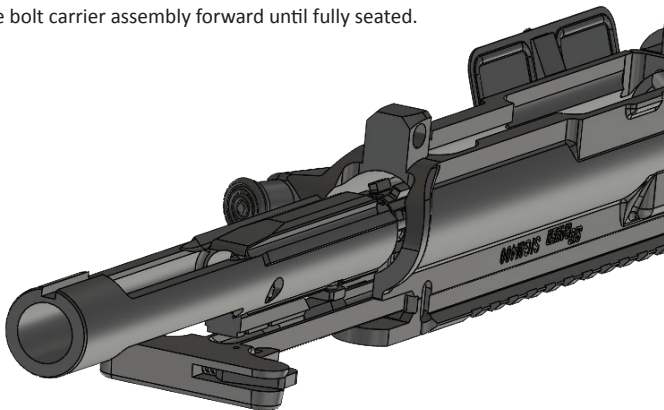

5.4.4 Assemble Lower Receiver

- a. Slide action spring over recoil buffer and snap into place with a clockwise twisting motion as you press spring forward.
- b. Insert action spring into receiver extension. Hammer should be cocked and rifle on SAFE to ease assembly.
- c. Push recoil buffer into receiver extension until it snaps behind buffer retaining plunger.





5.4.5 Assemble the Upper and Lower Receiver Groups.

- a. Align the pivot pin holes of the upper and lower receiver groups and press in the pivot pin.



- b. Close the upper and lower receivers and press the takedown pin fully into the lower receiver.

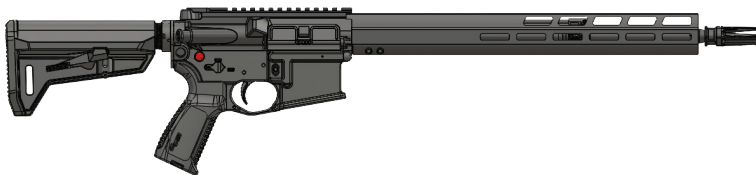

5.5 Function Check

1. Ensure the firearm is unloaded and clear.
2. Insert an unloaded magazine into the magazine well.
3. Fully pull the charging handle until bolt locks to the rear, then press the charging handle forward to lock.
4. Rotate the fire control selector to SAFE.
5. Press the magazine catch. The magazine should fall free of the magazine well.
6. Fully pull and release the charging handle. The bolt catch should disengage and allow the bolt to go forward.
7. Press trigger to the rear. The hammer should not fall.
8. Rotate the selector to SEMI.
9. Press trigger and hold to the rear. The hammer should fall.
10. Fully retract the charging handle cocking the firearm.
11. Slowly release the trigger. You should hear an audible click.



5.6 Troubleshooting

STOPPAGE	TEST/INSPECTION	CORRECTIVE ACTION
Fails to Fire	Selector on SAFE	Rotate to a fire position
	Improper installation of firing pin	Assembly correctly
	Excessive oil in firing pin recess of bolt	Clean out with pipe cleaner
	Defective ammo	Remove / Discard
Bolt Fails to Unlock	Dirty bolt	Clean and re-install
	Burred Bolt Lugs	Contact Customer Service
Failure to Feed	Dirty/Corroded ammo	Clean and replace
	Dirty magazine	Clean and replace
	Defective magazine	Replace
	Overloaded magazine	Remove excess rounds
	Magazine not seated	Check mag catch adjustment
	Under function	Contact Customer Service

5.6 Troubleshooting-Continued

STOPPAGE	TEST/INSPECTION	CORRECTIVE ACTION
Double Feed	Defective magazine	Replace
Failure to Chamber	Dirty/Corroded ammunition	Clean/Replace
	Damaged ammunition	Discard/Replace
	Dirty chamber	Clean
Bolt Fails to Lock	Dirty bolt lugs	Clean lugs
Failure to Extract	Frozen extractor	Remove/Clean
	Broken extractor spring	Contact Customer Service
	Restricted movement of bolt carrier	Remove, clean , lube
	Dirty/Corroded ammo	Remove/clean
	Dirty chamber	Clean
Fails to Lock Bolt to Rear after Last Round	Faulty magazine	Replace
	Broken bolt catch	Contact Customer Service



5.6 Troubleshooting-Continued

Frozen Selector Lever	Needs oil	Lubricate
	Dirt/Residue under trigger.	Clean

5.7 Lower Receiver Assembly Parts Diagram and Parts List

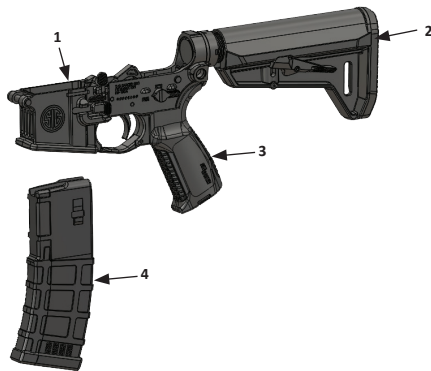

1. Lower Receiver Assembly
2. Stock Assembly
3. Grip
4. Magazine



5.8 Upper Receiver Assembly Parts Diagram and Parts List

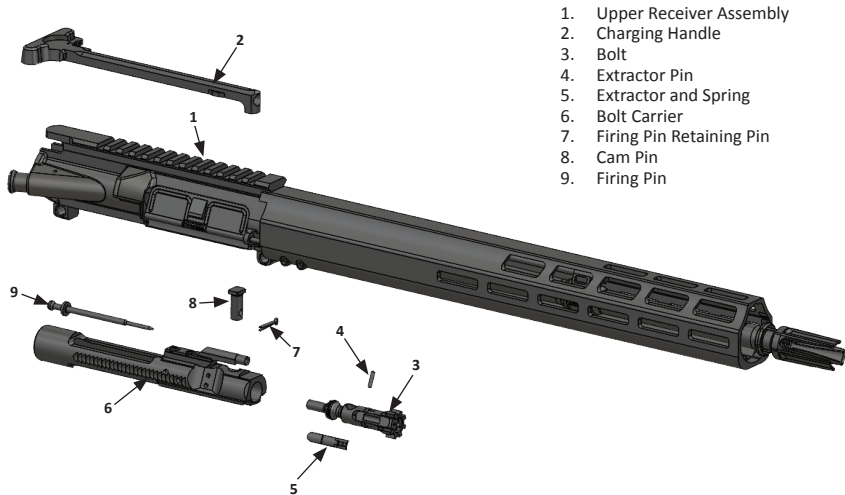

6.0 M400 TREAD Handguard Removal and Installation

NOTE

THIS SECTION APPLIES TO THE M400 TREAD VERSION ONLY. THE M400 PRO HANDGUARD IS NOT REMOVABLE AT THE OPERATOR LEVEL.

1. To remove handguard use a 9/64 inch hex wrench to remove the two handguard retaining screws and slide the handguard forward and off of the upper receiver assembly.

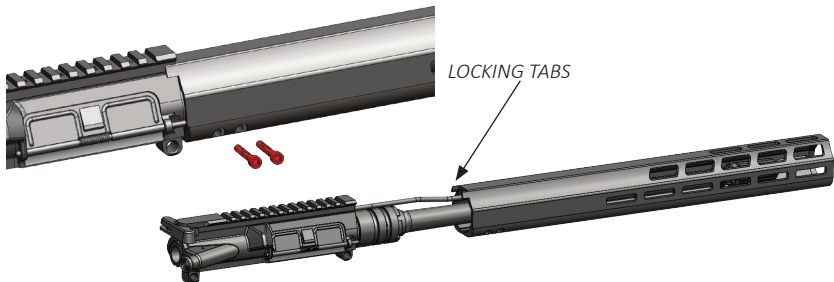

2. To install handguard, slide it onto the upper receiver ensuring the locking tabs are on either side of the upper receiver. Replace the handguard retaining screws and torque to 40 in-lb.



7.0 Transportation and Storage



WARNING - UNLOAD/CLEAR



YOU MUST UNLOAD AND CLEAR THE FIREARM PRIOR TO TRANSPORTING (REFER TO SECTION 3.3). VERIFY THE MAGAZINE IS REMOVED. VISUALLY AND PHYSICALLY CONFIRM THE FIREARM IS UNLOADED AND CLEARED BEFORE TRANSPORTING. FAILURE TO ENSURE THE FIREARM IS UNLOADED AND CLEARED COULD RESULT IN UNINTENTIONAL DISCHARGE, CAUSING INJURY OR DEATH TO YOURSELF OR OTHERS, OR DAMAGE TO PROPERTY.

When transporting your firearm, keep it unloaded for your safety and for the safety of others. When storing your firearm, keep it separated from ammunition, under lock and key if possible, and out of the reach of children and other inexperienced or unauthorized persons.



WARNING - STORAGE



NEVER PLACE OR STORE ANY FIREARM IN SUCH A MANNER THAT IT MAY BE DISLODGED. FIREARMS SHOULD ALWAYS BE STORED SECURELY AND UNLOADED, AWAY FROM CHILDREN AND OTHER UNAUTHORIZED USERS. THE USE OF A LOCKING DEVICE OR SAFETY LOCK IS ONLY ONE ASPECT OF RESPONSIBLE FIREARMS STORAGE. FOR INCREASED SAFETY, FIREARMS SHOULD BE STORED UNLOADED AND LOCKED IN A LOCATION THAT IS BOTH SEPARATE FROM THEIR AMMUNITION AND INACCESSIBLE TO CHILDREN AND ANY OTHER UNAUTHORIZED PERSON.

STORE SECURELY & UNLOADED

7.0 Transportation and Storage-Continued

Short Term Storage (90 days or less)

1. Ensure the chamber and magazine do not contain live ammunition.
2. Clean the bore and chamber
3. Apply a generous coat of CLP to the chamber and bore.
4. Apply a light coat of CLP to all other metal surfaces for corrosion protection.
5. Do not attempt to store any firearm with a warm or hot silencer.
6. If applicable, adjust the buttstock to its shortest length to reduce the chances of damage.

Long Term Storage (90 days or longer)

1. Ensure the firearm is thoroughly cleaned.
2. Apply a medium coat of CLP to the chamber and bore.
3. If applicable, adjust the buttstock to its shortest length to reduce the chances of damage.
4. Apply a light coat of CLP to all other metal surfaces for corrosion protection.
5. Wrap the firearm with a waterproof material (MIL-B-121 or similar).
6. Place the firearm in a corrosion resistant barrier bag (MIL-DTL-117 or similar).

Environmental Storage Recommendations (Armory)

Provide humidity control to limit the relative humidity to no greater than 40% at 80 degrees Fahrenheit (26.7 degrees Celsius). If personnel will be working in these areas, design to 68 deg F (20.0 deg Celsius) dry bulb and 40% RH for indoor design heating conditions, and 75 deg F (23.9 deg Celsius) dry bulb and 40% RH for indoor design cooling conditions.



8.0 Service and Replacement Parts Policy

Parts Policy

Our Service Department maintains a full complement of replacement parts. Even though most gunsmiths have the knowledge, training, and the ability to make necessary repairs to your firearm, the skill and workmanship of any particular 3rd party gunsmith is totally beyond our control.

Should your firearm ever require service, we strongly recommend that you return it to SIG SAUER Inc. A firearm is a precision instrument and some replacement parts will require individual fitting to ensure correct operation. A wrong part, improper fitting, or incorrect mechanical adjustment may result in an unsafe condition or dangerous malfunction, damage to the firearm, or cause possible serious injury to the shooter or others

IF ANY PART IS ORDERED WITHOUT RETURNING THE FIREARM TO SIG SAUER Inc., the customer bears full responsibility for ensuring that the part supplied is correct for their particular firearm and is properly installed and fitted by a qualified gunsmith.

SIG SAUER INC. IS NOT RESPONSIBLE FOR THE FUNCTIONING OF ANY FIREARM IN WHICH REPLACEMENT PARTS ARE INSTALLED BY OTHERS.



WARNING - PARTS PURCHASE

IT IS THE PURCHASER'S RESPONSIBILITY TO BE ABSOLUTELY CERTAIN THAT ANY PARTS ORDERED FROM THE FACTORY ARE CORRECTLY FITTED AND INSTALLED. FIREARMS ARE COMPLICATED MECHANISMS AND IMPROPER FITTING OF PARTS MAY RESULT IN A DANGEROUS MALFUNCTION, DAMAGE TO THE FIREARM, AND SERIOUS INJURY TO THE SHOOTER AND OTHER PERSONS. THE PURCHASER AND INSTALLER OF PARTS MUST ACCEPT FULL RESPONSIBILITY FOR THE CORRECT ADJUSTMENT AND FUNCTIONING OF THE FIREARM AFTER SUCH INSTALLATION.

9.0 Shipping Firearms for Repair

Returning Your Firearm for Service

In the event you need to return your firearm to the SIG SAUER Service Department, here's what to do:

1. The first step is to contact Customer Service at (603) 610-3000 for an RMA number. This number allows SIG SAUER to track the status of your return from its receipt at SIG SAUER through its return to you. Please do not send your firearm until you obtain an RMA number.
2. Make sure the chamber and magazine(s) are unloaded and that no ammunition is included with your returned firearm.
3. Package the firearm securely to prevent damage. Enclose a letter which includes your name, street address, daytime phone number, model and serial number, and a detailed description of the problem you are experienced or the work you want performed. With the exception of extra magazines, do not include scopes, mounts, or other accessories.
4. An individual's ability to legally ship firearms to the manufacturer for repair or service varies according to state and local law. Some jurisdictions require that firearms be shipped and returned by a Federally Licensed Firearms Dealer. Consult applicable law to determine how your firearm should be returned.
5. Federal law prohibits persons who do not possess a federal Firearms License from shipping a firearm via the U.S. Postal Service. (Note: any shipment of firearms outside U.S. borders is subject to the export laws of the United States and to the valid laws of the specific country, which you must strictly follow: prior to exporting any firearm you should seek legal counsel.)
6. SIG SAUER is not responsible for any firearm until it is received, nor for damage incurred during shipment.



9.0 Shipping Firearms for Repair - Continued

7. Ship your firearms insured and prepaid (we do not accept collect shipments) to:

SIG SAUER Inc.
Attention: Service Department
18 Industrial Drive Exeter, NH 03833

This instruction manual should always accompany this firearm and be transferred with it upon change of ownership.



WARNING SHIPPING



BEFORE SHIPPING ANY FIREARM, BE ABSOLUTELY CERTAIN THAT THE FIREARM AND ITS MAGAZINE ARE UNLOADED. DO NOT SHIP AMMUNITION WITH A FIREARM.

ORDER PARTS

In the event you want to order parts for your SIG M400 rifle, contact Customer Service at (603) 610-3000 Ext. 1. Have available the serial number of your firearm and the part diagram number for the part(s) you wish to order. A parts list and diagram of the firearm is provided in this manual.

SIG SAUER® Limited Lifetime Firearms Warranty

SIG SAUER warrants that the enclosed firearm was originally manufactured free of defects in material, workmanship and mechanical function. For the lifetime of the original purchaser, SIG SAUER agrees to correct any defect in the firearm for the original purchaser by repair, adjustment or replacement, at SIG SAUER's option, with the same or comparable quality components (or by replacing the firearms at SIG SAUER's option); provided, however, that the firearm is returned unloaded and freight prepaid to:

**SIG SAUER
18 Industrial Drive
Exeter, NH 03833**

This limited warranty is null and void if the firearm has been misused, damaged (by accident or otherwise), fired with handloaded, reloaded or improper ammunition, fired with an obstruction in the barrel, damaged through failure to provide reasonable and necessary maintenance as described in the manual accompanying the firearm, or if unauthorized repair or any alteration, including of a cosmetic nature, had been performed on the firearm. This limited warranty does not apply to normal wear and tear of any parts. Subject to the foregoing, this limited warranty confers the right to have the covered firearm or its parts repaired, adjusted or replaced exclusively upon the original purchaser, which right is not transferable to any other person. No implied warranties of any kind are made herein and this warranty does not apply to any accessory items attached or appurtenant to the firearm. In no event shall SIG SAUER be liable for any incidental or consequential damages arising from or in connection with this limited warranty.

SIG SAUER®

sigsauer.com

**FOR PRODUCT SERVICE ON THIS MODEL PLEASE CALL
(603) 610-3000 EXT. 1**

**SIG SAUER, Inc.
72 Pease Boulevard, Newington, NH 03801 USA**

All trademarks, service marks, trade names, trade dress, product names and logos appearing in this manual are the property of their respective owners. No trademark or service mark appearing in this manual may be used without written consent of the mark's owner.