



MODERN SPORTING RIFLE

OWNER'S MANUAL



IMPORTANT

READ ALL INSTRUCTIONS AND WARNINGS ON THIS PAGE BEFORE USING THE FIREARM.



WARNING

CHILDREN ARE ATTRACTED TO AND CAN OPERATE FIREARMS THAT CAN CAUSE SEVERE INJURIES OR DEATH.

PREVENT CHILD ACCESS BY ALWAYS KEEPING GUNS LOCKED AWAY AND UNLOADED WHEN NOT IN USE. IF YOU KEEP A LOADED FIREARM WHERE A CHILD OBTAINS AND IMPROPERLY USES IT, YOU MAY BE FINED OR SENT TO PRISON.



ADVERTENCIA

LOS NIÑOS SON ATRAÍDOS POR Y PUEDEN OPERAR ARMAS DE FUEGO QUE PUEDEN CAUSAR LESIONES GRAVES O LA MUERTE.

EVITE EL ACCESO DE NIÑOS MANTENIENDO SIEMPRE LAS ARMAS BLOQUEADAS Y DESCARGADAS CUANDO NO ESTÉN EN USO. SI MANTIENE UN ARMA DE FUEGO CARGADA DONDE UN NIÑO OBTIENE Y LA USA INDEBIDAMENTE, SE LE PUEDE MULTAR O ENVIAR A PRISIÓN.

LIMITED LIFETIME WARRANTY

For the lifetime of the original purchaser, CHRISTENSEN ARMS agrees to correct any defect in the firearm for the original purchaser by repair, adjustment or replacement, at CHRISTENSEN ARMS' sole option, with the same or comparable quality components (or by replacing the firearm at CHRISTENSEN ARMS' option).

FOR MORE INFO SEE PAGE 40

DISCLAIMER

Christensen Arms delivers a firearm free of defects. Our guarantee requires that firearm owners safely handle, properly break-in and properly maintain the firearm. Improper use or owner modifications to the firearm voids the guarantee and warranty.

FOR MORE INFO SEE PAGE 40

BARREL BREAK IN PROCEDURES P.8

BARREL CLEANING PROCEDURES P.22

CONTENTS

02 WARNINGS

03 SAFETY

04 SAFE STORAGE

04 GENERAL INFORMATION

07 INITIAL ASSEMBLY

08 INITIAL CLEANING

08 BARREL BREAK-IN

09 LOADING AND FIRING

12 LOADING CALIFORNIA COMPLIANT

13 LONG TERM STORAGE

14 CLEANING AND UNLOADING

16 DISASSEMBLY

17 DISASSEMBLY CALIFORNIA COMPLIANT

21 MAINTENANCE

28 REASSEMBLY

32 REASSEMBLY CALIFORNIA COMPLIANT

32 FUNCTION CHECK

33 AFTER MARKET PARTS

34 EXPLODED DIAGRAMS

37 TROUBLESHOOTING

40 WARRANTY AND GUARANTEE

41 PRODUCT REGISTRATION

THIS IS CHRISTENSEN ARMS

THE PREMISE IS SIMPLE: BETTER
MATERIALS, ADVANCED PROCESSES,
AND EMPHASIS ON BREAKING WITH
TRADITION.

COMPOSITES
EXCELLENCE
SINCE 1995

MADE IN
THE USA

WARNINGS

THROUGHOUT THIS MANUAL YOU WILL FIND WARNINGS AND/OR CAUTIONS IN BOLD PRINT. ALL WARNINGS AND CAUTIONS SHOULD BE READ CAREFULLY AND FOLLOWED COMPLETELY. WARNINGS DISCUSS ISSUES THAT COULD RESULT IN DAMAGE TO YOUR FIREARM, PERSONAL INJURY OR DEATH TO YOU OR BYSTANDERS. CAUTIONS HIGHLIGHT ISSUES THAT COULD RESULT IN DAMAGE OR MALFUNCTION OF YOUR FIREARM.

WARNING: IT IS YOUR RESPONSIBILITY TO ENSURE THAT YOUR FIREARM IS HANDLED, FIRED, AND STORED SAFELY AND RESPONSIBLY AT ALL TIMES.

THIS MANUAL PROVIDES INSTRUCTIONS ON THE OPERATION AND MAINTENANCE OF YOUR CHRISTENSEN ARMS FIREARM. READ THIS MANUAL CAREFULLY BEFORE USING YOUR FIREARM. YOUR SAFETY AND THE SAFETY OF OTHERS DEPENDS ON YOUR KNOWLEDGE OF THE FIREARM AND YOUR ATTENTION TO FIREARM SAFETY IN GENERAL. PLEASE

STUDY THE SAFETY RULES NOTED IN THIS MANUAL. IT IS YOUR RESPONSIBILITY TO ENSURE THAT YOU COMPLY WITH ALL FEDERAL, STATE AND LOCAL LAWS WITH REGARDS TO THE PURCHASE, OWNERSHIP, USE AND STORAGE OF YOUR FIREARM. THIS MANUAL COVERS SEVERAL CHRISTENSEN ARMS FIREARM MODELS. INSTRUCTIONS REFERRING TO SPECIFIC MODELS WILL BE CLEARLY MARKED.

CHRISTENSEN ARMS IS NOT LIABLE FOR ANY IMPROPER USE OF THE FIREARM AND SHALL NOT BE RESPONSIBLE FOR DAMAGE OF PROPERTY, INJURY OR DEATH RESULTING FROM EITHER ACCIDENTAL OR INTENTIONAL MISUSE OF THIS FIREARM.

CHRISTENSEN ARMS SHALL NOT BE RESPONSIBLE FOR MALFUNCTIONS OF THE FIREARM WHEN IT IS USED FOR PURPOSES FOR WHICH THE FIREARM WAS NOT INTENDED.

CHRISTENSEN ARMS WILL NOT HONOR CLAIMS WHICH MAY RESULT FROM CARELESS OR IMPROPER

HANDLING, UNAUTHORIZED ADJUSTMENTS, PARTS REPLACEMENT, CORROSION, NEGLIGENCE, USE OF THE WRONG TYPE OR CALIBER OF AMMUNITION OR THE USE OF AMMUNITION OTHER THAN ORIGINAL HIGH QUALITY COMMERCIALY MANUFACTURED AMMUNITION IN GOOD CONDITION. CHRISTENSEN ARMS FIREARMS ARE ASSEMBLED USING SPECIFIC TORQUE SPECS AND LOCTITE® ON THREADED COMPONENTS. SOME COMPONENTS ARE EVEN STAKED.

REMOVING OR ADJUSTING SUCH PARTS BEYOND THE SCOPE OF WHAT IS DESCRIBED IN THIS MANUAL COULD RESULT IN PERMANENT DAMAGE TO THE FIREARMS AND COMPONENTS OR PERSONAL INJURY AND POSSIBLY EVEN DEATH.

IT IS NOT ADVISED TO INSTALL AFTER-MARKET PARTS.

SAFETY FIRST, IT IS YOUR RESPONSIBILITY

- Treat every gun as if it is a loaded gun AT ALL TIMES!
- Always keep the muzzle pointed in a safe direction.
- Never point your firearm at anything that you do not intend to shoot.
- Keep your finger off the trigger and out of the trigger guard until you are aiming at your target and ready to shoot.
- Always keep and carry your firearm with an empty chamber until you intend to shoot.
- Firearms should be unloaded when not in use.
- Be sure of your target and backstop before you shoot. Analyze what your bullet will hit if it misses or goes through the target.
- Never shoot at hard, flat surfaces or water.
- Bullets can ricochet.
- Always wear hearing and eye protection when shooting.
- Discharging firearms in poorly ventilated areas, cleaning firearms or handling ammunition may result in exposure to lead, a substance known to be associated with birth defects, reproductive harm, and other serious injuries. Make sure you have adequate ventilation at all times. Wash hands after handling firearms or ammunition.
- Make sure your barrel is clear of all obstructions including (but not limited to) excessive oil, grease, cleaning patches, debris, etc. before shooting.
- Use only clean, high quality factory loaded ammunition in good condition. Christensen Arms does not encourage the use of hand-loaded ammunition.
- Do not alter or modify your firearm.
- Do not try to change your firearm's trigger pull as alterations of trigger pull can affect sear engagement and can cause accidental firing.
- Do not disassemble your firearm's trigger group. Any alteration or adjustment to the trigger group could result in accidental firing causing serious injury or death.
- Store firearms and ammunition separately, and in a safe place out of the reach of children.
- In case of malfunction, STOP! Review this manual to identify and resolve the problem. If you cannot resolve the problem please contact Christensen Arms immediately.
- In case of malfunction, STOP! Review this manual to identify and resolve the problem. If you cannot resolve the problem please contact Christensen Arms immediately.

SAFE STORAGE

WARNING: ALWAYS CHECK TO MAKE SURE YOUR FIREARM IS UNLOADED. ALWAYS STORE YOUR FIREARM IN A SAFE LOCATION SEPARATE FROM THE AMMUNITION.

4 Always make sure both the chamber and magazine are unloaded before placing the firearm in storage. Store your firearm in a securely locked gun safe. If you do not have a gun safe, remove the bolt and bolt carrier assembly from your firearm, and store it separately from the firearm in a secure location. Store your ammunition in a separate location from the firearm and separate from the bolt and bolt carrier assembly.

WARNING: IF YOU HAVE MORE THAN ONE SIMILAR FIREARM, MAKE SURE THAT YOU SPECIFICALLY IDENTIFY THE REMOVED ASSEMBLY WITH ITS ORIGINAL FIREARM AS THE ASSEMBLIES MAY NOT BE INTERCHANGEABLE.

GENERAL INFORMATION

Your firearm is lightweight, gas operated, air cooled and magazine fed. All Christensen Arms firearms are manufactured to perform at a high degree of accuracy, reliability and durability.

WARNING: YOUR CHRISTENSEN ARMS FIREARM WAS DESIGNED AND TESTED TO FUNCTION WITH ITS ORIGINAL COMPONENTS. ALTERATIONS TO THE FIREARM IN ANY WAY, INCLUDING BUT NOT LIMITED, TO ALTERING ORIGINAL COMPONENTS OR REPLACING PARTS WITH AFTER-MARKET (NON-CHRISTENSEN ARMS) PARTS OR COMPONENTS CAN CAUSE MALFUNCTIONS AND WILL VOID YOUR WARRANTY. DO NOT USE SUBSTITUTE PARTS UNLESS THEY ARE MANUFACTURED BY OR RECOMMENDED BY CHRISTENSEN ARMS.

TRIGGER SYSTEM

The Match trigger is factory preset with a pull weight of 3 to 4.5 lbs. The trigger module installs using supplied pins. The trigger is a single stage trigger.

Installation of after-market triggers should be done by an experienced gunsmith.

BARREL LIFE

Christensen Arms Carbon Fiber Barrels and Steel Barrels are an elite choice and upgrade to the AR platform.

Our carbon fiber barrels consists of a stainless steel, select match-grade barrel that has been hand lapped. The steel profile is turned to a proprietary contour and then wound in carbon fiber utilizing a patented process. Chambered to match grade specifications, your Christensen Arms carbon barrel will give the accuracy performance enhancements that are desired in a high end firearm.

PATENT NO.

5804756, 5692334, 5657568, 8677670

RECEIVER FIT

Normal machining and matching variations may result in play or slight side-to-side receiver mismatch. This is not a manufacturing defect.

APPEARANCE

The firearm is an industrial product and bears finishes appropriate for its intended purposes. Christensen Arms firearms are all thoroughly test fired before shipping. New firearms will normally show evidence of this firing. If the receiver looks light or uneven in color which is typically due to dryness, apply a light coat of oil on the metallic surface and this will improve the appearance. Due to the anodization process it is possible to see a slight color difference between

the upper and lower receiver. Christensen Arms matches the upper and lower receivers as best as possible. Any color variation is not a defect. By its very nature the machining process may leave small machine marks on the outside. Christensen Arms inspects all uppers and lowers for extensive marks, but no machined part is free of them. This is not a defect.

WARNING: USE OF INCORRECT AMMUNITION CAN CAUSE FIREARM DAMAGE, PERSONAL INJURY OR DEATH. VISUALLY INSPECT AND CONFIRM THAT YOU ARE USING THE CORRECT CARTRIDGES DESIGNED FOR YOUR FIREARM. DO NOT FIRE OLD, CORRODED, DEFORMED OR HAND LOADED AMMUNITION. IF YOU HAVE ANY QUESTIONS, CONTACT CHRISTENSEN ARMS BEFORE FIRING.

NOTE: Some types/brands of ammunition have unique characteristics (e.g. extremely light or heavy projectiles, particularly soft cartridge cases, propellant that burns unusually slower or more rapidly) which can reduce its reliability in any semiautomatic firearm. Christensen Arms recommends that you purchase and test a small quantity of any type of ammo in your firearm before you buy large quantities.

WARNING: DO NOT FIRE SABOTED AMMUNITION FROM YOUR FIREARM. THE SABOT COULD LODGE IN YOUR MUZZLE DEVICE CAUSING FIREARM DAMAGE AND POTENTIAL INJURY OR DEATH.

CAUTION: TRACER AND ARMOR PIERCING AMMUNITION REDUCES BARREL LIFE.

IF YOU HAVE ANY DOUBTS ABOUT YOUR ABILITY TO HANDLE OR USE THIS FIREARM SAFELY, YOU SHOULD SEEK SUPERVISED INSTRUCTION AND TRAINING. PERSONAL INSTRUCTORS AND GUN SAFETY TRAINING COURSES ARE OFTEN AVAILABLE FROM GUN DEALERS, LAW ENFORCEMENT AGENCIES, GUN CLUBS, AND OTHER SIMILAR LOCATIONS AND GROUPS

INITIAL ASSEMBLY, AND INSPECTION

INITIAL ASSEMBLY

Your firearm is shipped completely assembled. The adjustable butt stock may require adjustment in length for optimal fit.

ADJUSTING THE BUTT STOCK

To extend the collapsible butt stock, depress lever and pull the stock out until it locks into position. To collapse the butt stock, depress the lever again and push forward until it locks into position.

WARNING: IF YOU MOUNT A SCOPE TO YOUR FIREARM, MAKE SURE THE SCOPE IS MOUNTED FAR ENOUGH FORWARD SO THAT IT WILL NOT IMPACT YOUR FACE DURING RECOIL. CHECK THE DISTANCE BETWEEN THE SCOPE AND YOUR FACE WHEN YOU ARE IN THE FIRING POSITION. KEEP IN MIND THAT YOUR EYE WILL BE CLOSER TO THE SCOPE WHEN SHOOTING FROM PRONE OR FROM THE BENCH THAN WHEN SHOOTING OFF-HAND. WHEN IN DOUBT INCREASE THE EYE RELIEF.

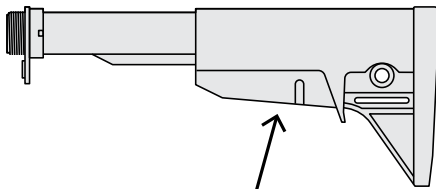

WARNING: READ THIS MANUAL COMPLETELY AS YOU INSPECT YOUR NEW CHRISTENSEN ARMS FIREARM. MAKE SURE YOU UNDERSTAND HOW TO ASSEMBLE, OPERATE, DISASSEMBLE, MAINTAIN, AND STORE YOUR FIREARM SAFELY BEFORE YOU USE IT.

Any time you disassemble and reassemble a firearm, **ENSURE THAT IT IS UNLOADED AND MAGAZINE IS REMOVED.** Then you should conduct a function check.

CHECK YOUR FIREARM'S FUNCTION AS DESCRIBED ON PAGE 32.

INITIAL CLEANING

INITIAL CLEANING

Clean the bore of your firearm and lubricate the firearm as described in the Maintenance section hereafter. A break-in period of 200 rounds allows machined surfaces (including coated surfaces) to smooth out the firearm's action. Lubricate the firearm well before firing.

WARNING: TO ENSURE PROTECTION FROM CORROSION, YOUR CHRISTENSEN ARMS FIREARM HAS BEEN SHIPPED WITH PRESERVATIVE OIL IN THE BORE. FIRING THE FIREARM WITH PRESERVATIVE IN THE BORE CAN INCREASE PRESSURES, WITH POSSIBLE FIREARM DAMAGE, PERSONAL INJURY OR DEATH. CLEAN AND DRY THE BORE BEFORE FIRING YOUR CHRISTENSEN ARMS FIREARM.

DRY FIRING YOUR FIREARM

Dry firing this firearm will not cause damage to the firearm.

CAUTION: NEVER DRY FIRE YOUR Firearm WITHOUT THE BOLT CARRIER ASSEMBLY INSTALLED. THE FIRING PIN STOPS THE FALL OF THE HAMMER, WITHOUT THE BOLT CARRIER ASSEMBLY INSTALLED, THE HAMMER CAN IMPACT ON THE LOWER RECEIVER AND CAUSE DAMAGE TO THE FIREARM.

WARNING: FOLLOW ALL OF THE RULES OF SAFE GUN HANDLING ANYTIME YOU DRY FIRE YOUR FIREARM.

BARREL BREAK-IN

Christensen Arms recommends the following procedures to break in your new match grade barrel.

Go to the URL below for complete instructions to break in your new Christensen Arms barrel.

[CHRISTENSENARMS.COM/BARREL-BREAK-IN](https://christensenarms.com/barrel-break-in)

WARNING: FOLLOW ALL OF THE RULES OF SAFE GUN HANDLING ANY TIME YOU HANDLE YOUR FIREARM.

LOADING AND FIRING

WARNING: ALWAYS KEEP THE SAFETY IN THE "SAFE" POSITION UNTIL YOU ARE READY TO FIRE THE FIREARM. REMEMBER THAT THE SAFETY IS SIMPLY A MECHANICAL DEVICE, AND AS SUCH, COULD POSSIBLY FAIL. ALWAYS KEEP THE CHAMBER EMPTY AND THE FIREARM POINTED IN A SAFE DIRECTION EVEN WHEN THE SAFETY IS ON.

WARNING: INJURY, DEATH OR FIREARM DAMAGE CAN RESULT FROM FIRING A FIREARM WITH AN OBSTRUCTION IN THE BORE. BEFORE YOU FIRE, MAKE SURE THAT THE BORE IS NOT OBSTRUCTED. NEVER ATTEMPT TO SHOOT OUT A BORE OBSTRUCTION.

WARNING: ALWAYS WEAR EYE AND EAR PROTECTION. MAKE SURE THAT BYSTANDERS ALSO WEAR EYE AND EAR PROTECTION.

WARNING: HANDLING OF CARTRIDGES AND FIRING FIREARMS MAY EXPOSE YOU TO LEAD.

ALWAYS ENSURE THAT THERE IS ADEQUATE VENTILATION. ALWAYS WASH YOUR HANDS AFTER HANDLING AMMUNITION OR AFTER FIRING YOUR FIREARM.

WARNING: THIS FIREARM WILL FIRE WITHOUT A MAGAZINE IN IT. ALWAYS MAKE SURE THE CHAMBER IS EMPTY. THE FIREARM SHOULD NOT BE CONSIDERED TO BE SAFE UNLESS THE MAGAZINE IS REMOVED, THE SAFETY IS ON, THE BOLT IS OPEN, AND THE CHAMBER IS EMPTY.

WARNING: THE FIRED CARTRIDGE CASE IS HOT WHEN IT IS EJECTED FROM THE FIREARM.

WARNING: IF THE FIREARM FAILS TO FIRE WHEN THE TRIGGER IS PULLED:

- 1 Keep the firearm pointed at the target or in a safe direction.
- 2 Check to see if the safety is engaged by mistake, if so, push the safety to the "Fire" Position, aim at intended target and fire.
- 3 Remove the magazine

- 4 Ensure the firearm is pointed in a safe direction, open the bolt quickly with the ejection port pointed away from your face and body. Unload the firearm.
- 5 Examine the firearm and cartridge carefully to identify the cause of the malfunction.

WARNING: RAPID FIRING OF THE FIREARM MAY CAUSE SOME COMPONENTS TO BECOME HOT ENOUGH TO CAUSE INJURY. EXTENDED SESSIONS OF VERY RAPID FIRING MAY CAUSE A CARTRIDGE LEFT IN THE CHAMBER TO "COOKOFF," FIRING ITSELF WITHOUT YOU PULLING THE TRIGGER. ALWAYS UNLOAD THE FIREARM IMMEDIATELY AFTER YOU FINISH FIRING.

PREVENT COOK-OFFS AND BARREL LIFE

To prevent cook-offs and maximize barrel life, the rate of fire should not exceed the following:

2 minutes - 40 rounds per minute

10 minutes - 30 rounds per minute

20 minutes - 20 rounds per minute

30 minutes or more - 13 rounds per minute

If you hear a noticeable difference in sound or recoil, **STOP FIRING IMMEDIATELY.** Either situation could mean the powder in the round had an incomplete burn or the bullet is stuck in the bore. If this occurs, remove magazine, retract the bolt slowly and remove the fired case. Keep ejection port pointed away from your face and body. Clear the firearm and check for unburned powder in the receiver and bore. Check to see that the bullet or any other obstruction is not stuck in the bore. If there is unburned powder, clean it out before resuming operation. If a bullet or other obstruction is lodged in the bore, do not attempt to remove it. Take the firearm to a qualified gunsmith.

LOADING THE MAGAZINE

Set the cartridge on the follower between the feed lips making sure it is pointing the same direction as the “bullet” on the follower. Press the bullet straight down until it’s held by the lips of the magazine. Keep your magazines clean and dry. (Never pound the magazine into the firearm. Insert the magazine completely then check to ensure it is locked into the firearm by tugging downward).

CAUTION: DO NOT EXCEED THE INTENDED CAPACITY OF THE MAGAZINE. DUE TO VARIATIONS IN DIAMETERS OF VARIOUS BRANDS OF CARTRIDGES, IT MAY BE POSSIBLE TO FORCE AN ADDITIONAL CARTRIDGE INTO A MAGAZINE. DOING SO WILL DAMAGE YOUR MAGAZINE AND LEAD TO ELEVATED MALFUNCTION RATES.

LOADING THE FIREARM AND CHAMBERING THE FIRST ROUND

- 1 Make sure the firearm is completely unloaded. Pull charging handle rearward, lock the bolt carrier assembly to the rear by pressing the bottom of the bolt stop and then release the charging handle to its latched position. Place safety selector in “SAFE” position. Verify that the chamber is clear and the bore is not blocked.
- 2 Push the magazine up into the receiver until the magazine catch engages and holds the magazine.

CAUTION: KEEP YOUR MAGAZINES CLEAN AND DRY. NEVER POUND THE MAGAZINE INTO THE FIREARM. INSERT THE MAGAZINE COMPLETELY INTO THE FIREARM THEN TUG DOWNWARD TO Ensure IT IS SECURELY LOCKED INTO PLACE.

- 3 Pull down on the magazine slightly to make sure it is locked into place.
- 4 Pull the charging handle completely to the rear and release it to chamber the first round. While it is possible to release the bolt carrier assembly by pushing in on the bolt stop, more energy is provided to chamber the cartridge by pulling the charging handle to the rear and releasing it. If the bolt carrier doesn't fully close, tap the forward assist (if your firearm is so equipped) to close it. If the bolt will not close, clear the firearm and correct the problem.

NOTE: While firing, the bolt carrier assembly will automatically lock to the rear when the last round in the magazine is fired and the firearm is empty. Reload by pressing the magazine catch button to remove the empty magazine, insert a loaded magazine and press the top of the bolt catch or pull the charging handle to the rear and release it (preferred).

CAUTION: NEVER "RIDE" THE CHARGING HANDLE FORWARD. LET IT SLIDE FORWARD AT FULL SPEED

NOTE: The cartridges in a fully loaded magazine can be packed tight and require firm upward pressure to ensure that the magazine catch holds the magazine. It is always easiest to insert the magazine when the bolt carrier assembly is locked to the rear. Using the charging handle to release the bolt carrier assembly provides more energy for chambering.

If your firearm is equipped with a forward assist mechanism, please note that the mechanism is NOT intended to force a cartridge into the chamber if the cartridge does not fully chamber under the power of the recoil spring. If you encounter a cartridge that will not chamber tap the forward assist, if this does not work, remove the magazine and clear the offending round. Clean the firearm if needed, reinstall the magazine and allow the carrier assembly to go

forward under its own power. (If you are not sure you have fully chambered a cartridge, you can partially retract the bolt carrier to visually inspect for a cartridge).

After partially retracting the bolt, the recoil spring may not have enough energy to re-lock the bolt. If this occurs, the forward assist mechanism may be used to re-chamber/re-lock a round that has already been fully chambered.

CAUTION: THE FORWARD ASSIST MECHANISM IS NOT INTENDED TO FORCE THE EXTRACTOR OVER A PARTIALLY CHAMBERED CARTRIDGE. FORCING THE FORWARD ASSIST MAY DAMAGE IT AND MAY RESULT IN A CARTRIDGE THAT IS WEDGED TOO TIGHTLY INTO THE CHAMBER.

LOADING CALIFORNIA COMPLIANT MODELS

The California compliant system consists of a lock that prevents the magazine from being removed from an AR-platform firearm while the action is in the “assembled” state and a spring-loaded button that replaces the rear take-down pin that allows the user to change the action to a “disassembled” state quickly and easily without fully disassembling the firearm.

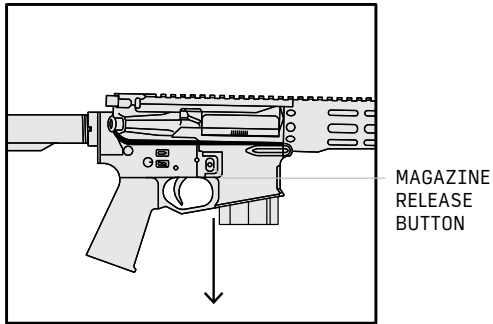
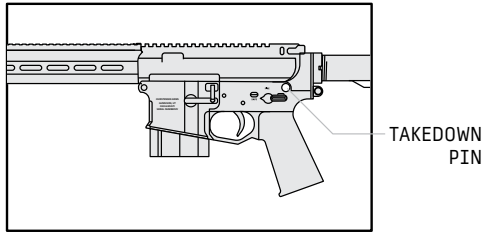

In the “disassembled” state the magazine can be removed and replaced just as with any other AR-platform firearm. The action can then be placed in the “assembled” state by pressing the upper and lower receiver together.

The system comes fully installed upon request and is installed on all Christensen Arms modern sporting firearms sold in the state of California.

FIRING

Aim at the target keeping finger off the trigger until ready to fire. Set the safety selector to the "FIRE" position, grip the firearm firmly, and pull the trigger increasing the pressure until the shot fires. Notice the safety selector is set up to have a 90 degree throw. Do not attempt to push it beyond its intended limit.

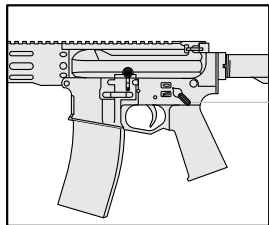

SAFETY SELECT

WARNING: KEEP THE SAFETY ON SAFE AND FINGER OFF THE TRIGGER UNTIL YOU ARE READY TO SHOOT. UNLOAD AND CLEAR YOUR FIREARM BEFORE LEAVING THE SAFE POSITION. CAUTION: DO NOT REST THE FIREARM ON ITS MAGAZINE WHEN YOU ARE LOADING OR FIRING IT. DOING SO CAN FORCE THE MAGAZINE UP INTO THE FIREARM, REDUCING THE RELIABILITY OF FEEDING CARTRIDGES.

LONG TERM STORAGE

Clean your firearm well and apply a good quality firearm protectant.

It is at least theoretically possible for some springs to take a set during prolonged storage. To preclude this possibility, Christensen Arms offers the following recommendations regarding long term storage of your firearm.

Clear all cartridges from your firearm. Remove the magazine. Pull back the charging handle and visually confirm that the chamber is empty and that there is no cartridge held to the bolt face by the extractor. Then check it again. While pointed in a safe direction dry fire the firearm to re-set the hammer to the fired position.

It is always best to store your magazines empty. However if you need to store them loaded, we recommend that you store them with 5 rounds less than their stated capacity.

CLEANING/UNLOADING THE FIREARM

WARNING: ALWAYS ASSUME ALL FIREARMS ARE LOADED. ANYTIME YOU HANDLE A FIREARM, YOU SHOULD IMMEDIATELY INSPECT IT TO ENSURE THAT IT IS COMPLETELY UNLOADED.

WARNING: YOU MUST KNOW HOW TO UNLOAD AND CLEAR YOUR FIREARM.

Keep your firearm cleared when not in use.

- 1 Place safety selector in the "SAFE" position.

NOTE: if the firearm is not cocked, the lever cannot be pointed toward SAFE.

- 2 Remove the magazine by depressing the magazine release button and pulling the magazine down.

CAUTION: THE MAGAZINE WILL FALL FREE WHEN THE MAGAZINE RELEASE IS PRESSED. DON'T ALLOW THE MAGAZINE TO FALL ONTO A HARD SURFACE. DOING SO MAY DAMAGE THE MAGAZINE

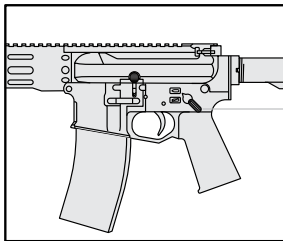

SAFETY SELECTOR

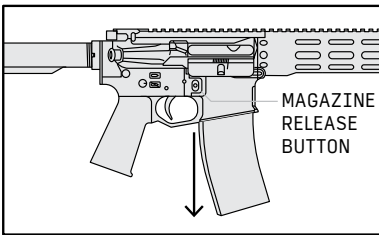

MAGAZINE
RELEASE
BUTTON

- 3 Extract the cartridge (if any) from the chamber. To lock the bolt open, pull the charging handle rearward, press the bottom of the bolt stop, and allow the bolt to move forward until the bolt stop restrains it. Return the charging handle forward.

Note: If your firearm is California compliant it will not be possible to lock the bolt to the rear.

- 4 Look into the receiver and chamber to ensure that these areas contain no ammunition.
- 5 Empty all remaining cartridges from your magazine.

WARNING: THE STEPS IN UNLOADING YOUR FIREARM MUST BE FOLLOWED IN THE EXACT ORDER GIVEN. THE MAGAZINE MUST BE REMOVED BEFORE THE CHAMBER IS INSPECTED. IF YOU CLEAR THE CARTRIDGE FROM THE CHAMBER AND THEN CLOSE THE BOLT WHILE A LOADED MAGAZINE IS STILL ATTACHED, THE FIREARM WILL CHAMBER ANOTHER CARTRIDGE FROM THE MAGAZINE AND THE FIREARM WILL STILL BE LOADED. REMEMBER THAT A CARTRIDGE IN THE CHAMBER CAN STILL BE FIRED EVEN AFTER THE MAGAZINE IS REMOVED.

WARNING: NEVER ASSUME THAT THE CHAMBER IS EMPTY UNTIL YOU HAVE VISUALLY EXAMINED IT AND SEE THAT IT IS EMPTY.

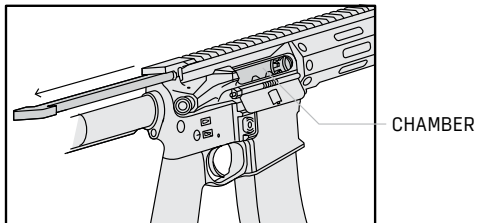

DISASSEMBLY

WARNING: ALWAYS UNLOAD YOUR FIREARM BEFORE CLEANING, LUBRICATION, DISASSEMBLY OR REASSEMBLY.

WARNING: ALWAYS WEAR SAFETY GLASSES WHEN DISASSEMBLING, MAINTAINING OR ASSEMBLING YOUR FIREARM.

CLEARING THE FIREARM

IMPORTANT: Put the safety selector in the "SAFE" position. Remove the magazine, THEN pull back the charging handle and check the chamber.

UPPER AND LOWER RECEIVERS

- 1 Press take-down pin from the left side then pull until it stops.
- 2 Pivot the upper receiver from the lower receiver.

- 3 Press pivot pin from the left side then pull until it stops.
- 4 Separate the upper and lower receivers.

CAUTION: EXCESS FORCE CAN SEVERELY DAMAGE THE RECEIVER.

Note: The CA 9mm has slightly different takedown procedures and parts. As you read the takedown procedures notice the special instructions for these parts.

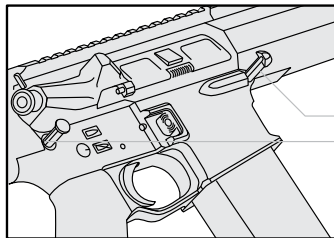

PIVOT PIN
TAKE DOWN PIN

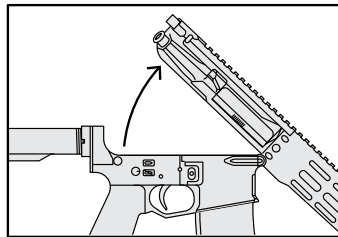

DISASSEMBLY (CALIFORNIA COMPLIANT)

The California compliant kit is an easy-to-use and easy-to-install system that allows AR-platform users to comply with California state laws that require the use of fixed magazines in semi-automatic firearms with certain features.

1. Remove the button and spring from the left-hand side of the action.
2. Keeping the upper receiver pressed into the lower receiver, push or pull the pin until it stops.

3. Rotate the pin 90 degrees counterclockwise and pull the pin until the upper receiver can pivot freely about the front take-down pin.

DO NOT PULL THE PIN COMPLETELY CLEAR OF THE LOWER RECEIVER. COMPLETELY REMOVING THE PIN FROM THE RECEIVER WILL MAKE IT DIFFICULT TO REINSTALL THE PIN WITHOUT THE CORRECT KNOWLEDGE OR TOOLS.

4. The firearm can now be fully disassembled as with any other AR-platform firearm.

CHARGING HANDLE AND BOLT CARRIER ASSEMBLY

- 1 Pull back the charging handle and bolt carrier assembly toward the rear of the firearm.
- 2 Remove the bolt carrier group.
- 3 Pull the charging handle back and down to remove it.

STEP 1

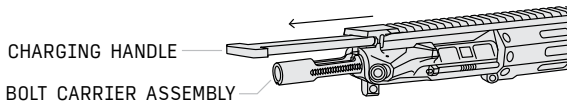

STEP 2

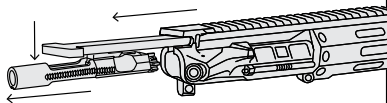

STEP 3

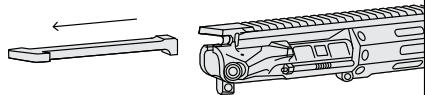

DISASSEMBLY (cont)

- 4 Move the bolt assembly forward to the unlock position and remove the firing pin retaining pin. Do not open or close the split end of the firing pin retaining pin. (9MM Models will not have a bolt Assembly, The firing pin is under spring pressure so slowly allow the firing pin and spring to move from the firing pin channel.)

- 5 Push in on the bolt assembly to put it in the locked position
(9MM Models will not have a bolt Assembly)
- 6 Catch the firing pin as it drops out of the rear of the bolt carrier assembly.
(This will end the Disassembly process for the 9MM Models)
- 7 Lift out the cam pin by rotating 90°.

- 8 Remove the bolt assembly from the bolt carrier assembly.
- 9 Press the rear of the extractor to check that the spring works.

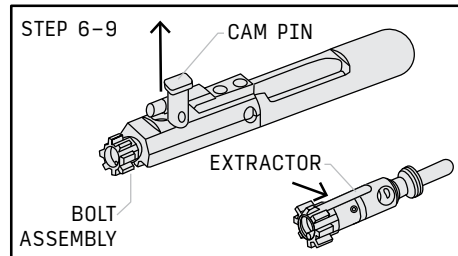
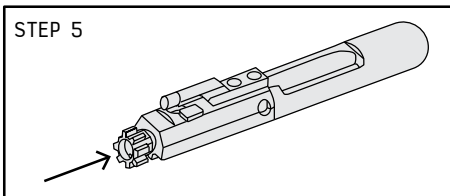
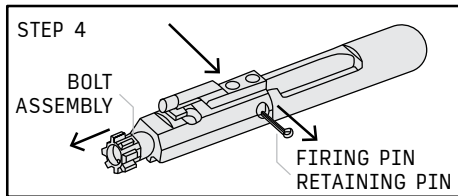

REMOVING BUFFER AND BUFFER SPRING

- 1 Compress buffer detent
- 2 Remove buffer and buffer spring from buffer tube.

CAUTION: BUFFER SPRING IS COMPRESSED AND WILL PROJECT OUT OF TUBE WHEN BUFFER DETENT IS COMPRESSED.

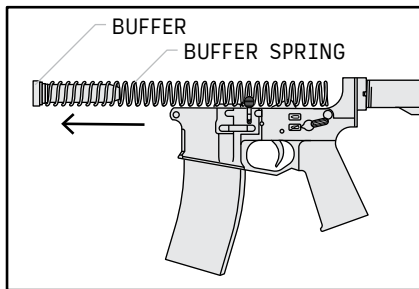
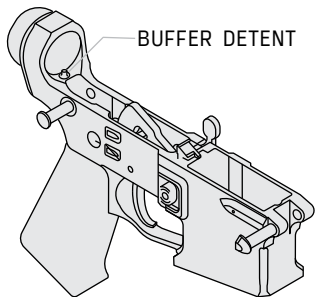

MAINTENANCE

WARNING: ALWAYS UNLOAD YOUR FIREARM BEFORE CLEANING, LUBRICATION, DISASSEMBLY OR REASSEMBLY.

WARNING: DO NOT APPLY LUBRICANT TO YOUR AMMUNITION. DOING SO MAY CAUSE THE CARTRIDGE TO PARTIALLY MALFUNCTION, LEAVING THE BULLET LODGED IN THE BORE, CREATING A BORE OBSTRUCTION.

CLEANING SOLVENTS AND LUBRICANTS

We recommend using high quality solvents to remove metal fouling from the bore and increase reliability and service life.

Lubricate your firearm (especially the highly stressed bolt and bolt carrier assembly) generously with high quality firearms lubricants.

Under NO condition should any lubricant containing graphite be used with your firearm.

Graphite can encourage rapid corrosion to the aircraft-grade aluminum used in your firearm.

In addition to cleaning solvents and lubricants, the basic cleaning equipment you will need includes a cleaning rod, a brass bore brush, chamber brushes, a toothbrush, patches, pipe cleaners, and the most important item: a lint-free cloth. Christensen Arms recommends a pull through cleaning cable for efficient breech-to-muzzle cleaning.

UPPER RECEIVER AND BARREL ASSEMBLY

NOTE: Do not reverse the direction of the bore brush while it is in the bore.

1. Use cleaning solvent on the bore and chamber, the gas tube, the upper receiver and barrel assembly, locking lugs and all areas of powder fouling, corrosion, dirt and dust.

Use a cleaning rod, bore brush and cleaning solvent. Run the rod through the chamber and flash suppressor (if applicable) several times.

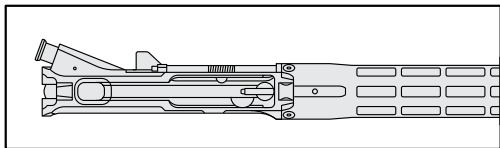

CARBON FIBER MAINTENANCE

- Clean with any household cleaner
- Use gun oil on the barrel and wipe dry to restore original look.

WARNING: LEAD MAY BE PRESENT IN THE FOULING OF A DIRTY FIREARM. AVOID CONTACT WITH IT, AND CLEAN HANDS AFTERWARD TO AVOID INGESTING LEAD.

2. Install the chamber brush on the cleaning rod, dip it in cleaning solvent and insert into the chamber and locking lugs. Clean by pushing and twisting the cleaning rod.

3. Use a toothbrush to clean the outside surface of the protruding gas tube, (get the sides and bottom from the bottom of the upper receiver).

NOTE: Gas tubes will discolor from heat. Do not try to remove this discoloration.

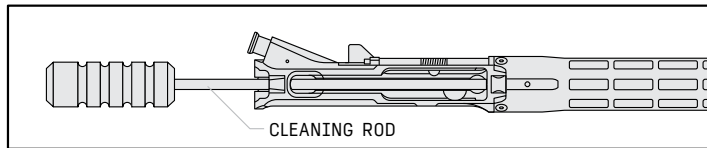

MAINTENANCE (cont)

CAUTION: DO NOT TRY TO CLEAN THE INSIDE OF THE GAS TUBE.

CAUTION: DO NOT BEND THE GAS TUBE. IF THE TUBE IS BENT IT WILL SLOW OR BLOCK FORWARD MOVEMENT OF THE BOLT CARRIER ASSEMBLY.

- 4 Take the bore brush off the rod and install a swab holder and swab. Apply cleaning solvent to the swab, then run it through the chamber and out the muzzle device (if applicable). To remove carbon build up, let the solvent sit, then wipe clean. A bore brush may be used with care to remove heavy carbon buildup. Wipe the bore dry by running clean swabs all the way through from the chamber to the muzzle device.

REMEMBER: DO NOT CHANGE DIRECTIONS IN THE BORE. INSPECT THE BARREL, GAS TUBE AND HAND GUARDS FOR CRACKS, BENDS OR BREAKS. BE SURE THE BARREL HAS NO OBSTRUCTIONS.

- 5 With a lubricated swab, run the rod from the receiver to the muzzle device (if applicable). Do not over lubricate.
- 6 Lubricate the locking lugs.

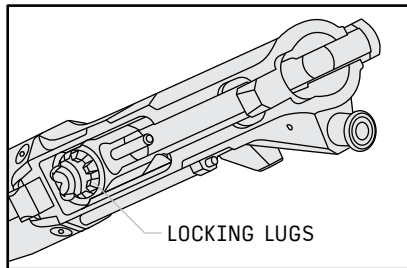

CHARGING HANDLE AND BOLT CARRIER ASSEMBLY

- 1 Clean all parts and outer surfaces of the bolt carrier assembly with a swab saturated with cleaning solvent.
- 2 Clean the bolt carrier key with a worn bore brush dipped in solvent and dry with a pipe cleaner.
- 3 Remove carbon deposits and dirt from the locking lugs with a bore brush dipped in solvent.
- 4 Clean the areas behind the bolt ring and under the lip of the extractor.
- 5 Press the ejector in repeatedly to remove accumulated brass shavings from

the ejector hole and ensure the ejector moves freely. Lubricate it generously.

- 6 Inspect the charging handle for cracks, bends or breaks.
- 7 Inspect the bolt assembly for cracks or fractures, especially in the cam pin-hole area.
- 8 Inspect the firing pin retaining pin for bends, breaks or dents.
- 9 Inspect the cam pin for cracks or chips.

9MM MODEL

Note: The CA9MM bolt face is integral with the carrier.

- 1 Clean the bolt face of any brass shavings or powder fouling.
- 2 Visually Inspect the firing pin hole for any cracks or uneven wear.
- 3 Visually inspect the extractor hook for any damage and with a brush, clean any material from underneath it.

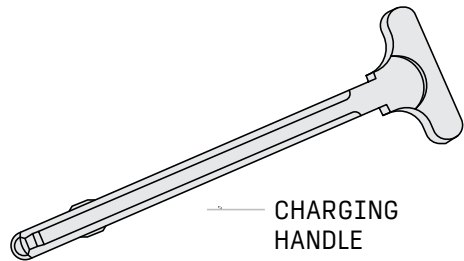
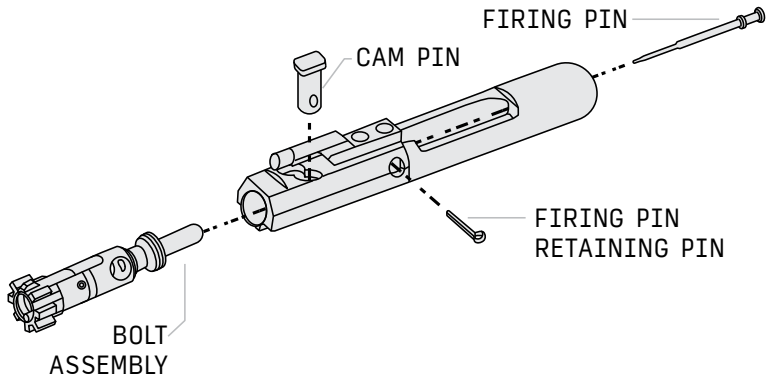

MAINTENANCE (cont)

- 26
- 10 Inspect the firing pin for bends, cracks, chips or a blunted tip.
 - 11 Lightly lubricate the firing pin and firing pin recess in the bolt assembly.
 - 12 Generously lubricate the outside of the cam pin and the firing pin retaining pin. Make certain to lubricate the cam pin hole, bolt ring and outside of the bolt.
 - 13 Lightly lubricate the inner and outer surfaces of the bolt carrier. Generously lubricate the side and the cam pin area of the bolt carrier.
 - 14 Lightly lubricate the charging handle.
 15. Dry the key of the bolt carrier assembly with pipe cleaner. Place one drop of lubricant inside the bolt carrier key.

NOTE: Carbon in the groove at the bottom of the gas cylinder in the carrier cannot accumulate enough to become a problem. Efforts to remove it may cause more damage than leaving it. Avoid the instinct to over-clean your firearm.

LOWER RECEIVER ASSEMBLY

CAUTION: DO NOT USE A WIRE BRUSH OR ANY TYPE OF ABRASIVE MATERIAL TO CLEAN ALUMINUM SURFACES

- 1 Wipe dirt from the trigger with a swab.
- 2 Use a swab and cleaning brush to clean powder fowling, corrosion and dirt from the lower receiver.
- 3 Use pipe cleaner to clean the butt stock screw vent hole.
- 4 Clean the buffer, operating spring and the inside lower receiver with a swab dipped in solvent.
- 5 Lightly lubricate the buffer and operating spring.

- 6 Examine the lower receiver assembly for a broken or bent trigger, butt stock, corroded or deformed lower receiver, cracked or damaged grip, broke hammer spring and bent or damaged safety. Look at the inside parts for cracks, dents or breaks.
- 7 Generously lubricate the take-down, pivot pins, and the inside parts of the lower receiver assembly.

CAUTION

DO NOT ALLOW THE HAMMER TO SWING FREELY AND IMPACT THE LOWER RECEIVER AS THIS COULD DAMAGE THE LOWER RECEIVER. USE A SWAB TO WIPE CLEAN THE SEAR SURFACE OF THE HAMMER. ONCE WIPED CLEAN, APPLY LUBRICANT LIBERALLY TO THE SEAR SURFACE.

WARNING

DO NOT DISASSEMBLE THE TRIGGER GROUP.

REASSEMBLY

WARNING: ALWAYS UNLOAD YOUR FIREARM BEFORE CLEANING, LUBRICATION, DISASSEMBLY OR REASSEMBLY.

LOWER RECEIVER ASSEMBLY

Insert buffer spring and buffer.

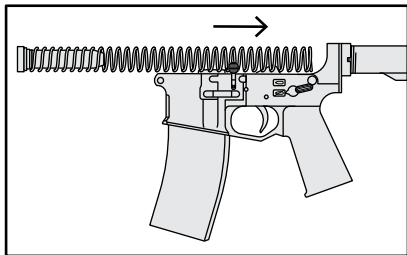

CHARGING HANDLE AND BOLT CARRIER

- 1 Slide the bolt assembly into the bolt carrier assembly.

NOTE: Make sure the extractor is facing to the right side and ejector is facing to the left side.

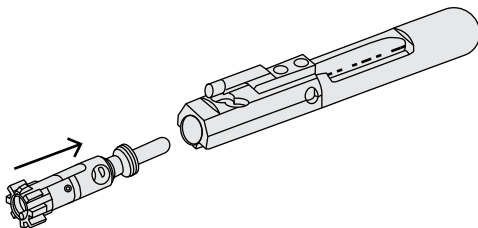

CAUTION: ONLY INSERT THE BOLT INTO THE CARRIER FAR ENOUGH TO INSERT THE CAM PIN. IF YOU INSERT THE BOLT TOO DEEPLY WITHOUT THE CAM PIN IN PLACE, THE BOLT RING MAY JAM IN THE BACK OF THE CARRIER. IF THIS HAPPENS, YOU MAY NEED TO WIGGLE THE BOLT TO REMOVE IT. IN SOME CASES IT MIGHT REQUIRE DRIVING THE BOLT FORWARD WITH A BRASS ROD, DESTROYING THE BOLT RING. ONCE THE CAM PIN IS IN PLACE, THE BOLT CANNOT BE PUSHED FAR ENOUGH INTO THE CARRIER TO CAUSE A PROBLEM.

- 2 Rotate 90° to align firing pin clearance hole.
- 3 Drop firing pin into its opening.

CAUTION: THE TIGHT END OF THE FIRING PIN SPRING ENGAGES A GROOVE ON THE FIRING PIN WHICH PREVENTS LOSING THE SPRING. DURING ASSEMBLY OF THE BOLT CARRIER GROUP, PRESS THE FIRING PIN FORWARD ABOUT 1/8 INCH AFTER FEELING SPRING RESISTANCE. HOLD THE FIRING PIN IN AND INSERT THE FIRING PIN RETAINING PIN.

- 4 Pull the bolt assembly forward and insert the firing pin retaining pin in the area behind the large flange of the firing pin.

CAUTION: DO NOT POUND OR FORCE THE FIRING PIN RETAINING PIN INTO POSITION; IT MAY BE DAMAGED OR CAUSE IT TO BECOME DAMAGED.

- 5 Turn the bolt carrier assembly up and try to shake out the firing pin. The firing pin should remain in place.

WARNING: BE SURE CAM PIN IS INSTALLED IN THE BOLT GROUP. THE FIREARM CAN STILL FIRE WITHOUT IT AND IT WILL EXPLODE.

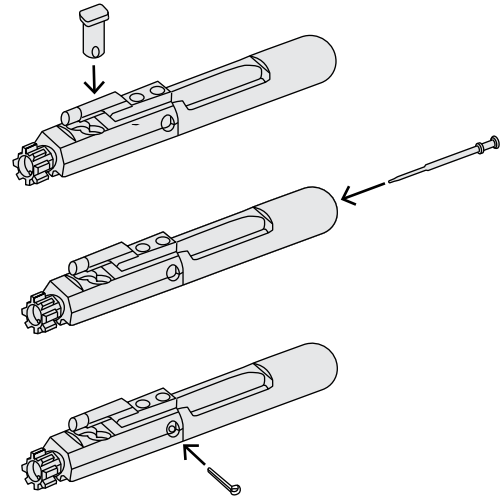

REASSEMBLY (cont)

- 6 Place the charging handle into the upper receiver and engage the handle's lugs with the track in the receiver, then push the charging handle part way into the upper receiver.
- 7 Slide the bolt carrier assembly, bolt extended, into the upper receiver.
- 8 Push the charging handle assembly and bolt carrier assembly together into the upper receiver.

30

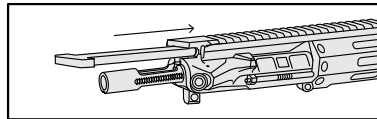
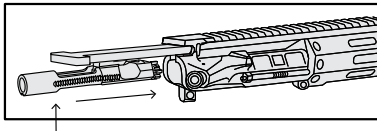
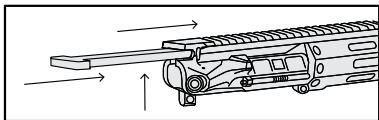

UPPER AND LOWER RECEIVERS

NOTE: The hammer must be in cocked position to join the receivers.

- 1 Join the upper and lower receivers.
- 2 Align the pivot pin holes with the pivot pin and push the pivot pin in.

CAUTION: TO AVOID DAMAGE TO THE EJECTION PORT COVER, CLOSE THE EJECTION PORT COVER BEFORE THE RECEIVERS ARE JOINED.

- 3 Close the upper and lower receivers. Push in the take-down pin.

NOTE: Normal manufacturing variations may result in slight play between the upper and lower receiver. This will not affect function or accuracy.

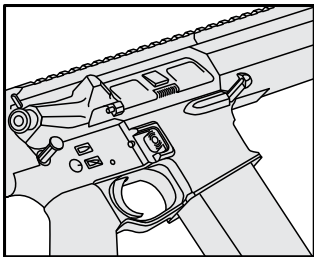
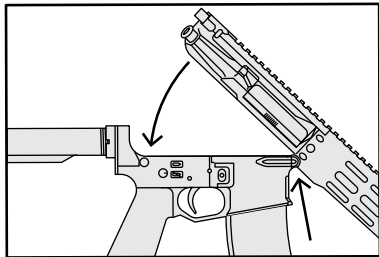

REASSEMBLY (CALIFORNIA COMPLIANT MODELS)

To reassemble the upper receiver and lower receiver of a modern sporting firearm equipped with a Hellfighter magazine lock kit follow these steps:

- 1 Align the holes for the front pivot pin.
- 2 Place the pivot pin through the holes.
- 3 Pivot the upper receiver down into the lower receiver and press the two halves together to align the holes for the take-down pin.
- 4 Push the pin part of the Hellfighter push-button (the part with the female threads) through the holes until it stops.
- 5 Rotate the pin clockwise by 90 degrees.
- 6 Push the pin the rest of the way through the holes.

7 Place the spring over the pin.

8 Screw the button part of the kit back into the pin.

The Hellfighter magazine push-button is now fully assembled.

FUNCTION CHECK

- 1 Remove the magazine and visually inspect the chamber to ensure that it is empty. Install an empty magazine and ensure that it is caught solidly by the magazine catch. Remove the magazine.
- 2 Install magazine, pull the charging handle to the rear and then manually return it forward. The bolt should remain to the rear against the bolt stop. Remove the magazine. Press in the bolt stop. The bolt carrier assembly should be propelled forward by the operating spring.
- 3 Place the safety in "SAFE" position. Ensure the chamber is empty. Squeeze the trigger. The hammer should not fall.

AFTER MARKET PARTS

Christensen Arms is aware that many after-market parts are available for the AR-15 platforms. It is not recommended that these parts be used as it could affect the firearm's functionality. Any adjustments or modifications made beyond the scope of this manual should be done by an experienced gunsmith. Alterations or changes to original manufactured firearm could result in voiding the warranty and eligibility for continued customer support.

- 4 Make sure there is no round in the chamber. Place the safety in "FIRE" position. Squeeze the trigger and hold the trigger to the rear, the hammer should fall. Pull the charging handle to the rear while continuing to hold the trigger back and release the bolt carrier assembly. Release the trigger. You should hear a click as you release the trigger. Squeeze again: the hammer should fall.

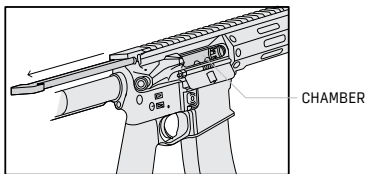

SPECS

- Each screw is torqued to 20 in/lbs
- Screws on the gas block are locked in place using high temperature Rocksett®.
- Hand-guard screws are locked in place using Loctite.
- The barrel nut is torqued to 100 ft/lbs.
- DO NOT substitute factory style screws with any other style as this may cause unpredictability and damage to the firearm. For example.

DO NOT SWAP OUT FLATHEAD SCREWS WITH HEX HEAD SCREWS.

LOWER ASSEMBLY EXPLODED DIAGRAM

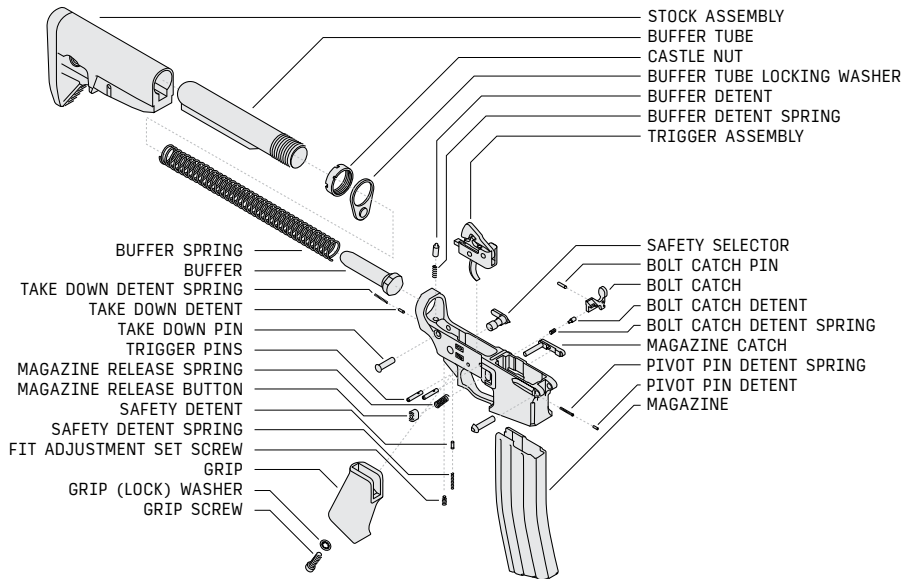

UPPER ASSEMBLY EXPLODED DIAGRAM

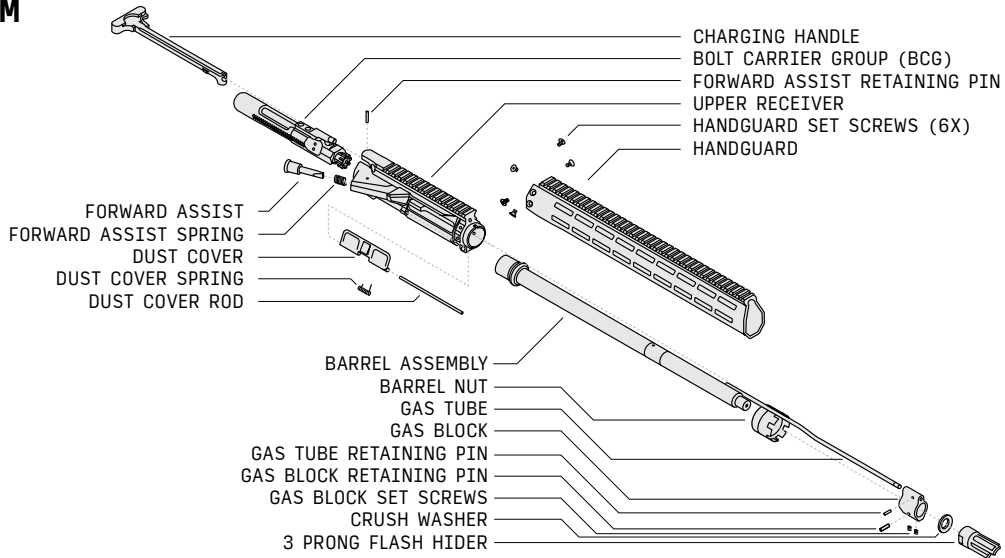

BOLT CARRIER ASSEMBLY EXPLODED DIAGRAM

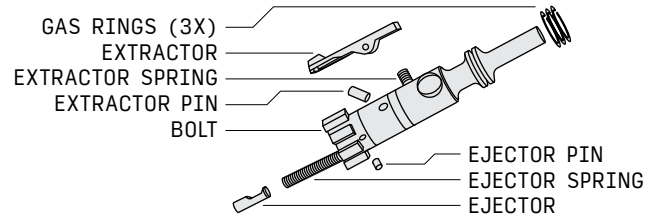
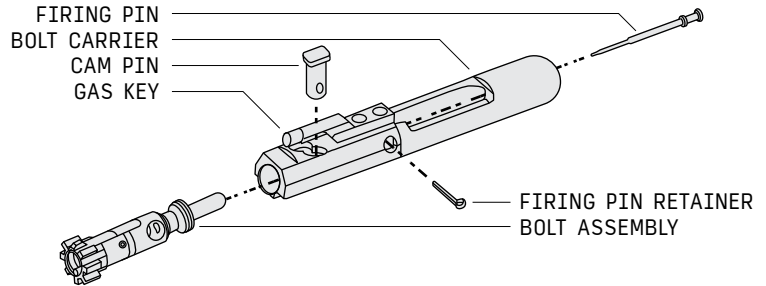

TROUBLESHOOTING

PROBLEM	CHECK FOR	WHAT TO DO
WON'T FIRE	<ul style="list-style-type: none">- Selector lever is in "SAFE" position.- Improper assembly of firing pin- Oil or fouling in bolt- Defective ammunition- Too much Carbon on firing pin- Bolt not fully locked	<ul style="list-style-type: none">- Put lever in "FIRE" position- Assemble correctly- Clean with pipe cleaner- Remove and discard- Clean- Extract cartridge, clear area
BOLT WON'T LOCK	<ul style="list-style-type: none">- Dirty bolt- Dirt, corrosion or carbon buildup in barrel locking lugs- Burred, cracked or broken bolt- Wrong ammunition	<ul style="list-style-type: none">- Clean- Clean- Contact Christensen Arms- Discard / replace
WON'T EXTRACT	<ul style="list-style-type: none">- Broken extractor spring- Inner spring or reinforcement ring missing from extractor spring- Dirty, corroded or reloaded ammunition- Carbon in chamber- Frozen- Worn extractor- Restricted buffer assembly- Restricted movement of bolt carrier assembly	<ul style="list-style-type: none">- Replace- Replace- Discard / replace- Clean chamber- Remove and clean- Remove and clean- Remove and clean- Remove, clean and lubricate

TROUBLESHOOTING (CONT)

PROBLEM	CHECK FOR	WHAT TO DO
BOLT FAILS TO LOCK OPEN AFTER LAST ROUND SELECTOR LEVER BINDS	<ul style="list-style-type: none">- Defective magazine- Defective magazine- Needs oil- Dirt or sand under trigger	<ul style="list-style-type: none">- Replace- Clean or replace- Lubricate- Clean
BOLT CARRIER "HUNG UP"	<ul style="list-style-type: none">- Round jammed between bolt and charging handle and / or double feed	<ul style="list-style-type: none">- Remove magazine- Keep muzzle away from you and bystanders- Push in on bottom of bolt catch- Gang firearm butt on ground, bolt should shift to rear- While bolt is held to rear, round should fall out through magazine well <p><i>NOTE: IF THIS PROCEDURE FAILS, USE A CLEANING ROD TO PUSH BOLT FULLY TO THE REAR THROUGH THE EJECTION PORT.</i></p>
WON'T EXTRACT	<ul style="list-style-type: none">- Clogged gas tube- Short recoil	<ul style="list-style-type: none">- Replace- See below

PROBLEM	CHECK FOR	WHAT TO DO
WON'T FEED	<ul style="list-style-type: none"> - Dirty, corroded or reloaded ammunition - Dirty or defective magazine - Too many rounds in magazine - Buffer assembly is restricted - Magazine not fully seated 	<ul style="list-style-type: none"> - Remove and discard - Clean and lubricate or replace - Remove excess rounds - Take out and clean buffer and spring - Adjust magazine catch: Press button right side, and turn catch on left. NOTE: Tightens clockwise
DOUBLE FEED	<ul style="list-style-type: none"> - Short recoil 	<ul style="list-style-type: none"> - See Below
WON'T CHAMBER	<ul style="list-style-type: none"> - Defective magazine - Dirty, corroded or defective ammunition - Ejector stuck - Carbon in carrier key or chamber 	<ul style="list-style-type: none"> - Replace - Remove and discard - Clean and oil - Clean
SHORT RECOIL	<ul style="list-style-type: none"> - Bolt ring worn or too loose - Carbon or dirt in carrier key or on outside of gas tube - Q-tip / pipe cleaner stuck inside carrier key - Loss of gas power - Weak or reloaded ammunition - Dirty firearm - Improper lubrication 	<ul style="list-style-type: none"> - Replace - Clean - Remove - Check entire gas path - Replace with factory fresh ammunition - Clean - Lubricate generously

WARRANTY AND GUARANTEE INFORMATION

WARRANTY

CHRISTENSEN ARMS warrants that the enclosed firearm was originally manufactured free of defects in material, workmanship and mechanical function. For the lifetime of the original purchaser, CHRISTENSEN ARMS agrees to correct any defect in the firearm for the original purchaser by repair, adjustment or replacement, at CHRISTENSEN ARMS' sole option, with the same or comparable quality components (or by replacing the firearms at CHRISTENSEN ARMS' option), subject to the limitations detailed below.

This limited warranty is null and void if the firearm has been misused; damaged (by accident or abuse); fired with improper ammunition; fired with an obstruction in the barrel; damaged through failure to provide reasonable and nec-

essary maintenance as described in the manual accompanying the firearm; or if unauthorized repair or any alteration, including of a cosmetic nature, has been performed on the firearm by a party other than CHRISTENSEN ARMS. This limited warranty does not apply to normal wear and tear of any parts.

Subject to the foregoing, this limited warranty confers the right to have the covered firearm or its parts repaired, adjusted or replaced exclusively upon the original purchaser, which right is not transferable to any other person.

No implied warranties of any kind are made herein and this warranty does not apply to any accessory items attached or appurtenant to the firearm.

In no event shall CHRISTENSEN ARMS be liable for any incidental or consequential damages arising from or in connection with this limited warranty.

GUARANTEE

This firearm is covered by a Sub-MOA accuracy guarantee. Customer is responsible to ensure proper break-in of the firearm during the warranty period, select appropriate ammunition, ensure proper lubrication and use proper conditions.

DISCLAIMER

Christensen Arms® delivers a firearm free of defects. Our guarantee requires that firearm owners safely handle, properly break in, and properly maintain the firearm. Improper use or owner modifications to the firearm voids the guarantee and warranty.

PRODUCT REGISTRATION

Thank you for choosing a Christensen Arms firearm. Years of dedication and innovation have led to this gun, and we hope you'll enjoy it as much as we do. For the most complete service and to stay up to date with our Christensen Arms owners program, please take the time to register your firearm with us:

WWW.CHRISTENSENARMS.COM/REGISTER





ADDRESS

550 N CEMETERY RD
GUNNISON, UT
84634

EMAIL

SALES@
CHRISTENSENARMS.COM

LOCAL

435.633.4667

FREE

888.517.8855

FAX

435.528.5773

