

REMINGTON FIELD SERVICE MANUAL

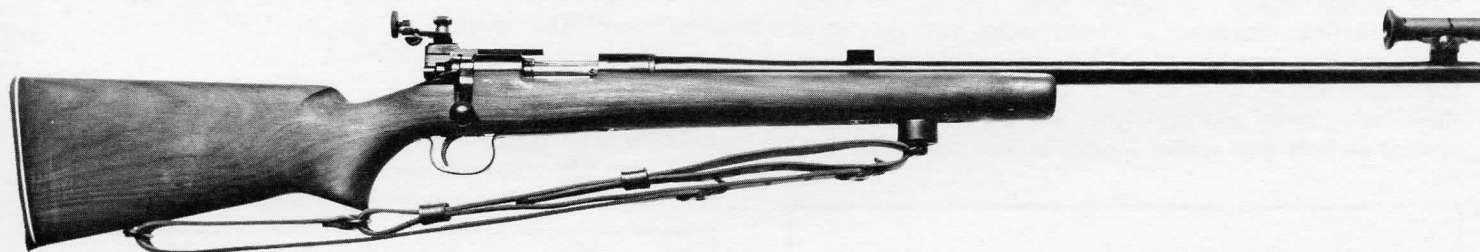

The Remington "Rangemaster" Model 40X is a bolt action 22 caliber match rifle. This rifle is of single shot solid frame design chambered for long rifle cartridge only. The gun action is hand operated and similar in function with most rifles of the bolt action type. Also included in this supplement is the Model 40XR. Unless otherwise specified, instructions are same as for the Model 40X.

INDEX

	Page		Page
Bolt Assembly	1	Sights	4
Bolt Assembly — Components	1	Adjust Trigger Pull.	4
Barrel Assembly	2	Malfunctions	4-6
Barrel Assembly — Action Group	3	Cycle of Operation	6
Trigger Assembly.	3	Exploded View	7
Stock, Stock Assembly.	3	Model 40XB Rim Fire	8
Stock Assembly — Components	3	Exploded View, 40XR	9
Bedding Escutcheon Assembly — Components	3	Parts List, 40 XR.	10

Send all guns for factory service and inquiries on service and parts to
REMINGTON ARMS COMPANY, INC.
 Arms Service Division
 Ilion, New York 13357

MODEL 40X

ASSEMBLY

Caution: Make certain no cartridge is in barrel before handling.

1. BOLT ASSEMBLY:

This assembly is designed to close and lock action securely to barrel breech against chambered round. The loading, firing and extracting mechanism is carried within this part. Push safety switch forward to "FIRE" position. (Bolt handle will not raise if safety switch is in rear or "ON SAFE" position.) Raise bolt handle and pull bolt assembly rearward. Press upward on bolt stop release located in front of trigger (See Fig. 1.).

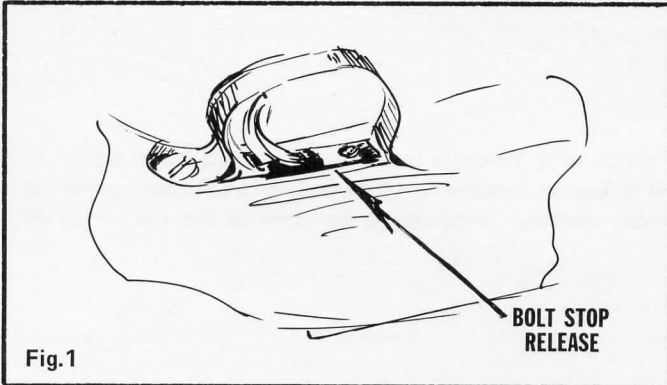

Continue pulling bolt assembly rearward and disassemble from receiver of rifle. The bolt assembly is factory listed to include bolt body assembly, firing pin assembly, bolt head, bolt pin (2), extractor, left; extractor, right; extractor plunger (2), extractor spring (2).

NOTE: Normal removal of bolt assembly from rifle will retract or draw back firing pin. The firing pin head, pinned to rear of firing pin will then hold firing pin in a retracted position. The bolt assembly **can not be replaced** to rifle unless firing pin is in the retracted position. (See Fig. 2).

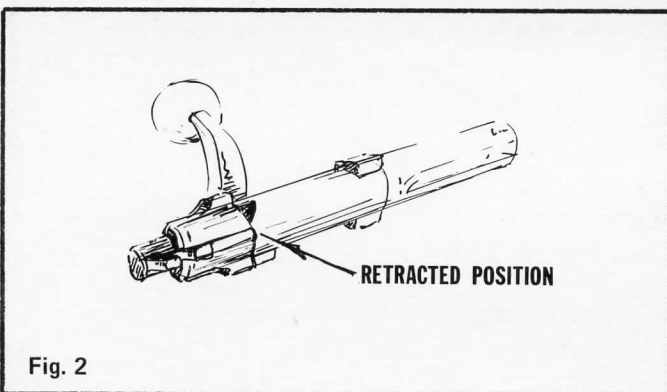

If firing pin has been released forward for some reason with the bolt assembly removed from the rifle, it may be retracted in the following manner: Hold flat under section of firing pin head **tightly in a vise jaw**. Raise bolt handle upward. This movement of handle will cam bolt body forward and permit retraction of firing pin to a notched position on rear under rim of body assembly.

IMPORTANT: Bolt assemblies are numbered on under surface to match rifle number. Close headspace and firing pin

indent measurement limits require precision assembly of bolt assembly components. Therefore, any replacement of bolt assembly requires careful assembly to maintain proper headspace and firing pin requirements.

2. BOLT ASSEMBLY – COMPONENTS: (With bolt assembly removed from rifle)

FIRING PIN ASSEMBLY – is designed as a spring powered striker to indent cartridge primer and explode round. To disassemble from bolt assembly, pull back or retract firing pin head from bolt plug until coin or similar flat tool can be wedged between firing pin head and bolt plug. (See Fig. 3).

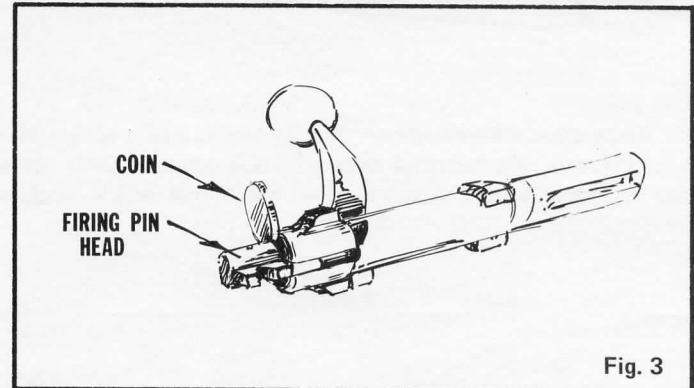

Hold firing pin head in this retracted position and unscrew bolt plug from bolt body assembly. Pull out and disassemble firing pin assembly from bolt body assembly-bolt head. Bolt head will revolve when firing pin is withdrawn. **NOTE:** The firing pin assembly is factory listed to include bolt plug, firing pin, firing pin cross pin, firing pin head, main spring. Reassemble in reverse order. Take care that firing pin aligns properly in hole in front of bolt head.

FIRING PIN ASSEMBLY – COMPONENTS (with assembly disassembled from bolt assembly)

Firing Pin Head – is designed to retract firing pin and notched to hold "cocked" against upthrust sear. To disassemble, pull back and hold firing pin head against compressed main spring.

Drive out firing pin cross pin-visible in side of retracted firing pin head. Disassemble tightly fitted firing pin head from rear shank of firing pin. Release pressure on retracted main spring.

Bolt Plug – is designed to hold firing pin assembly properly assembled to bolt assembly.

MAIN SPRING

FIRING PIN

All of the above listed components of firing pin assembly will be freed as firing pin head is disassembled, and can be separated. (See Fig. 4).

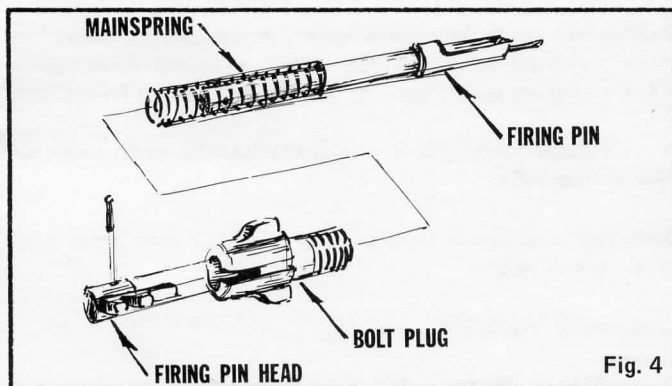

Fig. 4

Reassemble in reverse order — with **Firing Pin Head** holding all components assembled as a firing pin assembly. **IMPORTANT:** A replacement firing pin must be **Free Fitting** within bolt assembly and correct protrusion limits (Maximum .036" — Minimum .031") maintained to produce proper indent on the round. The firing pin is factory listed to include three (3) components; firing pin point, firing pin body and firing pin shank. All three components are copper brazed under rigidly controlled factory processes for proper assembly. Factory replacement as a unit is recommended.

Bolt Body Assembly — is designed as the middle section of bolt assembly to provide the opposed locking lugs, and handle to operate bolt action.

(With firing pin assembly removed) Drive bolt pin (2) from locking lugs (2) on bolt body assembly. Pull away and disassemble bolt body assembly from bolt head. See Fig.5).

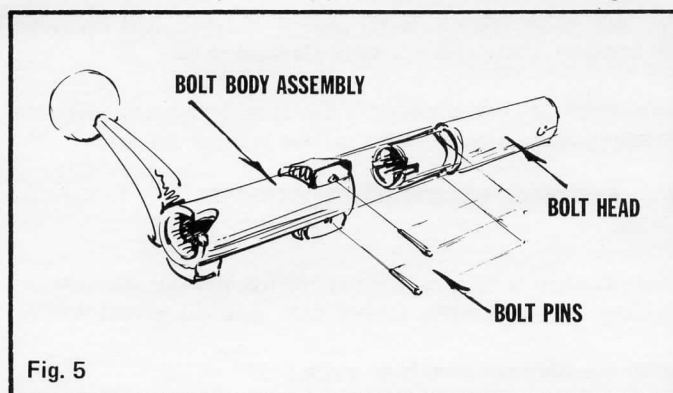

Fig. 5

The bolt body assembly includes bolt body and bolt handle. The components are riveted and copper brazed under rigidly controlled factory processes to form the assembly. Replacement as an assembly is recommended.

Reassemble in reverse order.

Bolt Head — is designed as the front section of bolt assembly to breach up chambered round to barrel and contain the opposing extractors which grip the rim and guide extracting and ejecting round.

Bolt Head — will be free and can be disassembled from bolt assembly when bolt body assembly is disassembled (See **Bolt Body Assembly**). **IMPORTANT:** Replacement of bolt requires careful breeching to meet proper headspace limitations between face of the closed and locked bolt and chamber rim (.042" to .045"). See Fig 6.

Protrusion of firing pin to established limits, (.031" to .036") for proper indent on the primer of the chambered round, must also be checked when a bolt head is replaced (See **Firing Pin**).

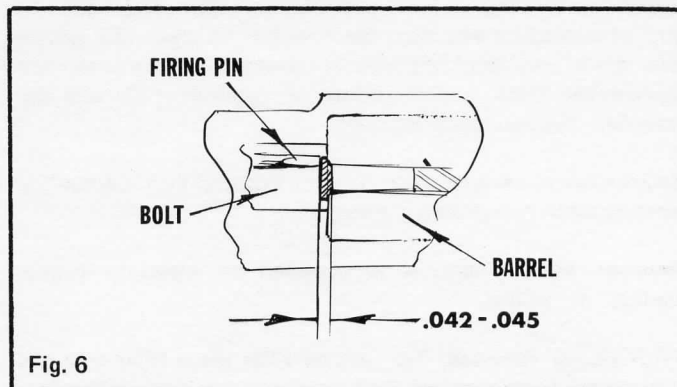

Fig. 6

Reassemble bolt head to bolt body assembly in reverse order.

Extractor, Right and Left — are designed to extract and assist in the ejection of fired or unfired round. Force extractor plunger rearward in bolt head and away from rear shoulder of extractor. Pry up and raise rear of extractor from bolt head.

NOTE: The shape of extractor, right, is more claw like than extractor, left. Extractor, left, is shaped to maintain tension against the opposing grip of this clawlike extractor, right.

Reassemble extractors in order. Replacement extractor may require a tightening adjustment for proper tension against round. Carefully remove steel from middle pad of right extractor. See Fig. 7.

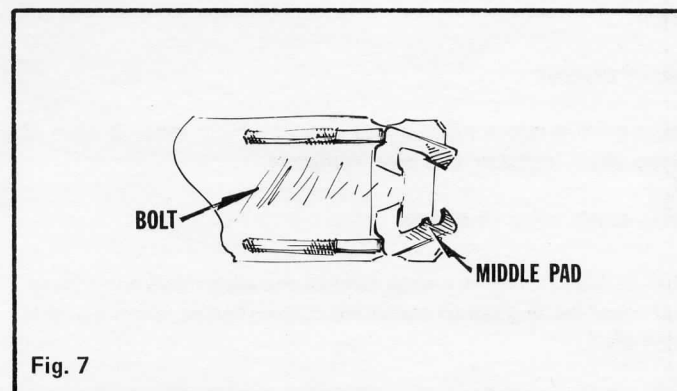

Fig. 7

3. BARREL ASSEMBLY (With trigger assembly attached)

This basic model assembly is factory listed to include only the barrel, barrel bracket and receiver.

Trigger Guard — Unscrew all three (3) guard screws; rear, middle and front. Disassemble from stock. Lift loosened trigger guard and disassemble from stock. Disassemble loosened barrel assembly from stock assembly. **NOTE:** The **Trigger Guide Plate** underlies trigger guard in stock and can be lifted freely from position after trigger guard is removed.

Reassemble in reverse order. **NOTE:** Settle barrel bracket well back against recoil slot in stock and tighten front guard screw first. Replacement barrel assembly may require rebedding to "float" free of wood contact.

MODEL 40X

4. BARREL ASSEMBLY — ACTION GROUP (With bolt and stock assemblies removed)

Ejector — is designed to trip the extracting round from the grip of extractors and eject the round from port. The ejector also serves as a loading platform. Unscrew ejector screw and disassemble from under surface of receiver. Lift and disassemble ejector from receiver.

Reassemble in reverse order. NOTE: Position bolt "closed" in receiver when reassembling ejector.

Receiver Filler Piece — is designed to assist in proper loading of round.

(With ejector removed) Tip receiver filler piece from rear and disassemble from receiver. Dislocate and disassemble **Receiver Filler Spring** from inner side of receiver filler piece, if desired.

Reassemble in reverse order

Trigger Assembly

NOTE: FACTORY SERVICE IS REQUIRED FOR ALL TRIGGER ASSEMBLY RELATED PROBLEMS. RETURN THE FIREARM TO THE FACTORY FOR SERVICE.

Barrel — Receiver — is screwed very tightly to the barrel. IMPORTANT: Any replacement of barrel or receiver requires correct head spacing to the barrel and face of closed bolt. Proper alignment of barrel bracket is required. Unscrew receiver and disassemble from barrel. NOTE: Close fitting holding jaws should be used to prevent damage to barrel or receiver.

Barrel Bracket

Slip barrel bracket rearward and disassemble from breech of barrel after receiver has been removed.

Reassemble parts in reverse order.

IMPORTANT: The extractor cuts of the assembled and closed bolt must be aligned to matching cuts in barrel, when barrel is assembled.

Headspace — limits between face of closed bolt and cartridge rim cut of barrel chamber are listed as .045" max. — .042" min. (See Fig. 6).

5 STOCK — STOCK ASSEMBLY

Unscrew and disassemble all three guard screws, rear middle and front. Disassemble loosened trigger guard from stock. Remove stock from barrel and action. Remove trigger guide plate which underlays the trigger guard.

The stock is factory listed to include the stock, butt pad and butt pad screw (2). Also supplied, is an alternate replacement unit, the "STOCK ASSEMBLY". This unit is factory listed to include the stock, butt pad, butt pad screw (2), bedding escutcheon assembly (2), front swivel assembly and front swivel base screw (2). NOTE: The stock alone without butt pad or screws is not supplied.

Reassemble stock in reverse order. Barrel should "float" in stock and have approximately .010" clearance from wood. When replacing stock, specify **Standard** or **Heavy** barrel type

6 STOCK ASSEMBLY — COMPONENTS (with stock removed from rifle).

Butt Pad - Unscrew butt pad by reaching into open hole (2) in rear of pad.

Disassemble butt pad from stock.

Reassemble in reverse order. Replacement of butt pads should show tight fit and slight rubber rather than wood margin.

Front Swivel Assembly - is designed to adjust and hold the position of shooting sling.

Unscrew **Front Swivel Screw** and disassemble **Front Swivel Front Swivel Bushing, Front Swivel Block, Front Swivel Washer** from front swivel base in stock.

Reassemble to front swivel assembly in reverse order.

Front Swivel Base

Unscrew front swivel base screw (2) and disassemble base and **front swivel nut** from stock. Use care to prevent wood split as nut is tightly fitted. Reassemble in reverse order.

Bedding Escutcheon Assembly

Tap out drive toward barrel groove in stock, and disassemble bedding escutcheon assembly (2) from stock.

Reassemble in reverse manner making sure that large diameter of assembly seats below wood surface in barrel groove.

7 BEDDING ESCUTCHEON ASSEMBLY — COMPONENTS.

This assembly is factory listed to include bedding escutcheon, bedding screw, bedding detent ball, bedding detent spring,

(With assembly removed from stock.)

Unscrew bedding screw from bedding escutcheon part way until **Bedding Ball** can be disassembled from a spring tensed position against the knurl of the bedding screw. Use care to prevent losing bedding ball when bedding screw is backed out of bedding escutcheon. Bedding screw can then be unscrewed completely from bedding escutcheon and disassembled from escutcheon. **Bedding detent spring** can be picked from recess in thread of bedding escutcheon after bedding screw and bedding screw and bedding detent ball have been disassembled.

Reassemble in reverse order. When reassembling bedding detent ball, hold down against spring until bedding screw will cover same. Use small drill or rod against ball from small hole opposite, in large diameter of escutcheon. Bedding screw should be returned flush or below surface of large diameter on bedding escutcheon.

8 SIGHTS

Standard Barrel S2 — is furnished without sights. However, sighting equipment on the S2 includes telescope base, front; telescope base, rear; telescope base screw (4). Receiver plug screw (6) also included. Two are screwed into position near muzzle of barrel; four are screwed to receiver, two on left rear of receiver and two on top front of receiver.

Heavy Barrel H2 — is also furnished without sights. Sighting equipment on the H2 includes same as S2 except a shorter height telescope base, front, is used to keep same receiver alignment. This, of course, means a shorter telescope base screw is used.

Standard Barrel S1 — is furnished with Redfield Olympic sights; Redfield front sight No. 1 with ten (10) inserts or sighting apertures, and Redfield receiver sight. Both Redfield sights have their own bases that replace receiver plug screws, at muzzle and rear left side of receiver. Both sights may be disassembled from their respective base. For shipment, new guns from factory are packaged with Redfield sights dismounted from their base on rifle.

Heavy Barrel H1 — is also furnished with Redfield Olympic sights identical with type on the S1 except for variation in height to keep the same sight line at receiver.

Telescope Bases — are furnished on all model types, **standard** or **heavy** barrel, and **with** or **without** Redfield sights.

The rear telescope base is assembled to rear position on receiver when rifle is shipped. This rear position arrangement for "wide base" location of telescope, requires six (6) adjusting clicks of telescope to change center of impact one inch on the 100 yard target.

With rear telescope base moved to front, "close base" position on receiver, four (4) adjusting clicks are required to change center of impact one inch on the 100 yard target.

TO ADJUST TRIGGER PULL

Adjustment for the trigger pull is made by turning the trigger screw, front. See Fig. 8. Turn trigger screw front clockwise to adjust for a heavier pull and counterclockwise for a lighter pull.

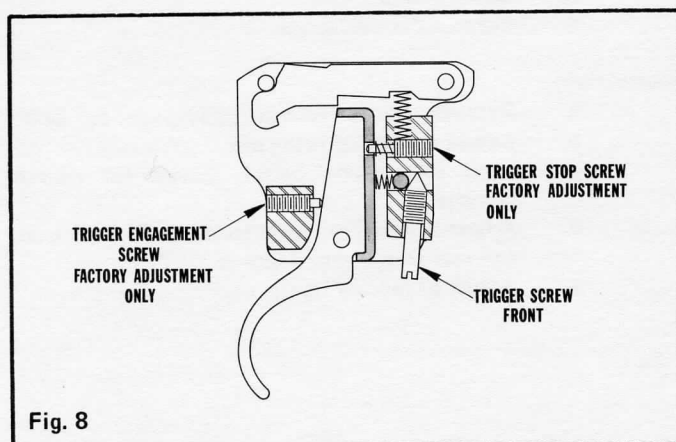

Fig. 8

WARNING: THE WEIGHT OF THE TRIGGER PULL ON THIS TARGET RIFLE MUST NEVER BE ADJUSTED BELOW TWO (2) POUNDS.

NOTE: AFTER ADJUSTING THE TRIGGER PULL, PUT THE SAFETY SWITCH IN THE "F" POSITION. CLOSE THE BOLT SMARTLY. FIRING PIN MUST REMAIN COCKED (DRY FIRE TO CHECK). REPEAT TEST AT LEAST TEN (10) TIMES. IF FIRING PIN WILL NOT REMAIN COCKED, TRIGGER PULL IS ADJUSTED TOO LIGHT, READJUST TRIGGER SCREW FRONT OR RETURN FIREARM TO THE FACTORY.

MALFUNCTIONS

Cause and Correction

BOLT FAILS TO ASSEMBLE**Cause:**

- Bolt uncocked.
- Bolt stop damaged.
- Bolt head rotated slightly out of position.
- Receiver filler piece binds bolt.

Correction:

- Cock bolt. See **BOLT ASSEMBLY**.
- Return firearm to the factory.
- Reposition bolt head radially.
- Depress receiver filler piece into receiver.

BOLT CLOSSES HARD**Cause:**

- Rough chamber.
- Rough cam in receiver.
- Bolt lugs damaged.
- Too little headspace. (.042" Min., .045" Max.)
- Extractor cut in barrel damaged.

Correction:

- Repolish (lightly) or replace barrel.
- Smooth up cam or replace receiver.
- Smooth up bolt lugs or replace bolt body assembly.
- Adjust headspace or replace barrel.
- Clear up damage or replace barrel.

BOLT FOLLOWS DOWN (Uncocks)**Cause:**

- Engagement of sear to connector lacking or insufficient to hold.
- Trigger fails to retract.
- Sear damaged.
- Connector damaged.
- Sear and connector sticky.

Correction:

- Return firearm to the factory.
- Return firearm to the factory.
- Return firearm to the factory.
- Return firearm to the factory.
- Return firearm to the factory.

MODEL 40X

BOLT MISFIRES

Cause:

- a. Firing pin short, damaged.
- b. Firing pin binds in bolt assembly - light firing pin blow.
- c. Trigger assembly faulty.
- d. Main spring damaged.
- e. Ammunition faulty.

Correction:

- a. Replace firing pin-check protrusion carefully.
- b. Free up travel of firing pin or replace. Clean components.
- c. Return firearm to the factory.
- d. Replace main spring.
- e. Discard ammunition.

BOLT FAILS TO EXTRACT

NOTE: Make certain safety switch is in forward or "FIRE" position. Bolt handle will lock down in rear or "ON SAFE" position.

Cause:

- a. Extractor (right) damaged or missing.
- b. Extractor (right) grip on cartridge faulty.
- c. Extractor slots in barrel damaged shallow.
- d. Rough or damaged chamber.
- e. Fired cartridge bulged at base.

Correction:

- a. Replace extractor, right.
- b. Adjust hook space on cartridge. Remove some metal from middle pad on extractor. Check extractor plunger and spring.
- c. Repair extractor slots or replace barrel.
- d. Repolish chamber — use caution. Do not exceed chamber dimensions.
- e. Check headspace or replace barrel.

BOLT OPENS HARD

Cause:

- a. Extraction faulty.
- b. Extraction cam on base of bolt handle damaged.
- c. Filler piece damaged, defective.
- d. Trigger guard screws protrude into bolt track.
- e. Telescope base screws protrude into bolt track.
- f. Wood interferes with bolt handle.

Correction:

- a. See **FAILS TO EXTRACT**.
- b. Repair or replace bolt body assembly.
- c. Adjust or replace filler piece.
- d. Shorten length of guard screw.
- e. Shorten length of telescope base screw.
- f. Provide proper clearance for bolt handle.

BOLT FAILS TO EJECT

Cause:

- a. Ejector (loading platform) damaged, loose.
- b. Cartridge loose under extractors.
- c. Extraction faulty.

Correction:

- a. Replace or tighten ejector.
- b. Adjust grip of extractors to cartridge. Check retraction of firing pin.
- c. See **FAILS TO EXTRACT**.

BOLT PULLS OUT

Cause:

- a. Bolt stop damaged.
- b. Bolt stop release damaged.
- c. Bolt stop binds down.

Correction:

- a. Return firearm to the factory.
- b. Return firearm to the factory.
- c. Return firearm to the factory.

SAFETY FAILS

Cause:

- a. Safety switch binds.
- b. Safety switch loose.
- c. Safety switch damaged.

Correction:

- a. Return firearm to the factory.
- b. Return firearm to the factory.
- c. Return firearm to the factory.

TARGET - GROUP FAULT

Cause:

- a. Cartridge chamber worn long, defective.
- b. Firing pin indent faulty.
- c. Barrel bore or muzzle damaged.
- d. Barrel bedding faulty.
- e. Sights defective, loose.

Correction:

- a. Replace barrel (check headspace to bolt).
- b. Adjust or replace firing pin.
- c. Lead or replace barrel. Check for muzzle damage.
- d. Adjust bedding or barrel to stock. Tighten front and rear trigger guard screws.
- e. Adjust or replace sights.

TARGET – CENTER OF IMPACT FAULTY**Cause:**

- a. Barrel crooked.
- b. Barrel bore or muzzle damaged.
- c. Sights faulty.

Correction:

- a. Replace or straighten barrel. **IMPORTANT:** (Check headspace to bolt, if replacing).
- b. Replace barrel, lead bore, repair or recrown muzzle.
- c. Adjust or replace sights.

CYCLE OF OPERATION

The Model 40X is a bolt action, single shot rifle of MATCH design. The operation of the bolt is fully controlled by the shooter to perform the basic functions. The Cycle of Operations controlling these basic functions is similar in many respects to the Model 721-722. In detail, the movement of the components for each basic function is as follows:

FIRING

The firing cycle is simply the release of a spring-loaded firing pin. The forward thrust of this spring-urged pin strikes rim of a fully chambered cartridge with sufficient force to explode priming mix and thus ignite powder charge. This release is made possible in the following manner. With the thumb operated safety switch rotated to forward or "FIRE" position trigger may be pulled. This pivots top portion of trigger about its pin and carries a trigger connector forward. This connector, fitted atop trigger, supports sear and this trigger movement deprives sear of its support, permitting it to be cammed downward and over-ridden by firing pin. The use of a connector rather than the trigger itself to "block up" sear is to provide, on firing, sufficient clearance for free sear movement while limiting trigger movement and permitting no trigger over-travel.

UNLOCK:

After firing, and upward swing of bolt handle rotates rear portion of bolt and unseats the locking lugs of bolt from their supporting shoulders in receiver. The bolt is then free to be drawn rearward.

COCK:

The cocking of rifle is done without any conscious effort by the shooter during cycle of operation. The cocking is partially accomplished during unlocking cycle. As bolt handle is lifted, a cam on rear of bolt retracts firing pin to a partial cock position on the rear perimeter of the bolt. The cocking is completed during locking cycle.

EXTRACTION:

The head of cartridge is seated within bolt face with its rim gripped by claws of the two opposed extractors. As bolt handle completes its upward swing, when unlocking, a primary extracting cam on receiver retracts bolt approximately one-

eighth of an inch. When bolt handle has been raised completely, locking lugs of bolt are turned free of supporting shoulders in receiver and bolt can be drawn rearward to complete extraction.

EJECTION:

As fired cartridge case is extracted from chamber, left corner at rear of ejector groove trips case from grip of extractors. The case is then flipped from rifle as bolt continues past ejector to its rearward position against bolt stop.

FEEDING

With action completely open, a cartridge to be loaded may be placed on groove of ejector. The initial return movement of bolt then will engage base of this cartridge and slide cartridge up this groove towards chamber.

LOADING:

As bolt continues forward, cartridge is pushed into chamber.

LOCKING

With breech closed and a cartridge fully loaded into chamber, final movement of the bolt handle downward rotates and locks bolt head against cartridge. During this rotary locking motion, three engagements are made: The two locking lugs at mid-section of the two piece bolt are seated against receiver; the two extractors are flexed and snap over rim of cartridge; and sear engages firing pin head, thus holding firing pin in a fully cocked position as bolt cams away, and slightly forward, during downward swing of bolt handle to lock breech. (The sear then is firmly notched upward against firing pin head by trigger connector until rifle is fired. See firing cycle.)

SAFETY SWITCH

The thumb-operated safety switch, located at right rear of receiver operates the same as Model 721-722. In the **SAFE** or rear position, the firing pin cannot be released, nor can bolt handle be raised. In the **FIRE** or forward position, the rifle can be fired or bolt handle raised. The simplified directions for operation and normal maintenance of this rifle are contained in the instruction Folder packaged with each rifle.

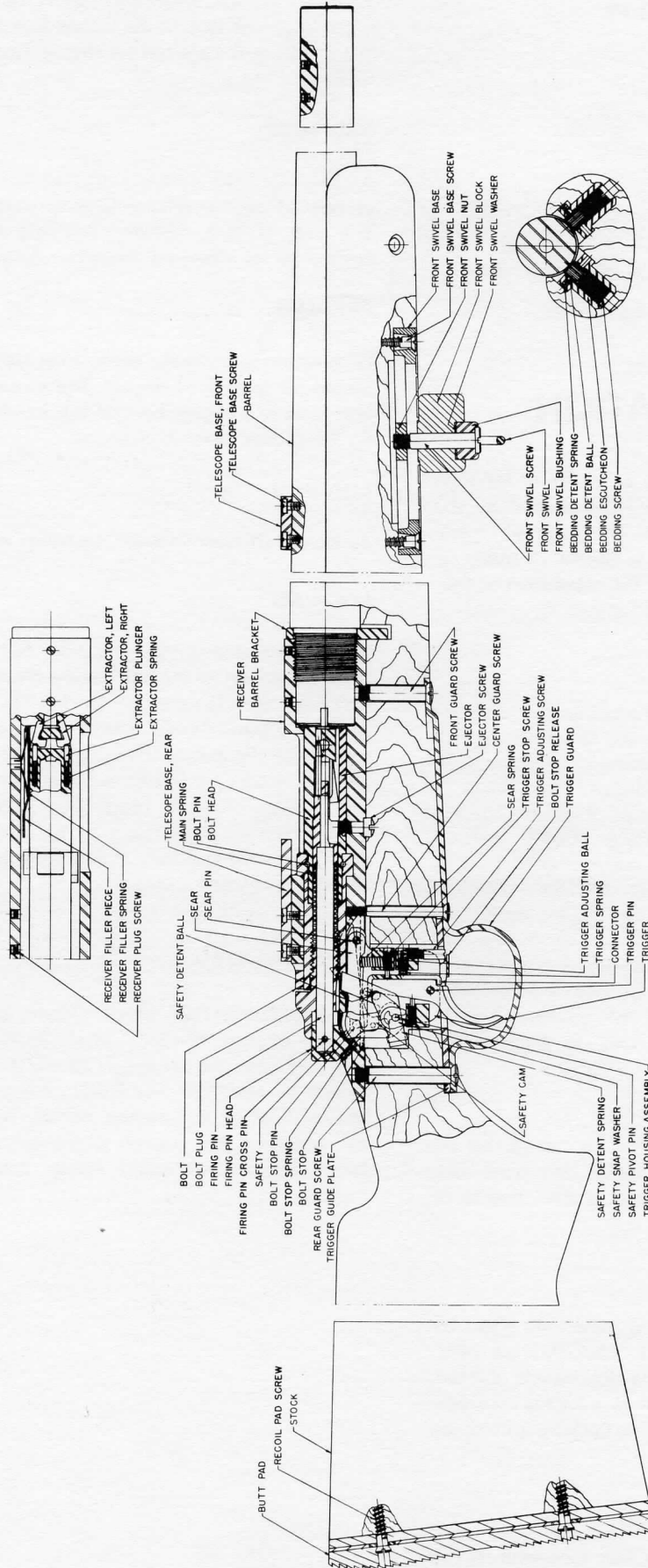

REMINGTON FIELD SERVICE MANUAL

This service supplement for the Model 40—XB will include only those parts that are different from Model 40—X. See Model 40—X (or 40—XB center fire) for parts not listed herein. Note also reference to existing assembly instructions as required.

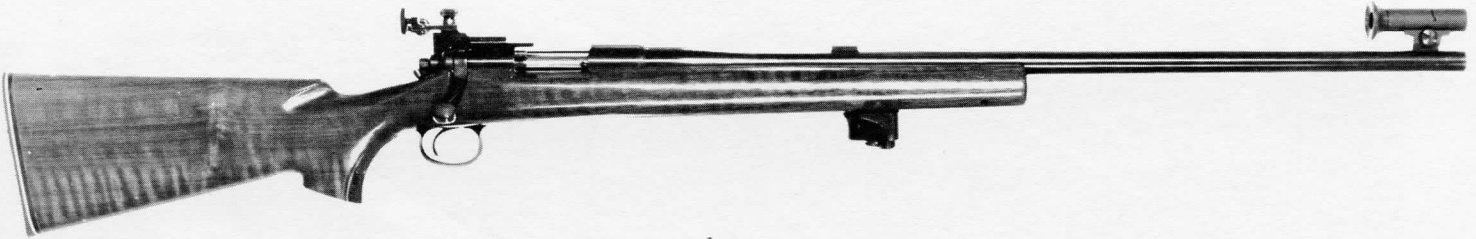

SAFETY SWITCH - features a 2-position design to rear of bolt handle. A corrugated non-slip thumbpiece can be rotated to rear for **ON SAFE** stop position and rotated forward to **FIRE** stop position. See Model 40-XB Center Fire Manual for assembly instructions.

BOLT ASSEMBLY — introduced as "swept-back" handle design, similar to Model 700. See Model 40—X Manual for 22 Caliber "two piece" design.

FRONT SWIVEL ASSEMBLY

Rim fire — 22 Caliber — includes fore end rail, front rail screw (2), rear rail screw (2), front swivel, front swivel block, front swivel washer (2), front swivel bushing, front swivel screw, front swivel nut.

FORE END RAIL — is a long channel design for full length adjustment of front swivel block.

To Disassemble — Unscrew and remove four (4) rail screws at front and rear. Front guard screw (1) must also be removed. Lift out and disassemble loosened fore end rail from stock. Note: Front swivel block (and fittings) may remain attached to rail.

To Reassemble — Position fore end rail (or front swivel base) to stock and assemble rail (or base) screws.
Note: When reassembling rail make certain front guard screw tightens securely to receiver.

FRONT SWIVEL BLOCK — is designed for strap adjustment in any forward position. Turn swivel screw to loosen block for adjustment.

To Disassemble — Unscrew front swivel screw and disassemble all parts of the front swivel assembly from fore end rail.

To Reassemble — Position all parts in proper order and assemble front swivel screw to front swivel nut. Tighten front swivel block to fore end rail.

TRIGGER GUARD — is of light weight short design, to rear of the long fore end rail.

To Disassemble — Unscrew and remove both rear and middle guard screws. Pull out guard and disassemble from stock.

To Reassemble — Locate properly over trigger and into stock. Assemble both screws and tighten guard securely to receiver.

REMINGTON FIELD SERVICE MANUAL

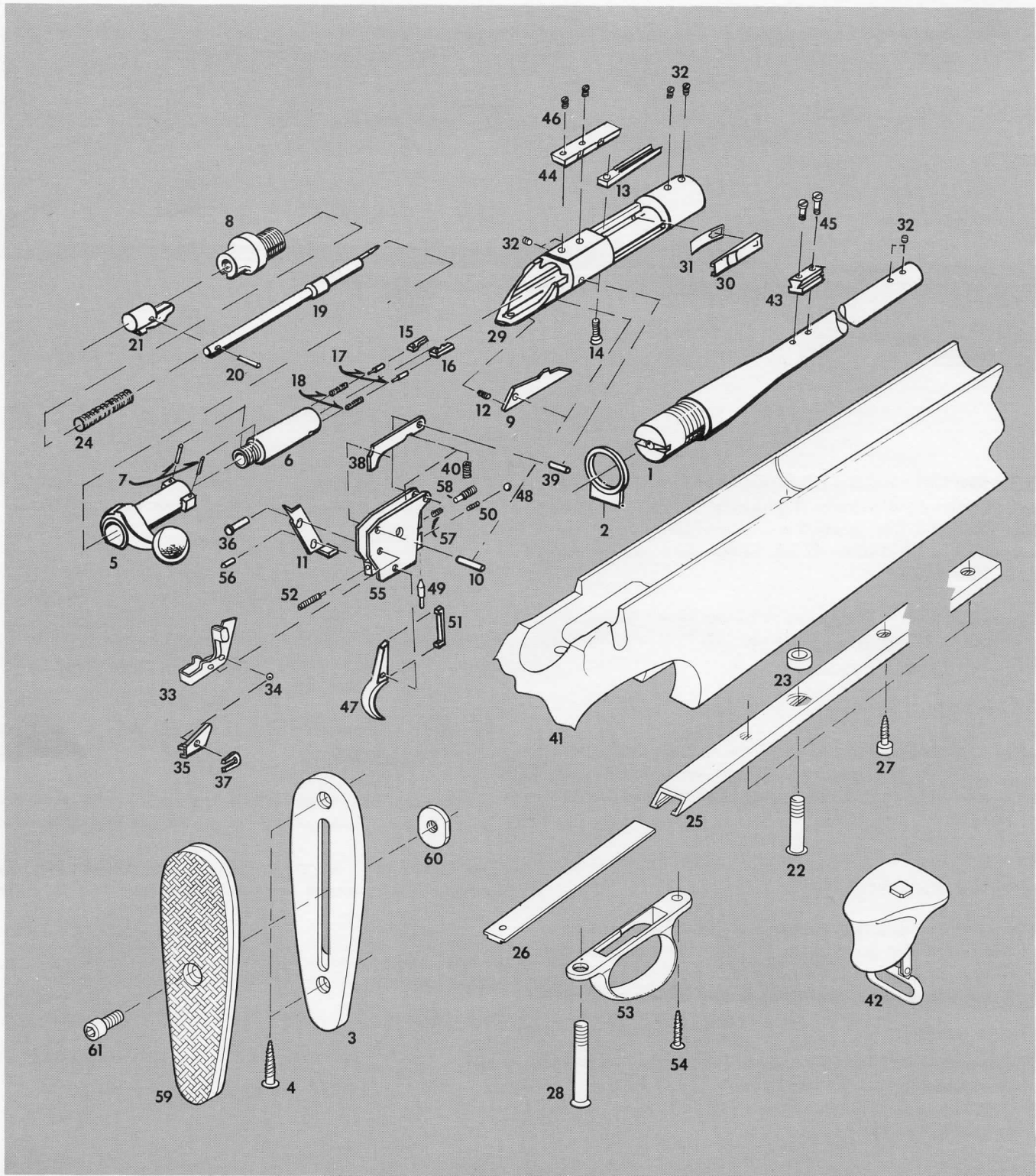

REMINGTON FIELD SERVICE MANUAL

View No.	NAME OF PART	View No.	NAME OF PART
1	Barrel (Restricted)	55	Trigger Housing Assembly (Restricted)
2	Barrel Bracket	56	Trigger Pin (Restricted)
3	Base Plate	57	Trigger Spring (Restricted)
4	Base Plate Screw	58	Trigger Stop Screw (Restricted)
5	Bolt Body Assembly (Restricted)	59	Vertical Adjusting Plate Assembly
6	Bolt Head (Restricted)	60	Vertical Adjusting Plate Locknut
7	Bolt Pin (Restricted)	61	Vertical Adjusting Plate Lockscrew
8	Bolt Plug (Restricted)		Butt Plate Assembly Complete
9	Bolt Stop (Restricted)		
10	Bolt Stop Pin (Restricted)		
11	Bolt Stop Release (Restricted)		
12	Bolt Stop Spring (Restricted)		
13	Ejector		
14	Ejector Screw		
15	Extractor Left		
16	Extractor Right		
17	Extractor Plunger		
18	Extractor Spring		
19	Firing Pin		
20	Firing Pin Cross Pin		
21	Firing Pin Head		
22	Front Takedown Screw		
23	Front Takedown Screw Bushing		
24	Main Spring		
	Rail		
26	Rail Insert		
27	Rail Screw		
28	Rear Guard Screw		
29	Receiver (Restricted)		
30	Receiver Filler Piece		
31	Receiver Filler Spring		
32	Receiver Plug Screw		
33	Safety Switch Assembly (Restricted)		
34	Safety Switch Detent Ball (Restricted)		
35	Safety Switch Detent Spring (Restricted)		
36	Safety Switch Pivot Pin (Restricted)		
37	Safety Switch Snap Washer (Restricted)		
38	Sear Safety Cam (Restricted)		
39	Sear Pin (Restricted)		
40	Sear Spring (Restricted)		
41	Stock Assembly		
42	Swivel Block		
43	Telescope Base Front		
44	Telescope Base Rear		
45	Telescope Base Screw Front		
46	Telescope Base Screw Rear		
47	Trigger (Restricted)		
	Trigger Assembly Complete (Restricted)		
48	Trigger Ball Front (Restricted)		
49	Trigger Screw Front (Restricted)		
50	Trigger Spring Front (Restricted)		
51	Trigger Connector (Restricted)		
52	Trigger Engagement Screw (Restricted)		
53	Trigger Guard		
54	Trigger Guard Screw Front		