



LANTAC
RAVEN™
OPERATORS MANUAL

INSTRUCTIONS FOR OPERATION, MAINTENANCE & SAFETY PROCEDURE

INDEX

PRECAUTIONS	01
SAFE HANDLING	02
OPERATING SAFETY	03
RIFLE FEATURES	04
CLEARING	05
SAFETY CHECKS	06
OPERATION	07
ABS™ BUFFER SYSTEM	09
FIRING	10
FAILURE RECOVERY/ REMEDIAL ACTIONS	11
DISASSEMBLY	13
INSPECTION, CLEANING & LUBRICATION	17
REASSEMBLY	20
RETURNS & WARRANTY	22
PARTS INFORMATION	23
RECEIVER ASSEMBLIES	27
RIFLE RECORD SHEET	28

PRECAUTIONS

CAUTION

CAREFULLY READ AND UNDERSTAND THE FOLLOWING PRECAUTIONS BEFORE REMOVING THIS FIREARM FROM ITS PACKAGING. CAREFULLY READ AND UNDERSTAND THESE INSTRUCTIONS PRIOR TO LOADING AND FIRING THIS FIREARM. FOLLOW ALL INSTRUCTIONS ON THE PROPER HANDLING AND SAFE USE OF THIS FIREARM.

YOUR SAFETY AND THE SAFETY OF OTHERS DEPENDS ON YOUR UNDERSTANDING AND COMPLIANCE WITH SAFE HANDLING PRACTICES. IF YOU ARE UNFAMILIAR WITH FIREARMS AND THEIR OPERATION YOU SHOULD SEEK ADVICE AND TRAINING FROM YOUR LOCAL GUN CLUB OR AN NRA CERTIFIED INSTRUCTOR. FIREARMS SAFETY IS YOUR RESPONSIBILITY, ALWAYS PRACTICE SAFE FIREARMS HANDLING!

CAUTION

USE ONLY CLEAN, DRY, ORIGINAL, HIGH QUALITY COMMERCIALY MANUFACTURED AMMUNITION IN GOOD CONDITION WHICH IS APPROPRIATE TO THE CALIBER OF YOUR FIREARM.

LANTAC USA LLC DOES NOT RECOMMEND THE USE OF REMANUFACTURED OR HAND LOADED AMMUNITION. DO NOT USE STEEL CASED AMMUNITION.

ATTENTION

PLEASE OBSERVE THE CALIBER IDENTIFICATION LABEL ON THE END OF THE SHIPPING BOX. ONLY USE AMMUNITION OF THE CALIBER LISTED.

YOUR 14.5" INTERMEDIATE OR MIDLENGTH RAVEN™ RIFLE IS CHAMBERED IN .223 WYLDE AND CAN SAFELY FIRE AMMUNITION IN EITHER .223 OR 5.56X45 CALIBER. NO OTHER CALIBER AMMUNITION IS TO BE USED WITH THIS FIREARM.

WARNING

IF THIS FIREARM IS CARELESSLY OR IMPROPERLY HANDLED, UNINTENTIONAL DISCHARGE COULD RESULT AND COULD CAUSE INJURY, DEATH, OR DAMAGE TO PROPERTY.

WARNING

EYE PROTECTION MUST BE WORN AT ALL TIMES WHEN ASSEMBLING, DISASSEMBLING, CLEANING OR OPERATING THIS FIREARM.

WARNING

HEARING PROTECTION MUST BE WORN AT ALL TIMES WHEN OPERATING THIS FIREARM.

ATTENTION

LANTAC USA LLC CANNOT BE HELD RESPONSIBLE FOR INJURY, DEATH OR DAMAGE TO PROPERTY RESULTING FROM IMPROPER USE, ACCIDENTAL OR INTENTIONAL DISCHARGE OF THIS FIREARM OR FUNCTION WHEN USED FOR PURPOSES FOR WHICH IT WAS NOT DESIGNED OR INTENDED TO BE USED.

ALL WARRANTY CLAIMS ARE VALID FOR 'FIRST OWNER' OF THIS FIREARM ONLY, ANY CLAIMS FROM SECOND OR SUBSEQUENT OWNERS WILL NOT BE HONORED.

SAFE HANDLING

ATTENTION

YOU MUST FOLLOW THESE SAFETY INSTRUCTIONS FOR YOUR SAFETY AND THE SAFETY OF OTHERS AROUND YOU.

ALWAYS ASSUME THE FIREARM IS LOADED AND KEEP IT POINTED IN A SAFE DIRECTION. NEVER LOAD THE FIREARM UNTIL READY TO SHOOT. ALWAYS KEEP THE SAFETY SELECTOR IN THE 'SAFE' POSITION WHEN THE HAMMER IS COCKED AND KEEP YOUR FINGER OFF THE TRIGGER UNTIL YOU ARE READY TO SHOOT. ALWAYS BE SURE OF YOUR TARGET & WHAT IS BEYOND YOUR TARGET. NEVER SHOOT UNLESS YOU HAVE A SAFE BACKSTOP.

WARNING

THE RIFLE MAY FIRE IF THE TRIGGER IS PULLED AND THE SAFETY SELECTOR IS NOT FULLY IN THE 'SAFE' POSITION.

WARNING

THIS FIREARM COULD CHAMBER A ROUND IF IT IS DROPPED OR JARRED WITH A LOADED MAGAZINE APPLIED, EITHER WITH THE BOLT ASSEMBLY LOCKED TO THE REAR OR IN ITS FORWARD POSITION.

CAUTION

ALWAYS CARRY YOUR FIREARM EMPTY WITH THE BOLT LOCKED BACK UNTIL READY TO FIRE. KEEP THE FIREARM POINTED IN A SAFE DIRECTION WHEN LOADING AND UNLOADING.

CAUTION

ALWAYS STORE & KEEP YOUR FIREARM EMPTY, WITH THE HAMMER FORWARD AND THE MAGAZINE REMOVED.

WARNING

NEVER FIRE THE FIREARM WHEN WATER IS PRESENT IN THE BARREL, IT COULD EXPLODE AND CAUSE SEVERE INJURY OR DEATH.

WARNING

STOP FIRING IMMEDIATELY IF YOU HEAR A DIFFERENCE IN SOUND OR RECOIL. THIS COULD INDICATE AN INCOMPLETE POWDER BURN AND/OR BULLET STUCK IN THE BORE OF THE BARREL 'SQUIB ROUND'. CAREFULLY UNLOAD THE FIREARM AND INVESTIGATE THOROUGHLY BEFORE CONTINUING TO SHOOT. ONLY SHOOT IF THE BARREL IS CLEAR OF ANY OBSTRUCTION.

WARNING

BEWARE OF DANGEROUS SITUATIONS & PROCEDURES. ALWAYS MAKE SURE THAT THE CAM PIN IS INSTALLED IN THE BOLT GROUP BEFORE USE. THE FIREARM CAN STILL FIRE WITH IT MISSING AND WILL EXPLODE.

ATTENTION

UNDERSTAND AND RESPECT FIREARMS & INSTRUCT OTHERS TO DO THE SAME. ALWAYS MAKE SURE CHILDREN ARE SUPERVISED BY A COMPETENT TRAINED ADULT WHILE SHOOTING. NEVER LEAVE A LOADED FIREARM UNATTENDED & NEVER ALLOW A CHILD TO HANDLE A FIREARM UNATTENDED.

OPERATING SAFETY

CAUTION

ALWAYS MAKE SURE THAT THE BARREL BORE IS CLEAR AND FREE OF OBSTRUCTION.
ALWAYS MAKE SURE THAT THE CHAMBER AND ACTION ARE CLEAN AND CLEAR AND FREE FROM OBSTRUCTION.
ALWAYS USE ORIGINAL, DRY AND CLEAN, COMMERCIALY MANUFACTURED, HIGH QUALITY AMMUNITION.
MAKE SURE AMMUNITION IS FREE FROM DAMAGE OR DEFECTS AND ONLY USE THE CORRECT CALIBER FOR YOUR FIREARM.

CAUTION

NEVER TAKE DRUGS OR DRINK ALCOHOL BEFORE OR DURING SHOOTING.
ALWAYS MAKE SURE THAT EYE & EAR PROTECTION ARE WORN & THAT BYSTANDERS ARE ALSO WEARING SUCH PROTECTION.

CAUTION

THIS FIREARM EJECTS HOT EMPTY CASES WITH FORCE, THAT CAN CAUSE SEVERE BURNS OR INJURY IF ALLOWED TO COME INTO CONTACT WITH SKIN. ALWAYS MAKE SURE THAT BYSTANDERS ARE CLEAR OF THE EJECTION PORT AREA AND EJECTED CASES.

WARNING

IF YOUR RIFLE STOPS FIRING WITH A LIVE ROUND IN THE CHAMBER THIS COULD INDICATE A SLOW IGNITION OR MISFIRE/HANGFIRE CONDITION.
WITH THE RIFLE POINTED IN A SAFE DIRECTION WAIT FOR A COUNT OF 30 SECONDS TO SEE IF THE ROUND WILL FIRE. IF THE ROUND STILL FAILS TO FIRE THEN REMOVE THE MAGAZINE AND CYCLE THE BOLT TO EJECT THE ROUND. EXAMINE THE PRIMER CAREFULLY. IF THERE IS A LIGHT FIRING PIN MARK, AN OFF CENTER MARK OR NO MARK AT ALL THEN HAVE THE FIREARM EXAMINED BY A COMPETENT GUNSMITH BEFORE CONTINUING TO SHOOT.
IF THE ROUND CANNOT BE REMOVED, LAY THE FIREARM ON THE GROUND WITH THE MAGAZINE REMOVED & POINTING IN A SAFE DIRECTION AND WAIT A FURTHER 15 MINUTES BEFORE ATTEMPTING THE OPERATION AGAIN.

WARNING

NEVER USE THE FIREARM IF IT FAILS TO FUNCTION PROPERLY, NEVER FORCE THE ACTION IF IT BECOMES JAMMED. STOP, UNLOAD AND CAREFULLY INVESTIGATE BEFORE CONTINUING TO FIRE.

ATTENTION

NEVER ATTEMPT TO CLEAR A JAM OR BARREL OBSTRUCTION WITH THE MAGAZINE APPLIED TO THE FIREARM. NEVER POINT THE MUZZLE AT YOURSELF OR OTHERS WHILE ATTEMPTING TO CLEAR A JAM OR MALFUNCTION.

DO NOT ATTEMPT TO CLEAR BULLETS THAT HAVE BECOME STUCK IN THE BORE, TAKE THE FIREARM TO A QUALIFIED GUNSMITH FOR ASSISTANCE.

RIFLE FEATURES

THIS OPERATING MANUAL IS INTENDED FOR LANTAC 14.5" RAVEN™ RIFLES. WITH INTERMEDIATE OR MIDLENGTH GAS SYSTEMS.. THESE RIFLES USE A GAS OPERATED, DIRECT IMPINGEMENT SYSTEM THAT IS MAGAZINE FED AND SEMI AUTOMATIC IN OPERATION. MEANING THAT A SINGLE ROUND WILL FIRE EACH TIME THAT THE TRIGGER IS PULLED.

UPPER & LOWER RECEIVERS ARE MACHINED FROM BILLET 7075T6 ALUMINUM ,THEY CAN BE EASILY OPENED FOR INSPECTION & CLEANING.

PLEASE NOTE THAT SPECIFICATIONS OF THIS FIREARM ARE SUBJECT TO CHANGE WITHOUT NOTIFICATION. PLEASE CHECK WWW.LANTAC-USA.COM FOR UPDATES.

CAUTION

THIS IS A SEMI AUTOMATIC FIREARM THAT WILL RELOAD ITSELF UNTIL THE MAGAZINE IS EMPTY. IT IS THEREFORE CAPABLE OF FIRING EVERY TIME THE TRIGGER IS PULLED. TO CLEAR AND UNLOAD THE FIREARM THE MAGAZINE MUST BE REMOVED AND THE BOLT CARRIER GROUP MOVED TO THE REAR CAUSING THE LOADED ROUND TO BE EXTRACTED. PLEASE SEE PAGE 05 'CLEARING' FOR FURTHER INFORMATION.

ATTENTION

ATF REGULATIONS REQUIRE THAT YOUR FIREARM HAS A MINIMUM BARREL LENGTH OF 16", THIS LENGTH CAN BE A COMBINATION OF BARREL & PERMANENTLY FIXED (PINNED & WELDED) MUZZLE DEVICE. TOTAL LENGTH MUST BE EQUAL TO 16" OR LONGER, FROM BREECH FACE TO END OF MUZZLE DEVICE. THIS LANTAC RAVEN™ RIFLE HAS A PINNED AND WELDED BRAKE ATTACHED, THAT BRINGS THE RIFLE TO THE CORRECT LEGAL LENGTH AND SHOULD NOT BE REMOVED.

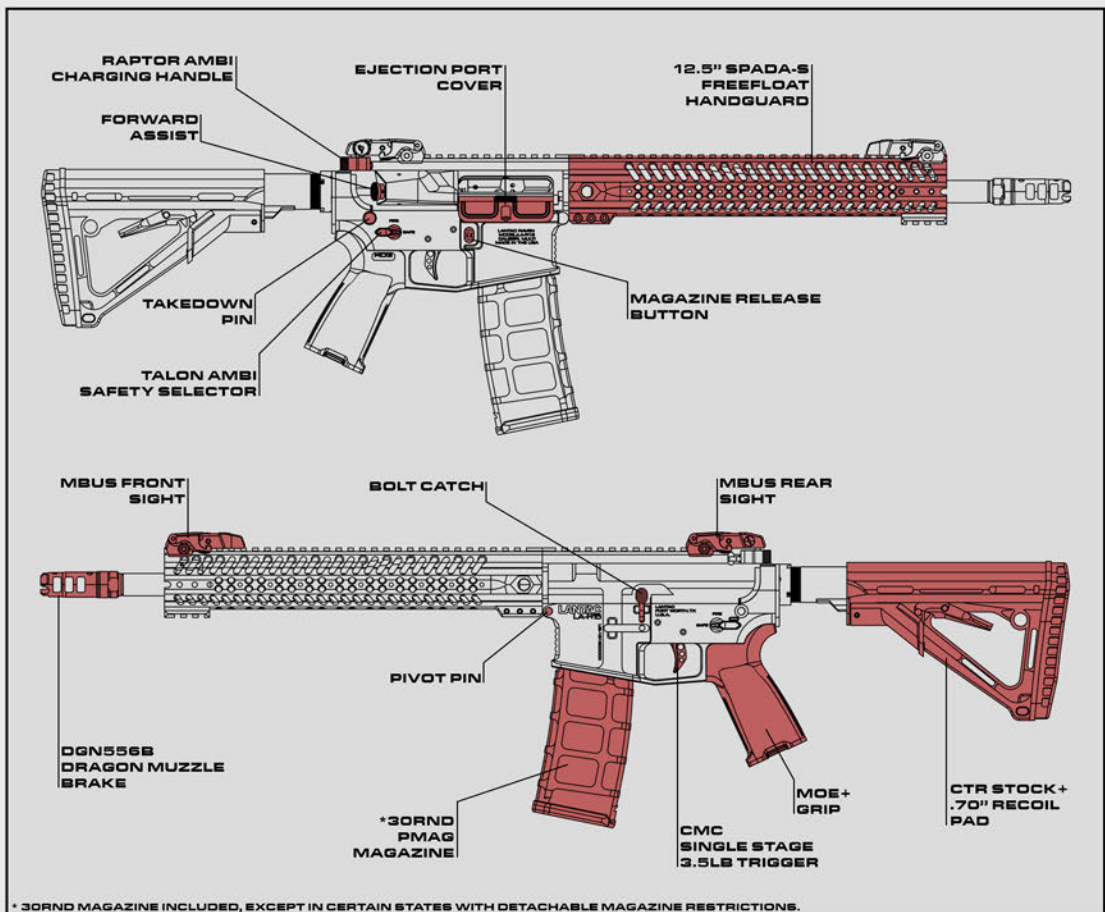

* 30RND MAGAZINE INCLUDED, EXCEPT IN CERTAIN STATES WITH DETACHABLE MAGAZINE RESTRICTIONS.

CLEARING

CAUTION

ALWAYS FOLLOW SAFE HANDLING GUIDELINES. ALWAYS ASSUME THAT THE FIREARM IS LOADED. FOLLOW THE STEPS BELOW BEFORE UNDERTAKING ANY WORK ON YOUR FIREARM.

YOUR RIFLE MUST BE CLEARED BEFORE IT IS SAFE.

1. MAKE SURE THAT THE RIFLE IS POINTING IN A SAFE DIRECTION WITH A SAFE BACKSTOP. PLACE THE SAFETY SELECTOR LEVER IN THE 'SAFE' POSITION. IF THE SELECTOR WILL NOT GO INTO 'SAFE' THEN THE HAMMER IS FORWARD AND NOT COCKED. IN THIS SITUATION THE FIREARM IS SAFE AND CANNOT FIRE, FIG 1.

ATTENTION

THE FIREARM MUST STILL BE CLEARED.

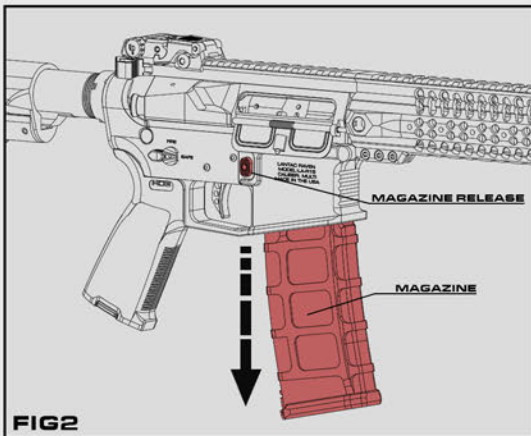

3. NOW PULL THE CHARGING HANDLE BACKWARDS UNTIL IT STOPS AND PRESS THE BOTTOM SECTION OF THE BOLT CATCH INWARDS, WITH THE BOLT CATCH DEPRESSED MOVE THE CHARGING HANDLE FORWARD UNTIL THE BOLT ENGAGES WITH THE CATCH. MAKE SURE THAT THE CHARGING HANDLE IS RE-LATCHED. THIS OPERATION WILL ALSO COCK THE HAMMER IF IT WAS FORWARD, SO THE SAFETY SELECTOR MUST NOW BE MOVED TO THE 'SAFE' POSITION IF NOT ALREADY SET, FIG3.

WARNING

IF THE BOLTS EXTRACTOR OR EXTRACTOR SPRING ARE DAMAGED OR MISSING THEN AMMUNITION WILL NOT BE EXTRACTED FROM THE CHAMBER PROPERLY. ALWAYS CHECK THAT THE CHAMBER IS CLEAR AND THAT NO AMMUNITION IS PRESENT AFTER LOCKING THE BOLT BACK AND BEFORE CONDUCTING ANY WORK ON THE FIREARM.

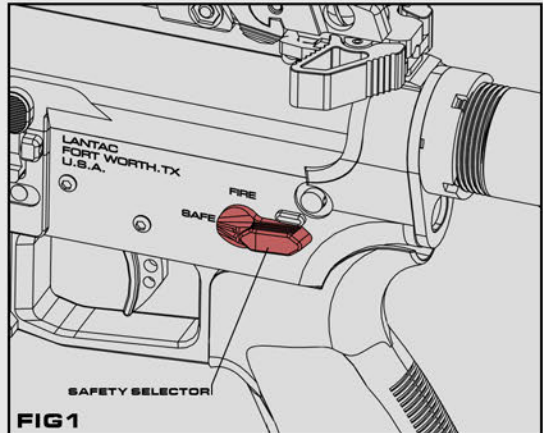

2. PRESS THE MAGAZINE CATCH RELEASE BUTTON AND CAREFULLY PULL THE MAGAZINE DOWN AND OUT OF THE MAGAZINE WELL, FIG2.

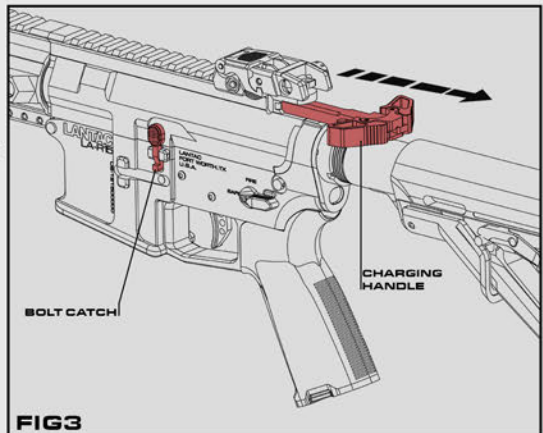

SAFETY CHECKS

!WARNING

ALWAYS CLEAN A NEW RIFLE BEFORE FIRING FOR THE FIRST TIME. IF THE RIFLE IS FIRED WITH OIL OR WATER IN THE BARREL, EXCESSIVE PRESSURE WILL BE CREATED AND MAY CAUSE THE RIFLE TO EXPLODE.

1. CHECK THE BARREL & CHAMBER TO SEE IF THERE IS EXCESSIVE OIL PRESENT. IF THERE IS THEN REMOVE IT WITH A PATCH AND CLEANING ROD.

2. RETRACT THE BOLT TO ENSURE THAT IT CAN MOVE FREELY AND THERE IS NO BINDING BETWEEN THE GAS KEY AND GAS TUBE. THE BOLT CARRIER GROUP SHOULD MOVE FREELY WITHIN THE UPPER RECEIVER, FIG 1.

3. PERFORM A SAFETY FUNCTION CHECK AS DETAILED BELOW TO MAKE SURE THAT THE FIREARMS SAFETY SELECTOR ENGAGES PROPERLY AND THE RIFLE IS SAFE TO USE.

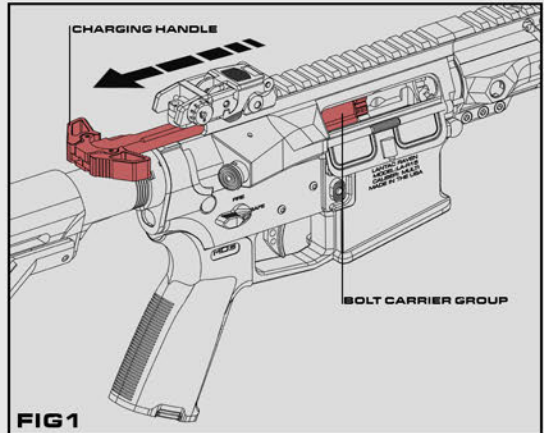

FIG 1

!WARNING

IF THE RIFLE FAILS ANY OF THE FOLLOWING SAFETY CHECKS THEN IT SHOULD NOT BE USED. CONTINUED USE OF THE FIREARM MAY RESULT IN SEVERE INJURY OR DEATH. HAVE A COMPETENT GUNSMITH INVESTIGATE THE PROBLEMS OR CONTACT LANTAC USA LLC DIRECT.

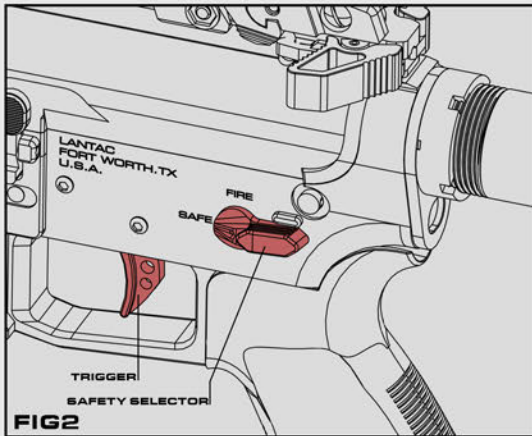

FIG2

5. NOW PLACE THE SAFETY SELECTOR IN THE 'FIRE' POSITION AND PULL THE TRIGGER, FIG3.

!ATTENTION

THE HAMMER SHOULD FALL. YOU SHOULD HEAR A 'CLICK'.

4. WITH THE RIFLE POINTED IN A SAFE DIRECTION, PLACE THE SELECTOR IN THE 'SAFE' POSITION AND PULL THE TRIGGER, FIG2.

!ATTENTION

THE HAMMER SHOULD NOT MOVE, IF YOU HEAR A 'CLICK' AND THE HAMMER HAS MOVED THERE IS SOMETHING WRONG!!!

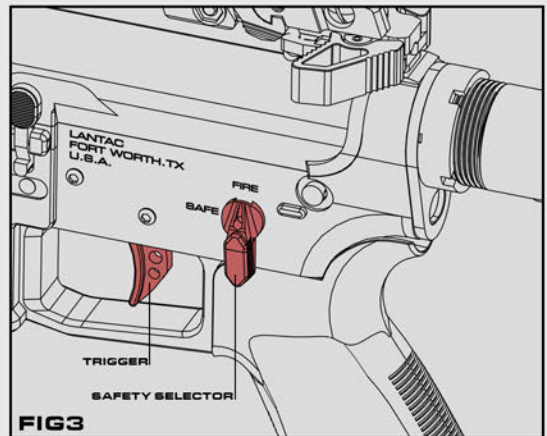

FIG3

6. WITH THE TRIGGER HELD TO THE REAR, PULL THE CHARGING HANDLE BACK AND THEN RELEASE. NOW SLOWLY RELEASE PRESSURE ON THE TRIGGER IN A SMOOTH CONTROLLED MOTION, UNTIL THE TRIGGER IS FULLY FORWARD.

YOU SHOULD HEAR AN AUDIBLE 'CLICK' AS THE HAMMER MOVES FROM THE SECONDARY SEAR TO THE PRIMARY. THE HAMMER SHOULD NOT FALL!!!

5. REPEAT THIS SAFETY FIRE TEST A FURTHER FIVE (5) TIMES. THE RIFLE MUST NOT FAIL ANY OF THESE TESTS. IF THE RIFLE MALFUNCTIONS HAVE A QUALIFIED GUNSMITH CHECK THE FIREARM OR CONTACT LANTAC USA LLC DIRECTLY.

OPERATION

!WARNING

ALWAYS FOLLOW SAFE FIREARMS HANDLING DISCIPLINE.
ONLY LOAD AMMUNITION INTO THE FIREARM WHEN YOU ARE READY TO SHOOT,
DO NOT STORE YOUR FIREARM LOADED, DO NOT LEAVE YOUR FIREARM LOADED.

!ATTENTION

LOAD THE MAGAZINE, USE ONLY HIGH QUALITY FACTORY AMMUNITION OF THE
CORRECT CALIBER. MAKE SURE THE AMMUNITION IS CLEAN AND FREE OF DEFECTS.
CAREFULLY CHECK THE AMMUNITION, LOOKING FOR DENTS, SCRATCHES AND ANY
OTHER SIGNS OF DAMAGE.

!WARNING

DO NOT LOAD OR USE DAMAGED AMMUNITION.

1. WITH THE HAMMER COCKED, SET THE
SAFETY SELECTOR TO THE 'SAFE'
POSITION, SLIDE THE BOLT BACK AND
CHECK THAT THE CHAMBER IS CLEAR,
FIG1.

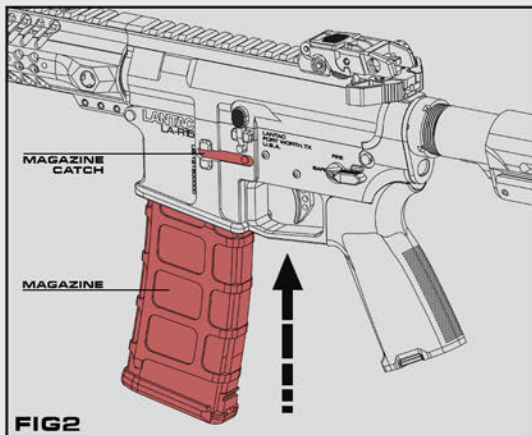

FIG2

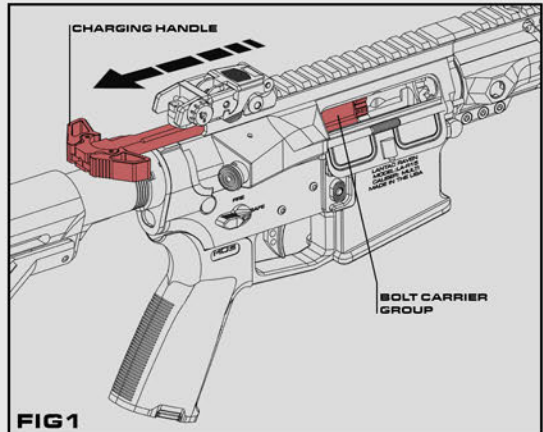

FIG1

2. NOW RETURN THE CHARGING HANDLE
TO ITS FORWARD, LOCKED
POSITION. APPLY A LOADED MAGAZINE TO THE MAG
WELL BY PUSHING IT UP INTO THE WELL
UNTIL IT CATCHES ON THE MAGAZINE
CATCH, FIG2.

3. MAKE SURE THE MAGAZINE IS FIXED
PROPERLY BY PUSHING FIRMLY UP &
THEN PULLING DOWN ON IT.

NOTE: THE MAGAZINE CAN BE APPLIED TO THE RIFLE WITH THE BOLT OPEN OR
CLOSED.

4. CHAMBERING A ROUND WITH THE BOLT LOCKED BACK (OPEN BOLT).
WITH THE MAGAZINE APPLIED, FIG2. DEPRESS THE TOP PORTION OF THE BOLT
CATCH, THE BOLT CARRIER GROUP SHOULD MOVE FORWARD UNDER SPRING
PRESSURE, COLLECTING A ROUND FROM THE MAGAZINE AND CHAMBERING IT
IN THE BARREL, FIG3.

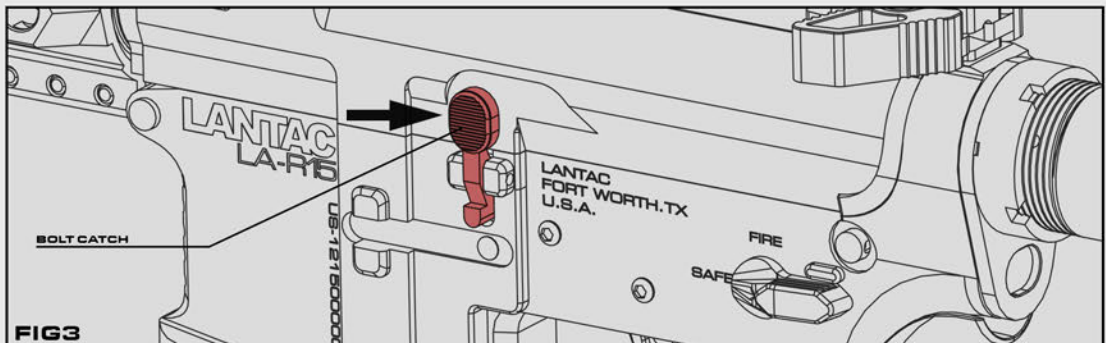
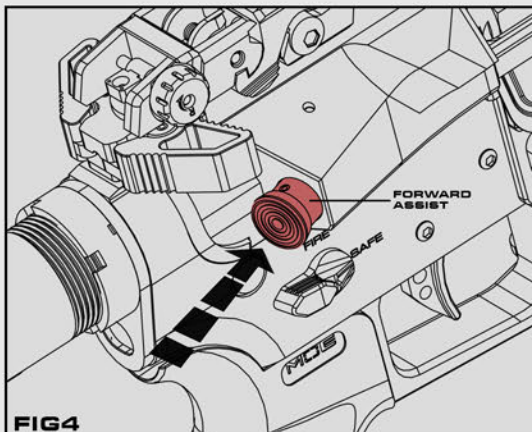

FIG3

5. PUSH THE FORWARD ASSIST WITH THE HEEL OF YOUR HAND TO MAKE SURE THAT THE BOLT IS FULLY FORWARD AND IN BATTERY, FIG4.

ATTENTION

THE FIREARM IS NOW READY TO BE AIMED AND FIRED!!!



6. CHAMBERING A ROUND WITH THE BOLT FORWARD (CLOSED BOLT). WITH THE MAGAZINE APPLIED, FIG2. PULL THE CHARGING HANDLE FULLY TO THE REAR, THEN RELEASE ALLOWING THE BOLT AND HANDLE TO MOVE FORWARDS. THE BOLT WILL COLLECT A ROUND FROM THE MAGAZINE AND CHAMBER IT IN THE BARREL, FIG5.

7. MAKE SURE THAT THE CHARGING HANDLE IS FULLY FORWARD IN ITS LOCKED POSITION.

CAUTION

NEVER PUSH OR RIDE THE CHARGING HANDLE FORWARD, ALWAYS ALLOW IT TO MOVE FORWARD WITH FULL FORCE FROM THE ACTION SPRING.

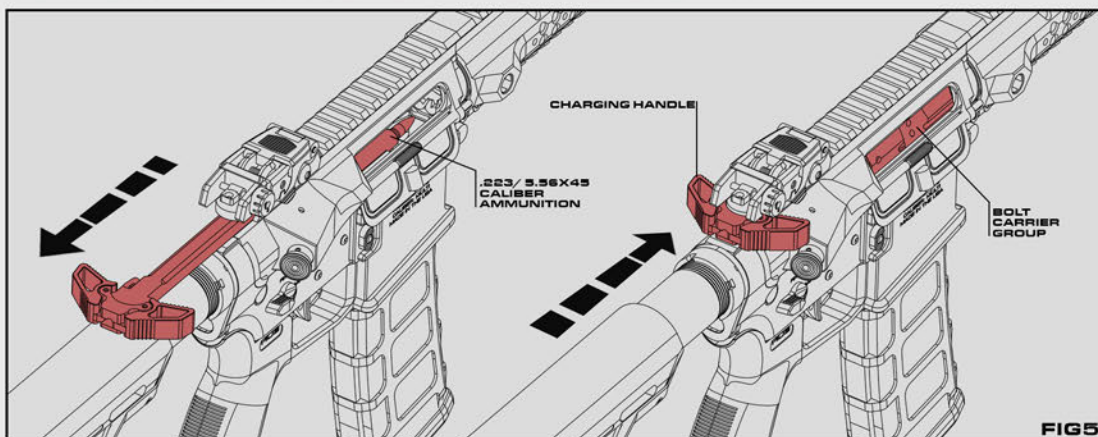

8. PUSH THE FORWARD ASSIST WITH THE HEEL OF YOUR HAND TO MAKE SURE THAT THE BOLT IS FULLY FORWARD AND IN BATTERY, FIG5.

ATTENTION

THE FIREARM IS NOW READY TO BE AIMED AND FIRED!!!

ATTENTION

IF THE FIREARM IS NOT GOING TO BE FIRED IMMEDIATELY THEN MAKE SURE THAT THE SAFETY SELECTOR IS IN THE 'SAFE' POSITION. THE EJECTION PORT COVER CAN BE CLOSED TO REDUCE INGRESS OF DIRT INTO THE UPPER RECEIVER.

CAUTION

REMEMBER, THE FIREARM IS NOW LOADED, A ROUND IS CHAMBERED. THE SAFETY SELECTOR SHOULD BE IN THE 'SAFE' POSITION AND THE FIREARM POINTED IN A SAFE DIRECTION WITH AN ADEQUATE BACKSTOP.

WARNING

ALWAYS KEEP THE MUZZLE OF THE FIREARM POINTED IN A SAFE DIRECTION.

ABS™ BUFFER

THIS RAVEN™ RIFLE FEATURES A PROPRIETARY ADJUSTABLE BUFFER SYSTEM, ABS™ THAT ALLOWS THE USER TO MODIFY THE PRELOAD OF THE ACTION SPRING BY ALTERING THE HEAD DEPTH OF THE BUFFER ITSELF CREATING INCREASED PRESSURE ON THE BOLT CARRIER GROUP.

THIS ADDITIONAL PRESSURE INCREASES BOLT 'LOCK TIME' AND ALSO MEANS THAT RECOIL ENERGY IS DAMPENED DIFFERENTLY. DEPENDING ON THE AMMUNITION BEING FIRED THE BUFFER CAN BE USED TO REDUCE CONSIDERABLE RECOIL. IT IS EVEN POSSIBLE TO CAUSE THE RIFLE TO 'SHORT STROKE' IF ADJUSTMENT IS TAKEN TOO FAR. BY ADJUSTING THE BUFFER TO THE CLOSEST FUNCTIONING POINT OFF SHORT STROKING THE RIFLE CAN BE MADE TO SHOOT WITH VIRTUALLY ZERO RECOIL WHILE STILL FUNCTIONING AT 100% CAPACITY.

THE SYSTEM UTILIZES ONLY A MECHANICAL DESIGN, MEANING THAT AN ADJUSTABLE GAS BLOCK IS NOT REQUIRED.

CAUTION

MAKE SURE THAT THE FIREARM IS UNLOADED, THE MAGAZINE IS REMOVED AND THE CHAMBER EMPTY BEFORE UNDERTAKING ANY ADJUSTMENT OF THE RIFLES ABS™ BUFFER SYSTEM.

IF THE HAMMER IS COCKED THEN THE SAFETY SHOULD BE APPLIED TO THE 'SAFE' POSITION TO SAFEGUARD AGAINST THE HAMMER FLYING FORWARD AND STRIKING THE LOWER RECEIVER IF THE TRIGGER IS ACCIDENTALLY PULLED.

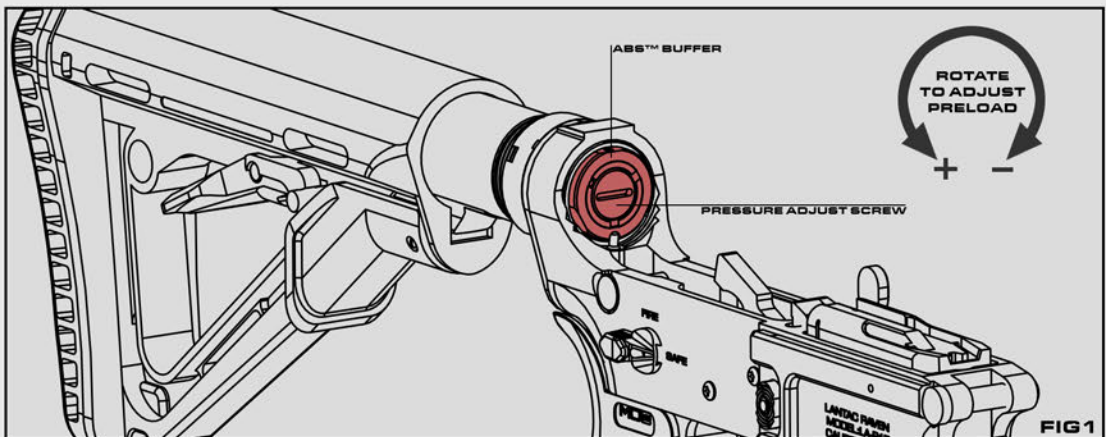

THE SYSTEM CAN BE ADJUSTED BY INSERTING A COIN, SCREWDRIVER OR OTHER SUITABLE FLAT TOOL INTO THE SLOT ON THE FACE OF THE BUFFER'S PRESSURE SCREW. ROTATION TO THE RIGHT REDUCES SPRING PRESSURE, ROTATION TO THE LEFT INCREASES SPRING PRESSURE, FIG 1.

WE RECOMMEND YOU COUNT CLICKS OR ROTATIONS OF THE PRESSURE SCREW UNTIL THE SOFTEST RECOIL FOR THE AMMUNITION IN USE IS OBTAINED. WRITE THE INFORMATION DOWN SO THAT YOU CAN REFER BACK TO IT SHOULD YOU CHANGE AMMUNITION IN THE FUTURE.

ATTENTION

DO NOT FORCE ADJUSTMENT OF THE PRESSURE SCREW PAST THE STOP POSITIONS. IF THE BUFFER ROTATES AS YOU ATTEMPT TO MOVE THE SCREW KEEP ROTATING UNTIL THE NOTCH ON THE FRONT FACE ENGAGES WITH THE BUFFER DETENT AND LOCKS INTO PLACE. YOU WILL THEN BE ABLE TO ADJUST THE PRESSURE SCREW PROPERLY.

THE ABS™ BUFFER SYSTEM IS ONLY DESIGNED TO WORK WITH THE SPECIAL ACTION SPRING SUPPLIED. IT WILL NOT FUNCTION WITH OTHER AFTER MARKET SPRINGS, USE OF THESE SPRINGS MAY RENDER THE RIFLE INOPERABLE AND CAUSE DAMAGE.

FIRING

!WARNING

ALWAYS KEEP THE MUZZLE OF THE FIREARM POINTED IN A SAFE DIRECTION. ALWAYS FOLLOW SAFE FIREARMS HANDLING PROCEDURES.

THIS RAVEN™ RIFLE IS SEMI AUTOMATIC IN OPERATION AND WILL FIRE A SINGLE ROUND EVERYTIME THE TRIGGER IS PULLED UNTIL THE MAGAZINE IS EMPTY. TO START THE FIRING PROCEDURE WITH A LOADED RIFLE, PLACE THE SAFETY SELECTOR INTO THE 'FIRE' POSITION, FIG1.

CAREFULLY AIM AT THE TARGET MAKING SURE YOU HAVE A SAFE BACKSTOP AND SLOWLY PULL THE TRIGGER.

THE RIFLE WILL FIRE, AUTOMATICALLY EJECT THE EMPTY CASE & RELOAD ITSELF. READY TO BE FIRED AGAIN.

THIS CYCLE CAN BE CONTINUED UNTIL THE MAGAZINE IS EMPTY.

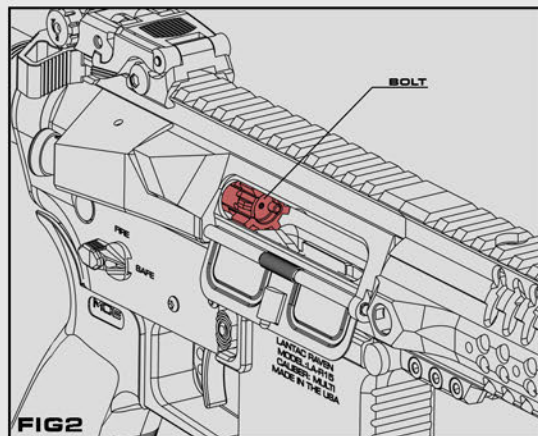
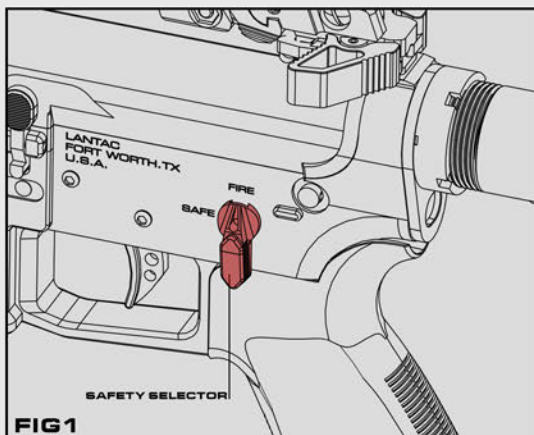

!ATTENTION

WHEN THE LAST ROUND IS FIRED & THE MAGAZINE IS EMPTY THE BOLT WILL LOCK OPEN, FIG2.

PRESS THE MAGAZINE RELEASE BUTTON AND REMOVE THE EMPTY MAGAZINE AS DETAILED ON PAGE 05 'CLEARING', FIG2. APPLY A FRESH MAGAZINE BY PUSHING IT UP INTO THE MAGWELL AND THEN PRESS THE BOLT CATCH BUTTON TO SEND THE BOLT FORWARDS AND RELOAD THE RIFLE.

SEE PAGES 07 & 08 'OPERATION' FOR FURTHER INFORMATION.

!WARNING

STOP FIRING IMMEDIATELY IF YOU HEAR A DIFFERENCE IN SOUND OR RECOIL. THIS COULD INDICATE AN INCOMPLETE POWDER BURN AND/OR BULLET STUCK IN THE BORE OF THE BARREL 'SQUIB ROUND'.

CAREFULLY UNLOAD THE FIREARM AND INVESTIGATE THOROUGHLY BEFORE CONTINUING TO SHOOT.

ONLY SHOOT IF THE BARREL IS CLEAR OF ANY OBSTRUCTION.

SEE PAGE 11 'FAILURE RECOVERY' FOR FURTHER INFORMATION.

IF A BULLET IS LODGED IN THE BARREL DO NOT ATTEMPT TO REMOVE IT.

TAKE THE FIREARM TO A QUALIFIED GUNSMITH FOR ASSISTANCE.

FAILURE RECOVERY

!WARNING

ALWAYS KEEP THE MUZZLE OF THE FIREARM POINTED IN A SAFE DIRECTION. ALWAYS FOLLOW SAFE FIREARMS HANDLING PROCEDURES. IF YOUR RIFLE STOPS FIRING, YOU CAN PERFORM THE FOLLOWING IMMEDIATE ACTIONS THAT MAY SOLVE THE PROBLEM.

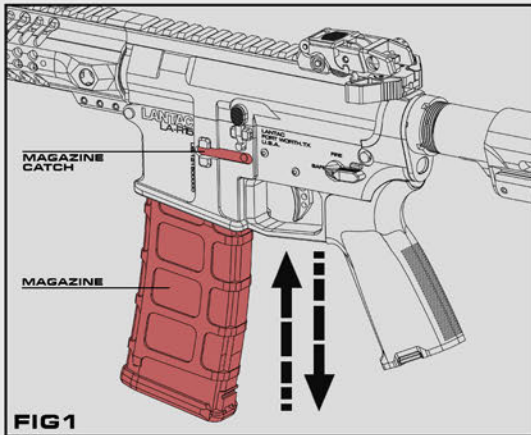

1. CHECK TO SEE THAT THE MAGAZINE IS INSERTED PROPERLY AND HAS ENGAGED WITH THE MAGAZINE CATCH. CHECK BY PUSHING THE MAGAZINE UP INTO THE MAGAZINE WELL & THEN PULL DOWN, FIG1.

2. CHECK THE CHAMBER FOR OBSTRUCTIONS. PULL THE CHARGING HANDLE BACKWARDS TO OPEN THE BOLT OR CARTRIDGE AND THEN CHECK THE CHAMBER, FIG2.

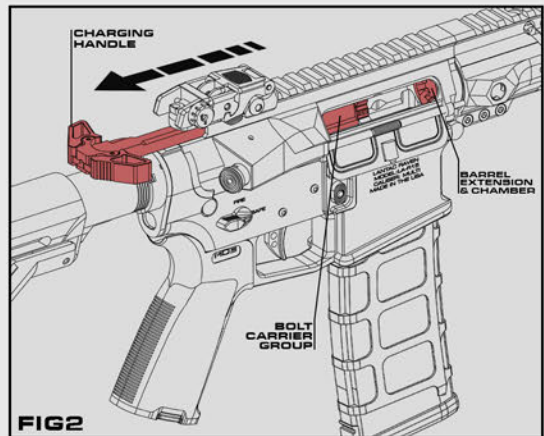

!WARNING

DO NOT LOAD AMMUNITION INTO A VERY HOT CHAMBER. AMMUNITION CAN HEAT TO THE POINT WHERE IT WILL DETONATE OF ITS OWN ACCORD. THIS IS KNOWN AS 'COOKING OFF'. ALLOW THE CHAMBER AND BARREL TO COOL BEFORE RELOADING.

3. IF A CARTRIDGE OR CASE WAS EJECTED THEN RELEASE THE CHARGING HANDLE AND ALLOW THE BOLT CARRIER GROUP TO TRAVEL FORWARD, PICK UP A NEW ROUND FROM THE MAGAZINE AND RELOAD THE RIFLE, FIG3.

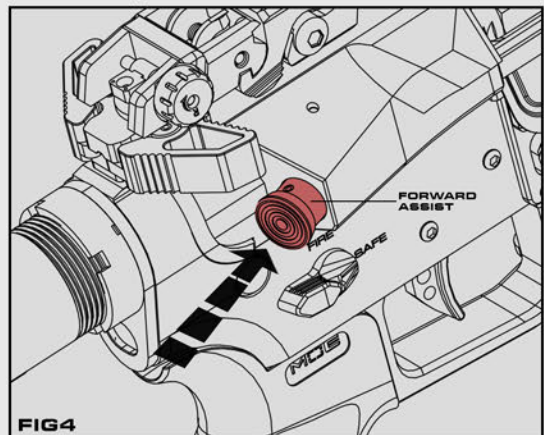
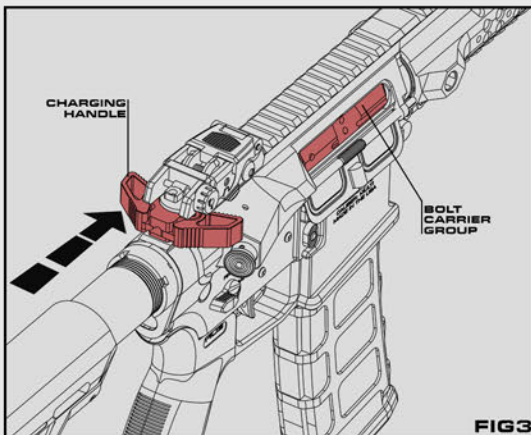

5. PUSH THE FORWARD ASSIST WITH THE HEEL OF YOUR HAND TO MAKE SURE THAT THE BOLT IS FULLY FORWARD AND IN BATTERY, FIG4.

5. PULL THE TRIGGER, FIG5.
IF THE RIFLE DOES NOT FIRE THEN
PROCEED WITH THE REMEDIAL ACTIONS
LISTED BELOW.

!WARNING

IF YOUR RIFLE STOPS FIRING WITH A
ROUND IN A HOT CHAMBER IT IS
IMPORTANT TO REMOVE THE ROUND AS
FAST AS POSSIBLE. IF THE ROUND CANNOT
BE REMOVED WITHIN 10 SECONDS THEN
REMOVE THE MAGAZINE AND POINT THE
RIFLE IN A SAFE DIRECTION. WAIT 15
MINUTES BEFORE ATTEMPTING TO
REMOVE THE ROUND AGAIN.

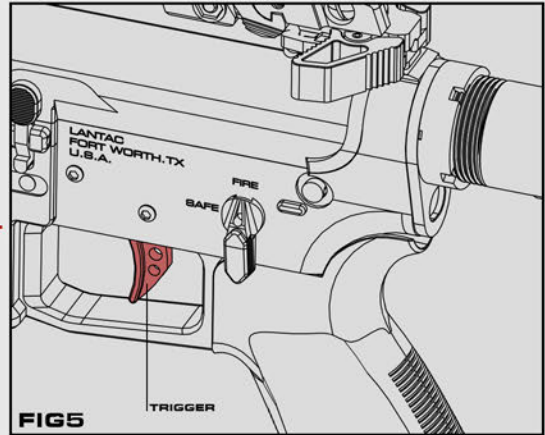

!CAUTION

MAKE SURE YOU KEEP YOUR FACE AWAY FROM THE EJECTION PORT AREA WHEN
CLEARING A ROUND FROM A HOT CHAMBER.

!ATTENTION

IN THE EVENT THAT YOUR RIFLE STILL FAILS TO FIRE CHECK AGAIN THAT THERE IS NOT
A JAMMED CARTRIDGE IN THE CHAMBER.

IF A JAMMED CARTRIDGE IS PRESENT THEN IT CAN USUALLY BE REMOVED BY
OPENING THE RIFLE, REMOVING THE BOLT CARRIER GROUP AND INSERTING A
CLEANING ROD DOWN THE BARREL, THEN CAREFULLY 'TAP' THE ROD TO MOVE THE
ROUND FROM THE CHAMBER.

THE CHAMBER SHOULD BE INSPECTED BY A QUALIFIED GUNSMITH FOR POTENTIAL
DAMAGE.

!WARNING

IF YOU HEAR A DIFFERENT SOUND WHEN FIRING OR EXPERIENCE A DIFFERENT
RECOIL FEELING IT COULD MEAN THAT THERE HAS BEEN AN INCOMPLETE POWDER
BURN AND THAT A BULLET IS NOW JAMMED IN THE BORE.

STOP FIRING IMMEDIATELY.

UNDERTAKE THE FOLLOWING STEPS.

1. REMOVE THE MAGAZINE
2. LOCK THE BOLT CARRIER GROUP TO THE REAR
3. PUT THE SAFETY SELECTOR IN THE 'SAFE' POSITION.
4. MAKE SURE THAT THERE IS NOT A ROUND IN THE CHAMBER, THE CHAMBER MUST
BE CLEAR.

NOW CAREFULLY INSPECT THE BORE OF THE BARREL FOR OBSTRUCTIONS.
A CLEANING ROD CAN ALSO BE USED TO INDICATE A BLOCKAGE.

!WARNING

IF THERE IS A BULLET JAMMED IN THE BORE OF THE BARREL DO NOT APPLY THE
FAILURE RECOVERY STEPS DETAILED HERE.

DO NOT TRY TO REMOVE THE BULLET.

TAKE THE FIREARM TO A QUALIFIED GUNSMITH FOR ASSISTANCE.

DISASSEMBLY

!WARNING

MAKE SURE YOUR RIFLE IS CLEAR, FOLLOW THE STEPS ON PAGE 05 'CLEARING'.

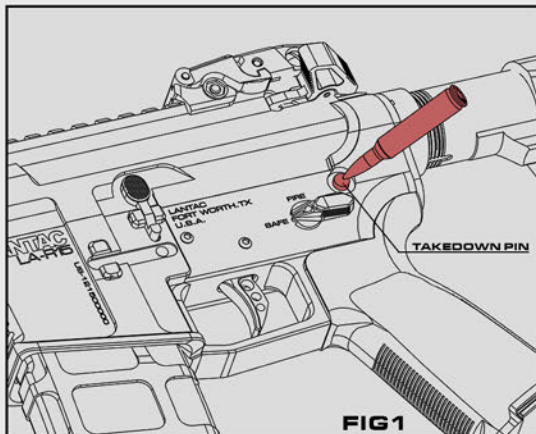

1. CLEAR YOUR RIFLE. THE UPPER AND LOWER RECEIVERS OF YOUR RIFLE CAN EASILY BE SEPERATED.

PUSH IN THE REAR TAKEDOWN PIN AS FAR IN AS IT WILL GO, A BULLET TIP OR PUNCH CAN BE USED, FIG1.

!ATTENTION

DO NOT HAMMER THE TAKEDOWN PIN OR FORCE IT PAST ITS STOP POSITION. IF THE PIN IS TIGHT THEN SQUEEZE THE RECEIVERS TOGETHER AT THE SAME TIME AS YOU PUSH IN THE PIN.

2. NOW PUSH IN THE FRONT PIVOT PIN.

PUSH IN THE PIVOT PIN AS FAR AS IT WILL GO, A BULLET TIP OR PUNCH CAN BE USED, FIG2.

!ATTENTION

DO NOT HAMMER THE PIVOT PIN OR FORCE IT PAST ITS STOP POSITION. IF THE PIN IS TIGHT THEN SQUEEZE THE RECEIVERS TOGETHER AT THE SAME TIME AS YOU PUSH IN THE PIN.

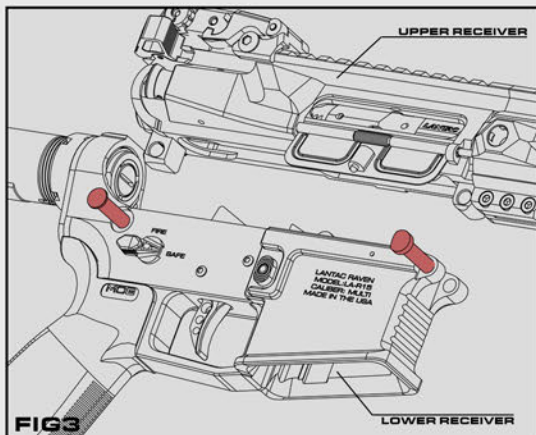
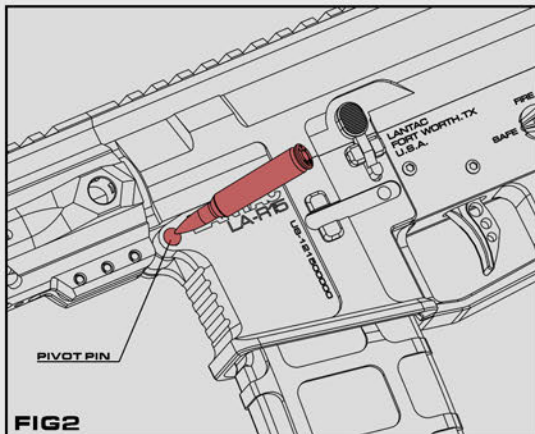

3. NOW SEPERATE THE UPPER AND LOWER RECEIVERS, FIG3.

NOTE THE TAKEDOWN & PIVOT PINS ARE RETAINED.

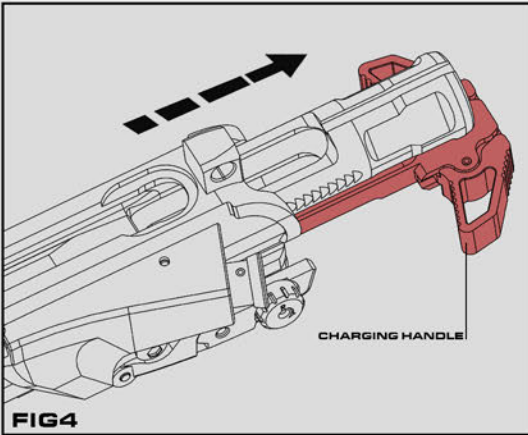

4. PULL BACK THE CHARGING HANDLE & THE BOLT CARRIER GROUP WILL SLIDE OUT WITH IT, FIG4.

5. REMOVE THE BOLT CARRIER GROUP BY PULLING IT OUT AND UP. MAKE SURE THE CHARGING HANDLE IS FULLY RETRACTED OR IT WILL BE DIFFICULT TO REMOVE THE BOLT CARRIER GROUP, FIG5.

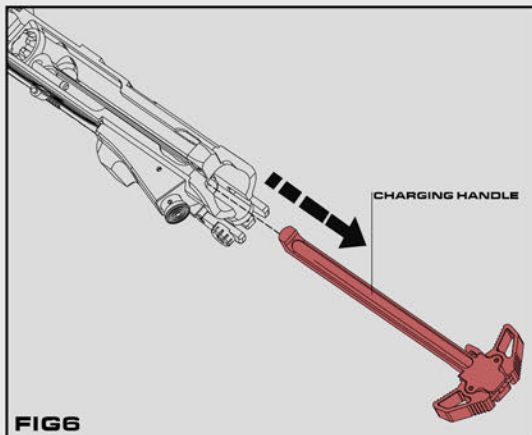
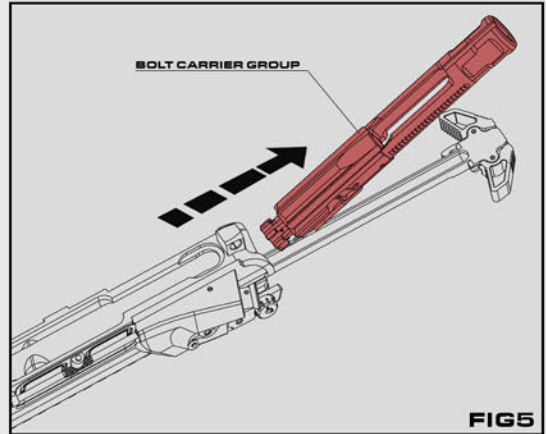

6. NOW REMOVE THE CHARGING HANDLE. PULL IT BACK AND UP AT THE SAME TIME UNTIL THE LUGS CLEAR THE RECEIVER CUTOUTS, FIG6.

7. REMOVE THE FIRING PIN RETAINING PIN FROM THE BOLT CARRIER, FIG7.

ATTENTION

BE CAREFUL NOT TO DAMAGE THE RETAINING PIN. IF YOU LOSE THE PIN IT MUST BE REPLACED WITH A PROPER VERSION. A STANDARD COTTER PIN CANNOT BE USED.

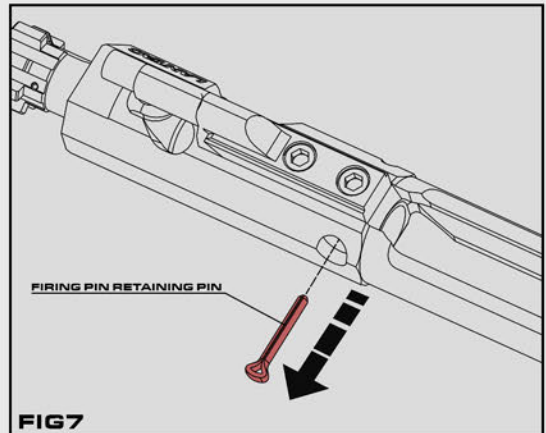

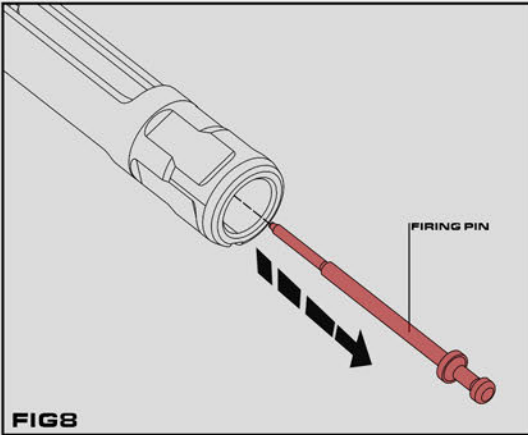

8. REMOVE THE FIRING PIN BY GENTLY TAPPING THE REAR OF THE CARRIER ON A SOFT SURFACE, THE PIN SHOULD FALL OUT OF THE BOTTOM OF THE CARRIER, FIG8.

9. MAKE SURE THAT THE BOLT IS IN THE REARWARD 'LOCKED' POSITION, IF IT ISN'T THEN PUSH IT INTO THE CARRIER BY HAND, THIS WILL PLACE THE CAM PIN IN THE CORRECT POSITION FOR REMOVAL, FIG9.

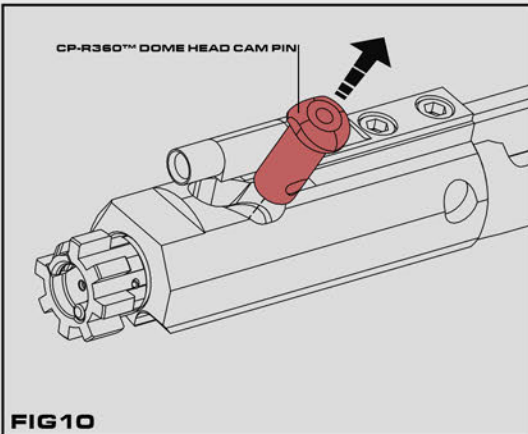
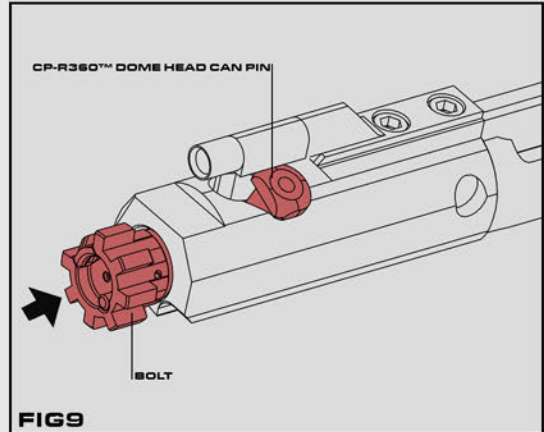

10. REMOVE THE CP-R360™ CAM PIN BY ROTATING IT 90°. MAKE SURE THAT THE FLAT FACE IS POINTING TOWARDS THE GAS KEY AND PULL IT OUT OF THE CARRIER, FIG10.

11. NOW REMOVE THE BOLT FROM THE CARRIER BY PULLING IT STRAIGHT OUT, FIG11.

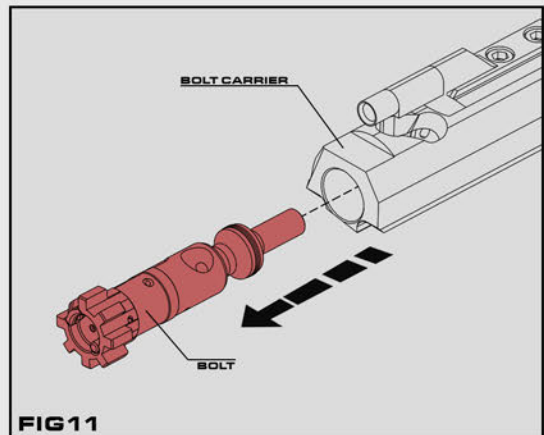

ATTENTION

SEE EXPLODED DIAGRAMS SECTION OF THIS BOOKLET FOR PARTS IDENTIFICATION.

! ATTENTION

PROCEED WITH THE FOLLOWING DISASSEMBLY ONLY WHEN REQUIRED. I.E... IF THE PARTS ARE DAMAGED OR DIRTY.

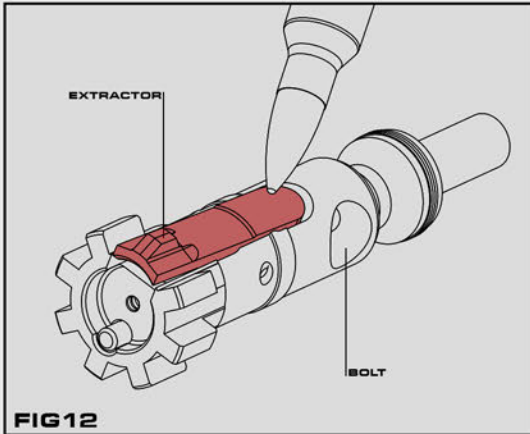

13. NOW CAREFULLY REMOVE THE EXTRACTOR RETAINING PIN BY PUSHING IT OUT USING A PUNCH OR BULLET TIP. MAKE SURE YOU DO NOT LOSE THE PART, FIG 13.

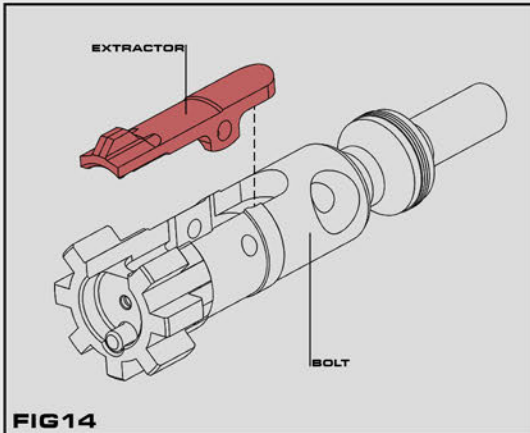

15. COCK THE HAMMER AND PLACE THE SAFETY SELECTOR IN 'SAFE', DEPRESS THE BUFFER RETAINER, FIG 15.

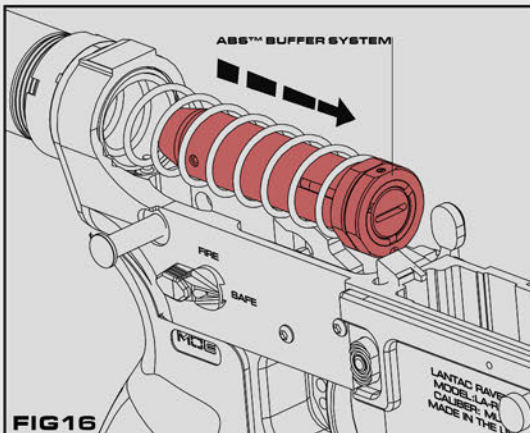

12. FIRST CHECK EXTRACTOR FUNCTION. PRESS THE REAR END OF THE EXTRACTOR IN, USING A PUNCH OR BULLET TIP, MAKE SURE THE EXTRACTOR MOVES FREELY AND THE SPRING IS WORKING, FIG 12.

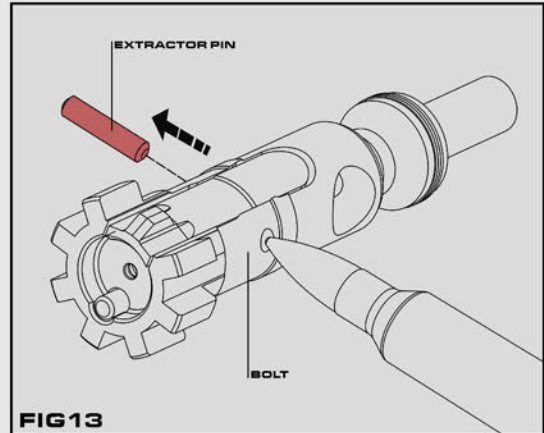

14. REMOVE THE EXTRACTOR, BEING CAREFUL NOT TO LOSE THE SPRING, SPRING INSERT OR 'O' RING, FIG 14.

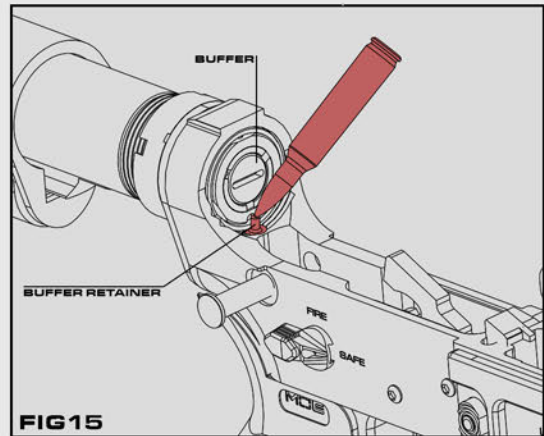

! ATTENTION

16. THE BUFFER IS UNDER SPRING TENSION, PROCEED WITH CAUTION. IT MAY BE NECESSARY TO WIND THE BUFFER HEAD TO ITS SHORTEST DEPTH IN ORDER TO GET THE ASSEMBLY PAST THE BUFFER RETAINER, FIG 16.

! ATTENTION

NO FURTHER DISASSEMBLY IS RECOMMENDED.

INSPECTION & CLEANING

ATTENTION

AFTER FIRING YOUR RIFLE FOR ANY LENGTH OF TIME IT SHOULD BE CLEANED AND MAINTAINED AS SOON AS IS PRACTICALLY POSSIBLE. THIS WILL ASSIST IN KEEPING IT RUNNING PROPERLY.

BE AWARE OF STORAGE CONDITIONS AND RELATIVE HUMIDITY THAT MAY CAUSE CORROSION, KEEP THE FIREARM OILED AND CHECK IT PERIODICALLY IF IT IS STORED FOR ANY GREAT LENGTH OF TIME WITHOUT BEING USED.

ATTENTION

SHOULD YOUR FIREARM GET WET IT IS VITAL THAT IT IS DRIED PROPERLY, INSPECTED AND CLEANED / OILED TO PREVENT CORROSION BUILD UP.

WE RECOMMEND YOU PURCHASE A HIGH QUALITY CLEANING KIT, WITH CLEANING ROD AND BORE GUIDE. YOU WILL ALSO NEED A SMALL TOOTHBRUSH, PIPE CLEANERS, Q-TIPS AND CLOTH.

LANTAC USA LLC RECOMMENDS FROGLUBE™ CLP. USE OF OTHER CLEANERS AND LUBRICANTS IS NOT RECOMMENDED AND MAY CAUSE HARM TO YOUR FIREARM.

ATTENTION

AFTER YOU HAVE DISASSEMBLED YOUR RIFLE THOROUGHLY INSPECT, CLEAN & LUBRICATE ALL PARTS.

FOLLOW THE CLEANING GUIDE BELOW.

UPPER RECEIVER

ATTENTION

CHECK THE BARREL AND UPPER RECEIVER FIT, MAKE SURE THAT THERE IS NO MOVEMENT, THE PARTS SHOULD BE TIGHT WITH NO LOOSENESS. IF YOU DETECT ANY MOVEMENT THEN TAKE THE RIFLE TO A QUALIFIED GUNSMITH FOR ASSISTANCE.

1. CLEAN ALL INTERNAL AND EXTERNAL SURFACES TO REMOVE PROPELLANT FOULING. NEVER USE ANYTHING ABRASIVE TO CLEAN THE RECEIVERS. USE Q-TIPS AND CLOTH TO CLEAN AROUND THE GAS TUBE AREA AND A TOOTH BRUSH TO DISLodge MORE STUBBORN MATERIAL.

2. CLEAN THE CHAMBER AND BARREL EXTENSION AREA. PAY SPECIAL ATTENTION TO THE CHAMBER AND TAKE CARE NOT TO SCRATCH OR DAMAGE IT.

3. USE A BORE BRUSH TO CLEAN OUT THE BORE, INSPECT IT BY HOLDING THE BARREL UP TO A LIGHT SOURCE SO THAT THE BORE SURFACE IS VISIBLE, USE PATCHES TO CLEAN UP ANY FOULING AND THEN USE A MOP TO LIGHTLY APPLY LUBRICATION TO THE BORE. TAKE CARE NOT TO DAMAGE THE BORE WITH THE BRUSH, USE A BORE GUIDE TO ASSIST IN ALIGNMENT.

5. WIPE ALL PARTS DOWN WITH A CLEAN DRY CLOTH. LEAVE THEM TO DRY NEAR A HEATER IF NECESSARY.

INSPECT ALL PARTS FOR DAMAGE AND CORROSION. HAVE A QUALIFIED GUNSMITH REPLACE ANY WORN, DEFECTIVE OR DAMAGED PARTS BEFORE SHOOTING THE RIFLE AGAIN.

BOLT CARRIER GROUP

1. CAREFULLY CLEAN OUT THE GAS KEY WITH A Q-TIP, MAKE SURE THERE IS NO OBSTRUCTION AND BLOW OUT WITH AIR IF POSSIBLE. CLEAN THE GAS PORTS WITH A PIPE CLEANER, MAKE SURE THEY ARE FREE OF FOULING AND CLEAR. CLEAN THE CARRIER BORE AND WIPE OUT WITH A SOFT CLOTH, FIG1.

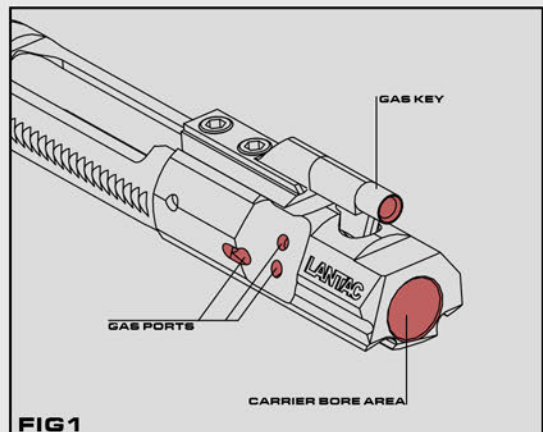

2. CLEAN AND INSPECT THE BOLT THOROUGHLY, LOOK FOR CRACKS AND DAMAGE TO THE LUGS AND AROUND THE CAM PIN HOLE.

ATTENTION

CHECK THE CAM PIN FOR WEAR OR DAMAGE, REPLACE IF NECESSARY. PLEASE NOTE THAT THE CAM PIN CAN ONLY BE INSTALLED INTO ONE SIDE OF THE BOLT, THIS IS TO MAKE SURE THAT THE BOLT IS ALWAYS POSITIONED AT THE CORRECT ANGLE WHEN FITTED TO THE CARRIER.

CHECK THE FIRING PIN, IF IT IS DAMAGED, BLUNT, BENT, CRACKED OR TOO SHARP REPLACE IT.
A FIRING PIN PROTRUSION GAUGE CAN BE PURCHASED TO TEST PIN DEPTH WHEN FITTED IN THE BOLT.

CHECK THE FIRING PIN RETAINING PIN. IF IT IS DAMAGED, BENT OR WORN IT SHOULD BE REPLACED. ALWAYS USE A PROPER RETAINING PIN, COTTER PINS ARE NOT MADE FROM THE CORRECT MATERIAL AND CANNOT BE USED AS A REPLACEMENT.

CLEAN THE CAM PIN, FIRING PIN, BOLT, RETAINING PIN, EXTRACTOR AND EXTRACTOR SPRING THOROUGHLY, FIG 2.

WARNING

DO NOT FIRE THE RIFLE IF THE CAM PIN IS MISSING. THE RIFLE WILL STILL FIRE WITHOUT THE CAM PIN AND WILL EXPLODE.

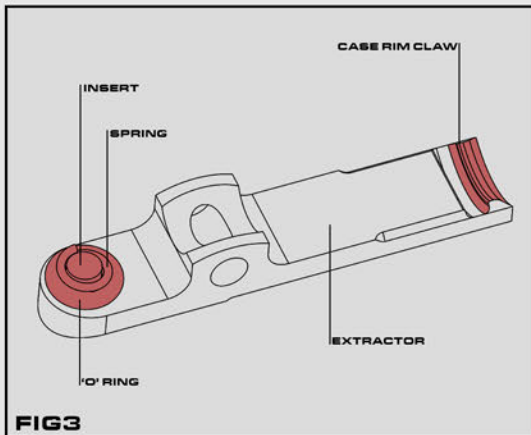

FIG3

4. WE DO NOT RECOMMEND REMOVAL OF THE EJECTOR, HOWEVER, IT SHOULD BE FUNCTION CHECKED WHENEVER THE BOLT IS REMOVED.

OIL THE EJECTOR THEN TAKE A DUMMY OR FIRED CASE AND PLACE IT UNDER THE LIP OF THE EXTRACTOR, THEN ROTATE THE CASE AGAINST THE EJECTOR & BOLT FACE. REPEAT THE PROCESS TO MAKE SURE THAT THE SPRING IS FUNCTIONING, FIG4. WE RECOMMEND BREAKFREE CLP FOR OILING SMALL AREAS OF THE BOLT.

CLEAN UP ANY EXCESS OIL WITH A CLOTH.

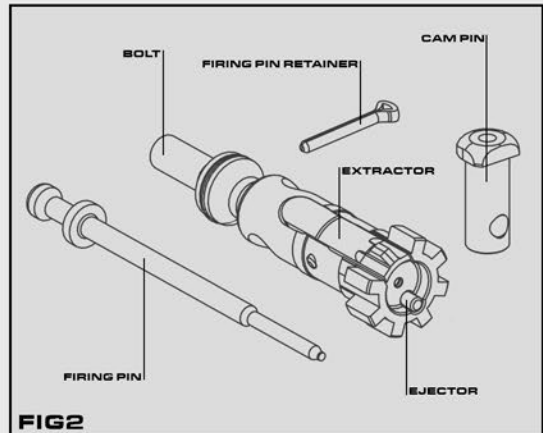

FIG2

3. CAREFULLY INSPECT THE EXTRACTOR AND EXTRACTOR SPRING, CHECK THE EXTRACTOR FOR DAMAGE IF THE EDGE THAT ENGAGES WITH THE CARTRIDGE RIM IS CHIPPED IT SHOULD BE REPLACED. CHECK THAT THE SPRING, INSERT & 'O' RING ARE PRESENT AND ASSEMBLED CORRECTLY. CLEAN OFF ANY FOULING FROM ALL PARTS, FIG3.

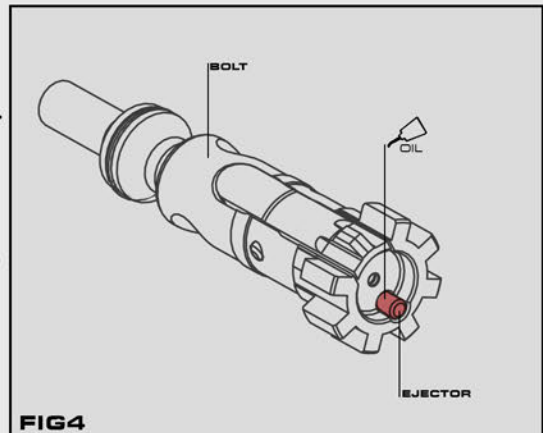

FIG4

LOWER RECEIVER

1. CLEAN ALL AREAS OF THE LOWER RECEIVER WITH A SOFT BRISTLED BRUSH, Q-TIPS AND CLOTH.

ATTENTION

DO NOT USE ABRASIVES OR WIRE BRISTLED BRUSHES, AS THEY WILL DAMAGE THE SURFACE FINISH.

2. WIPE DIRT AWAY FROM THE TRIGGER MECHANISM, USE HIGH PRESSURE AIR IF YOU HAVE IT AVAILABLE, MAKING SURE THAT EYE PROTECTION IS ALWAYS WORN. PAY ATTENTION TO THE BOLT CATCH AREA, TAKEDOWN PINS AND MAG CATCH. REMOVE THE BUFFER AND SPRING AND CLEAN INSIDE THE BUFFER TUBE, WIPE THE BUFFER SPRING CLEAN WITH A CLOTH. A SMALL DECORATORS PAINT BRUSH CAN BE USED TO REMOVE POWDER RESIDUE FROM THE DEEPER AREAS OF THE LOWER RECEIVER.

LUBRICATION

UPPER RECEIVER

THIS RAVEN™ RIFLE FEATURES A UAR™ UPPER RECEIVER THAT HAS A BORE MACHINED WITH AN ULTRA SMOOTH SURFACE. IT SHOULD BE LIGHTLY LUBRICATED USING FROGLUBE™, EITHER APPLIED BY BRUSH OR CLOTH. ONLY A LIGHT FILM OF LUBRICANT IS REQUIRED.

LUBRICATE THE INNER BORE, BARREL EXTENSION & CHARGING HANDLE SLOT. LUBRICATE THE FORWARD ASSIST AREA WITH A FEW DROPS OF LIQUID AND CHECK FUNCTION.

LUBRICATE THE CHARGING HANDLE BODY, LATCH AND SPRINGS, CHECK FUNCTION.

LUBRICATE THE E-BCG™ BOLT CARRIER, BOTH THE BORE AND EXTERIOR SURFACE SHOULD BE LUBRICATED, USE ONLY FROGLUBE™, OTHER LUBRICATION PRODUCTS HAVE BEEN KNOWN TO DISCOLOR THE NIB COATING, PAY ATTENTION TO THE AREAS HIGHLIGHTED IN FIG 1.

ATTENTION

A SLIGHT DISCOLORATION TO THE NIB COATING IS NORMAL OVER TIME.

LUBRICATE THE CAM PIN AREA, BORE & EXTERIOR RUNNING SURFACES. MAKE SURE THE GAS KEY HOLE IS DRY WITH A Q-TIP AND APPLY A DROP OF LUBRICANT TO THE END.

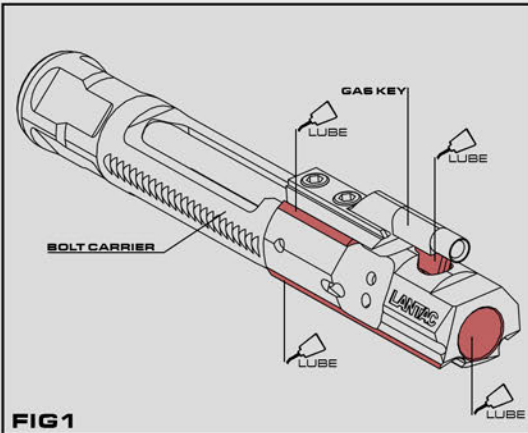

FIG 1

LUBRICATE THE FIRING PIN, BOLT, INCLUDING THE BOLT LUGS AND EXTRACTOR.

LOWER RECEIVER

LIGHTLY LUBRICATE INSIDE THE LOWER RECEIVER, USE A THIN BRUSH AND APPLY FROGLUBE™ PASTE TO THE INSIDE OF THE BUFFER TUBE AND BUFFER SPRING. LUBRICATE ALL MOVING PARTS INCLUDING TAKEDOWN AND PIVOT PINS. PAY ATTENTION TO THE BOLT CATCH AND MAGAZINE CATCH MECHANISMS.

REASSEMBLY

FOLLOW THIS GUIDE TO REASSEMBLE YOUR RIFLE. YOU CAN ALSO REFERENCE THE EXPLODED DIAGRAMS SECTION OF THIS BOOKLET FOR FURTHER INFORMATION.

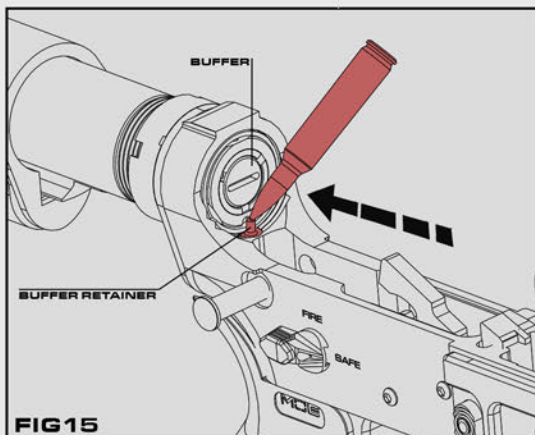

FIG15

2. REASSEMBLE THE EXTRACTOR AND BOLT. MAKE SURE THAT THE EXTRACTOR SPRING ASSEMBLY IS ASSEMBLED CORRECTLY. THE SPRING CAN BE SEATED INTO THE EXTRACTOR BY PUSHING DOWN ON IT WITH A PUNCH OR BULLET TIP, FIG2. IT IS WIDER AT ITS BASE. AFTER THE SPRING AND INSERT ARE IN PLACE, MOUNT THE 'O' RING OVER THE SPRING.

1. REASSEMBLE THE ACTION SPRING AND BUFFER INTO THE BUFFER TUBE. DEPRESS THE BUFFER RETAINER AND PUSH THE SPRING AND BUFFER INTO THE BUFFER TUBE, THEN RELEASE THE DETENT, FIG1.

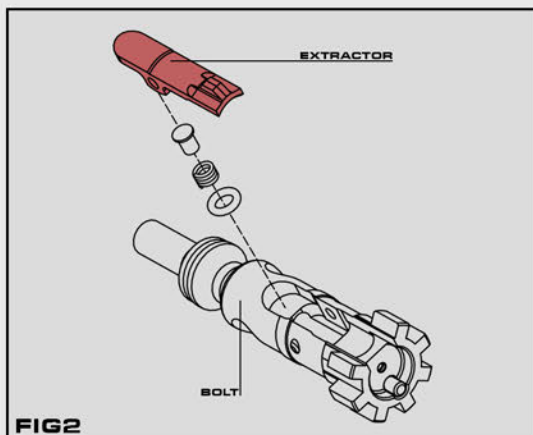

FIG2

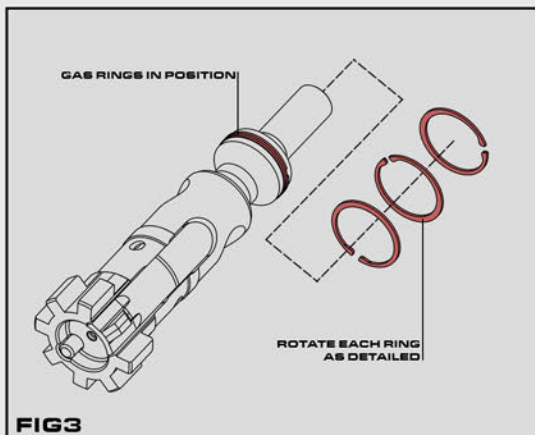

FIG3

4. SLIDE THE BOLT INTO THE CARRIER AND TWIST INTO POSITION, ALIGN THE CAM PIN HOLE WITH THE SLOT IN THE CARRIER. INSERT THE CAM PIN WITH THE FLAT FACE POINTING TOWARDS THE GAS KEY. THEN ROTATE THE CAM PIN 90° SO THAT THE FLAT FACE POINTS TOWARDS THE BOLT LUGS. IF THE CAM PIN WILL NOT FIT THEN ROTATE THE BOLT 180° AND TRY AGAIN, FIG4.

3. MAKE SURE THE GAS RINGS IN THE REAR SECTION OF THE BOLT ARE STAGGERED, PLACE THEM AT 120° APART. THIS WILL CREATE THE BEST GAS SEAL. USE A SHARP POINTED TOOL TO PUSH THE RINGS AROUND, FIG3.

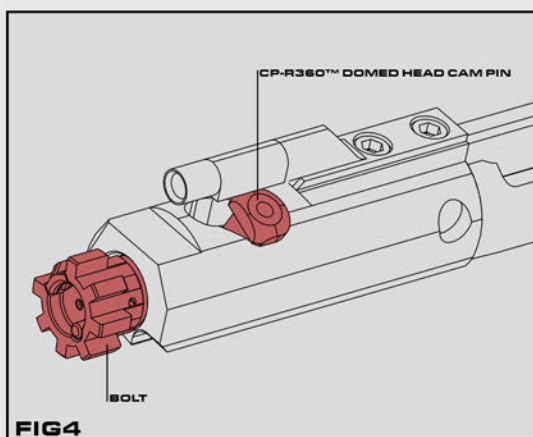

FIG4

!WARNING

THE CAM PIN MUST BE INSTALLED INTO THE BOLT AND CARRIER GROUP. IF IT IS NOT INSTALLED THEN THE RIFLE CAN STILL FIRE AND WILL EXPLODE. THIS COULD CAUSE SEVERE INJURY OR DEATH.

5. SLIDE IN THE FIRING PIN FROM THE REAR OF THE CARRIER THEN PULL THE BOLT STRAIGHT OUT UNTIL IT STOPS, MAKE SURE THE FIRING PIN IS FULLY FORWARD AND THEN INSERT THE RETAINING PIN. TEST THAT THE PIN IS CAPTURED BY GENTLY TAPPING THE BASE OF THE CARRIER ON A PROTECTED SURFACE. FIG5 & FIG6.

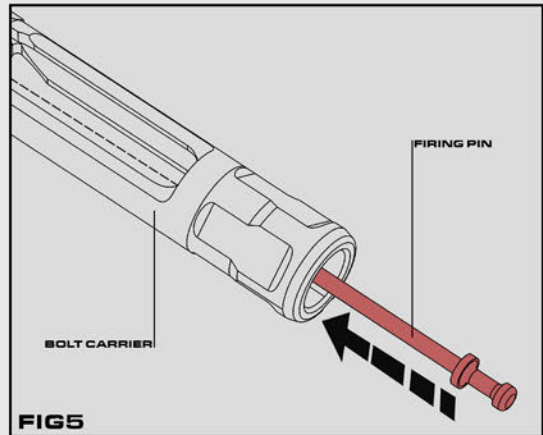

FIG5

!WARNING

DO NOT SWAP BOLTS FROM ONE RIFLE TO ANOTHER WITHOUT CHECKING HEADSPACE FIRST. IF THE BOLT IS OUT OF HEADSPACE THEN FIRING IT COULD RESULT IN SEVERE INJURY OR DEATH. CHECK HEADSPACE WITH A GO & NO-GO GAUGE, IF THE BOLT CLOSSES ON A NO-GO GAUGE DO NOT FIRE THE RIFLE. TAKE IT TO A QUALIFIED GUNSMITH.

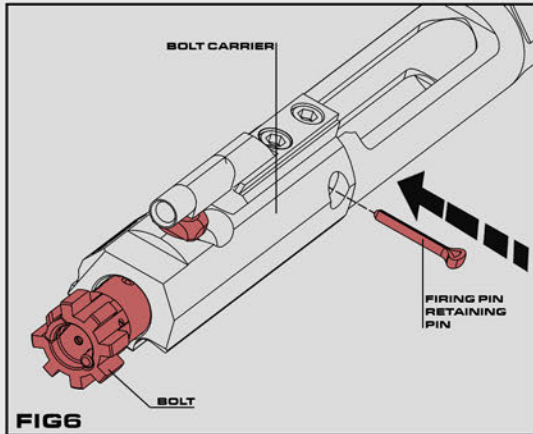

FIG6

6. NEXT SLIDE THE CHARGING HANDLE INTO THE UPPER RECEIVER, MAKE SURE THE LUGS SLIDE DOWN INTO THE HOLE AND THEN SLIDE THE CHARGING HANDLE FORWARD WITH THE LUGS REGISTERED IN THE SLOT, ONLY SLIDE THE CHARGING HANDLE HALF WAY IN.

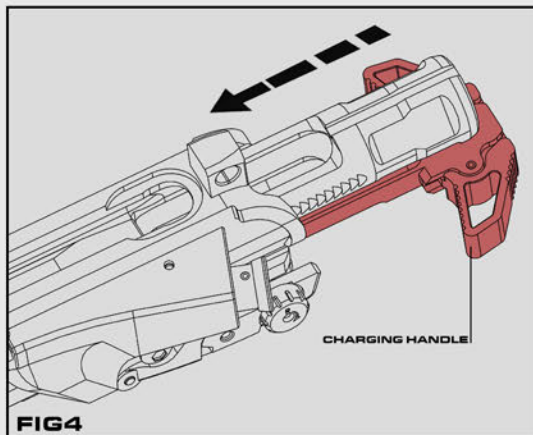

FIG4

LOWER THE COMPLETE BOLT CARRIER GROUP IN THE RECEIVER, MAKING SURE THAT THE GAS KEY IS ALIGNED WITH THE GROOVE IN THE CHARGING HANDLE AND THAT THE BOLT IS FULLY PULLED OUT, SO THAT THE CAM PIN WILL REGISTER WITH THE CHANNEL IN THE RECEIVER. THEN SLIDE THE ENTIRE ASSEMBLY FORWARD UNTIL THE CHARGING HANDLE LATCH LOCKS IN PLACE, FIG7.

!CAUTION

ALWAYS PLACE THE SAFETY SELECTOR IN THE 'SAFE' POSITION BEFORE MATING THE RECEIVERS TOGETHER.

7. PLACE THE TWO RECEIVERS TOGETHER AND CAREFULLY PUSH THROUGH THE PIVOT PIN THEN THE TAKEDOWN PIN. IT MAY BE NECESSARY TO SQUEEZE THE RECEIVERS TOGETHER IN ORDER TO GET THE REAR PIN TO FULLY INSERT, FIG8.

REMEMBER THAT THE PIVOT & TAKEDOWN PINS ARE RETAINED BY SPRUNG LOADED DETENTS AND NOT INTENDED TO BE REMOVED FROM THE RECEIVERS, ATTEMPTING REMOVAL WILL DAMAGE THE RECEIVERS.

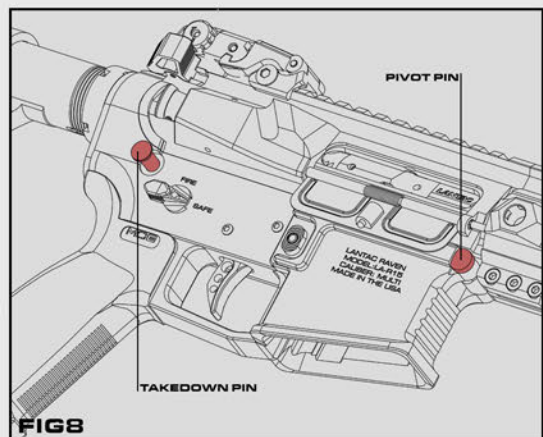

FIG8

RETURNS & WARRANTY

RETURNS

ALL CUSTOM WORK & CUSTOM MANUFACTURED FIREARMS ARE CONSIDERED A FINAL SALE, THEY ARE NOT ELIGIBLE FOR RETURNS OR REFUNDS.

ALL PRODUCTS RETURNED TO LANTAC USA LLC MUST HAVE AN RMA NUMBER, OBTAINED FROM US PRIOR TO SHIPPING OF THE GOODS BY THE CUSTOMER.

SHIPPING COSTS & INSURANCE OF SHIPPED GOODS ARE THE RESPONSIBILITY OF THE CUSTOMER.

PRODUCTS ORDERED IN ERROR CAN BE RETURNED TO LANTAC USA LLC WITHIN 30 DAYS OF RECEIPT OF ORDER.

RETURNED PRODUCTS MUST BE UNUSED, NEW, AND IN THE ORIGINAL PACKAGING.

RETURN FREIGHT MUST BE PRE-PAID.

A 10% RESTOCKING FEE WILL BE DEDUCTED.

LANTAC USA LLC WILL NOT ASSUME RESPONSIBILITY FOR UNAUTHORISED MODIFICATION, ADJUSTMENT OR USE OF NON AUTHORIZED PARTS.

THIS RAVEN™ RIFLE IS MANUFACTURED TO THE HIGHEST QUALITY STANDARDS AND WILL PERFORM AS DESIGNED IF USED ACCORDING TO THESE INSTRUCTIONS. DO NOT MODIFY OR ALTER ITS COMPONENTS. DO NOT MODIFY THE WAY IT FUNCTIONS.

DO NOT FIT SUB STANDARD THIRD PARTY ACCESSORIES.

ENSURE THAT ONLY LANTAC SPARE PARTS ARE USED AND THAT WORK IS CARRIED OUT BY A COMPETENT AND TRUSTED GUNSMITH WHO IS QUALIFIED TO WORK ON THIS TYPE OF FIREARM PLATFORM.

WARRANTY

YOUR RAVEN™ RIFLE IS WARRANTIED AGAINST DEFECTS IN MATERIALS AND WORKMANSHIP. IF YOUR RIFLE SHOWS EVIDENCE OF DEFECTS IT WILL BE REPAIRED OR REPLACED BY LANTAC USA LLC AS QUICKLY AND EFFICIENTLY AS POSSIBLE, WITH THE MINIMUM COST TO YOU THE CUSTOMER.

LANTAC USA LLC DOES NOT WARRANT DAMAGE CAUSED TO OUR PRODUCTS BY IMPROPER USE OR MODIFICATION, OR INCORRECT INSTALLATION OF OTHER MANUFACTURERS PRODUCTS & ACCESSORIES.

!WARNING

HEALTH & ENVIRONMENTAL DANGER.

DISCHARGING FIREARMS IN POORLY VENTILATED AREAS, CLEANING FIREARMS OR HANDLING DIRTY FIREARMS & AMMUNITION MAY RESULT IN EXPOSURE TO LEAD AND OTHER SUBSTANCES KNOWN TO CAUSE BIRTH DEFECTS, REPRODUCTIVE HARM, CANCER, AND OTHER SERIOUS PHYSICAL INJURY. MAKE SURE YOU HAVE ADEQUATE VENTILATION AT ALL TIMES. WASH YOUR HANDS IMMEDIATELY AND THOROUGHLY AFTER EXPOSURE.

WEAR SHOOTING GLOVES TO LIMIT SKIN EXPOSURE AND AVOID TOUCHING YOUR FACE WITH CONTAMINATED HANDS.

THIS INSTRUCTION MANUAL SHOULD ACOMPANY THIS FIREARM AT ALL TIMES, IF YOU SELL, LEND OR GIVE THIS RIFLE TO ANOTHER PERSON MAKE SURE THAT THIS MANUAL IS INCLUDED.

IF YOU LOSE THIS INSTRUCTION MANUAL, IT BECOMES DAMAGED OR DESTROYED YOU CAN OBTAIN A REPLACEMENT COPY BY CALLING LANTAC USA LLC ON:

1-817-420-6011

OR WRITE TO US AT:

LANTAC USA LLC
1300 FORUM WAY S.
SUITE B
FORT WORTH
TEXAS
71640

PLEASE INCLUDE YOUR FIREARM MODEL, SERIAL NUMBER AND YOUR ADDRESS.

PARTS INFORMATION

BOLT CARRIER GROUP

THIS RAVEN™ RIFLE FEATURES A LANTAC E-BCG™ ENHANCED BOLT CARRIER GROUP. THE E-BCG™ IS PRECISION MACHINED AND COATED WITH A NIB, ELECTROLESS NICKLE BORON COATING, MAKING IT EXTREMELY HARD AND SMOOTH. THE PRIMARY GAS PORT IS SHROUDED WHILE THE OTHERS HAVE BEEN ENLARGED AND ANGLED FORWARDS. THE FLARED TAIL OF THE CARRIER ASSISTS IN BALANCE AND THE CP-R360™ CAM PIN WORKS WITH THE UAR™ UPPER RECEIVER TO REDUCE FRICTION AND WEAR. THESE FEATURES COMBINE TO DELIVER A SYSTEM THAT OFFERS REDUCED RECOIL, FLATTER SHOOTING WITH ENHANCED ACCURACY, THROUGH INCREASED 'LOCK TIME' AND BALANCE. FOR CLEANING AND MAINTENANCE INSTRUCTIONS PLEASE SEE PAGE 17.

E-BCG™ ENHANCED BOLT CARRIER GROUP SMOOTHCAM PORT FORWARD

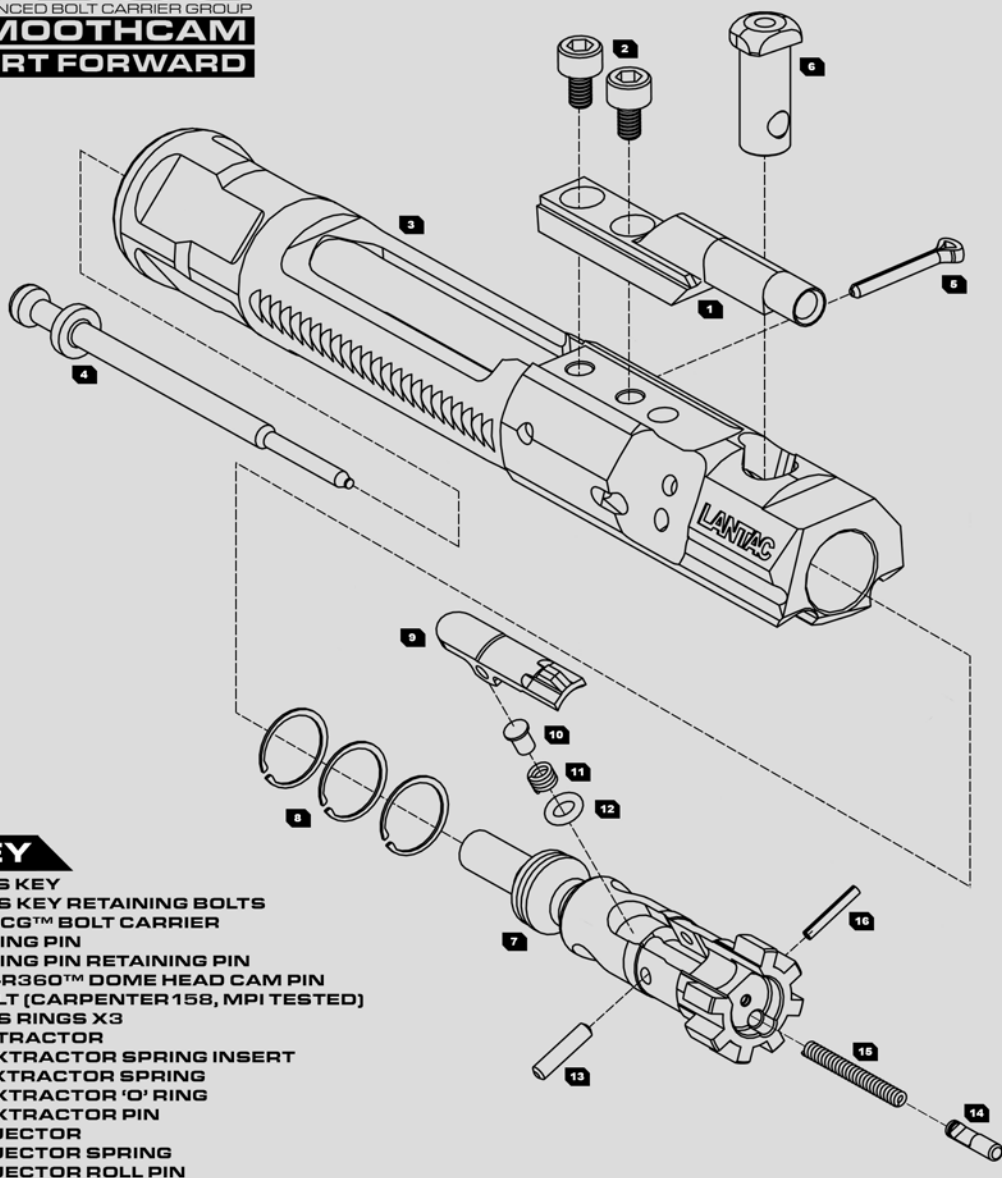

KEY

1. GAS KEY
2. GAS KEY RETAINING BOLTS
3. E-BCG™ BOLT CARRIER
4. FIRING PIN
5. FIRING PIN RETAINING PIN
6. CP-R360™ DOME HEAD CAM PIN
7. BOLT (CARPENTER 158, MPI TESTED)
8. GAS RINGS X3
9. EXTRACTOR
10. EXTRACTOR SPRING INSERT
11. EXTRACTOR SPRING
12. EXTRACTOR 'O' RING
13. EXTRACTOR PIN
14. EJECTOR
15. EJECTOR SPRING
16. EJECTOR ROLL PIN

PARTS INFORMATION

ABS™ ADJUSTABLE BUFFER SYSTEM

THIS RAVEN™ RIFLE FEATURES AN ABS™ ADJUSTABLE BUFFER SYSTEM THAT ALLOWS THE USER TO ALTER THE PRELOAD OF THE ACTION SPRING. THE BUFFER SYSTEM CAN BE TUNED TO PRODUCE VIRTUALLY NO CARRIER GROUP RECOIL, MAKING THE RIFLE VERY EASY TO KEEP ON TARGET FROM SHOT TO SHOT. SEE PAGE 09 'ABS BUFFER' FOR FURTHER INFORMATION ON ADJUSTMENT.

LANTAC ABS™

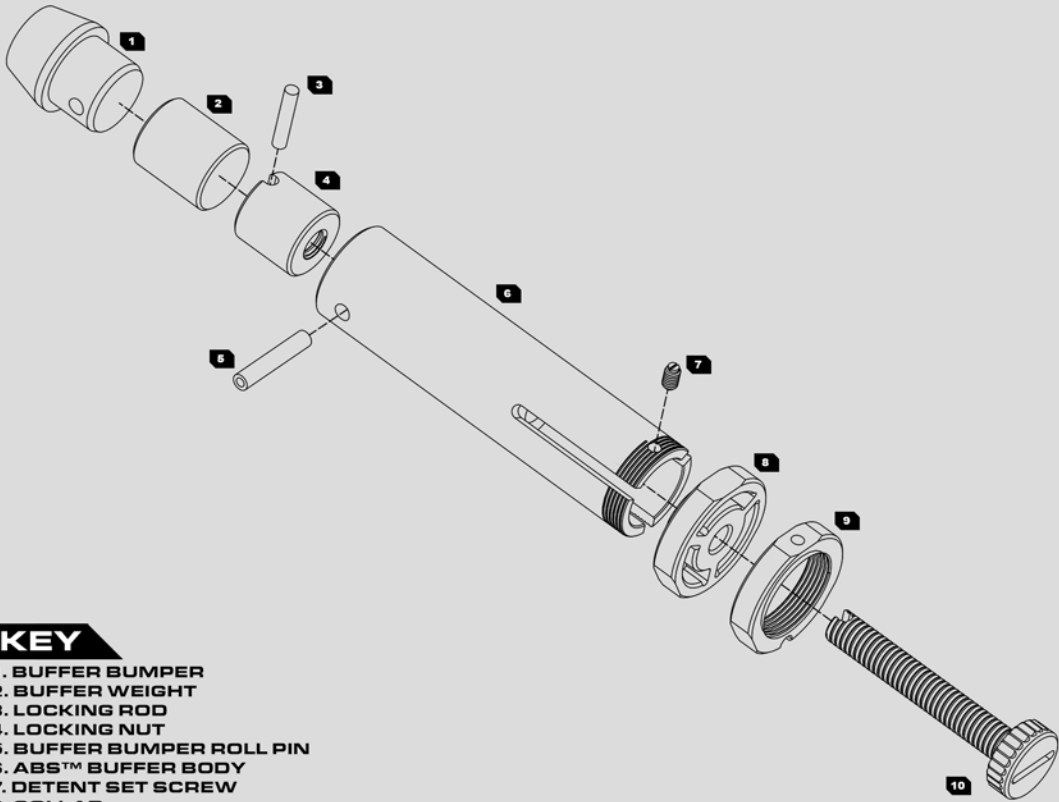

KEY

1. BUFFER BUMPER
2. BUFFER WEIGHT
3. LOCKING ROD
4. LOCKING NUT
5. BUFFER BUMPER ROLL PIN
6. ABS™ BUFFER BODY
7. DETENT SET SCREW
8. COLLAR
9. HEAD NUT
10. PRESSURE ADJUSTMENT SCREW

PARTS INFORMATION

UPPER RECEIVER

THIS RAVEN™ RIFLE FEATURES AN AMBIDEXTROUS CHARGING HANDLE AND SAFETY SELECTOR, MAGPUL MBUS SIGHTS FRONT & REAR, SPADA-S™ LOW PROFILE FREE FLOAT HANDGUARD, DGN556B DRAGON™ MUZZLE BRAKE & INTERMEDIATE GAS SYSTEM. ULTRA SMOOTH RECEIVER BORE AND RADIUSED CAM PIN SLOT. METICULOUSLY ASSEMBLED AT OUR FACILITY IN FORT WORTH, TEXAS, BY SKILLED GUNSMITHS, THE RAVEN™ RIFLE IS THE COMBINATION OF SOME OF THE MOST ADVANCED COMPONENTS ON THE MARKET TODAY.

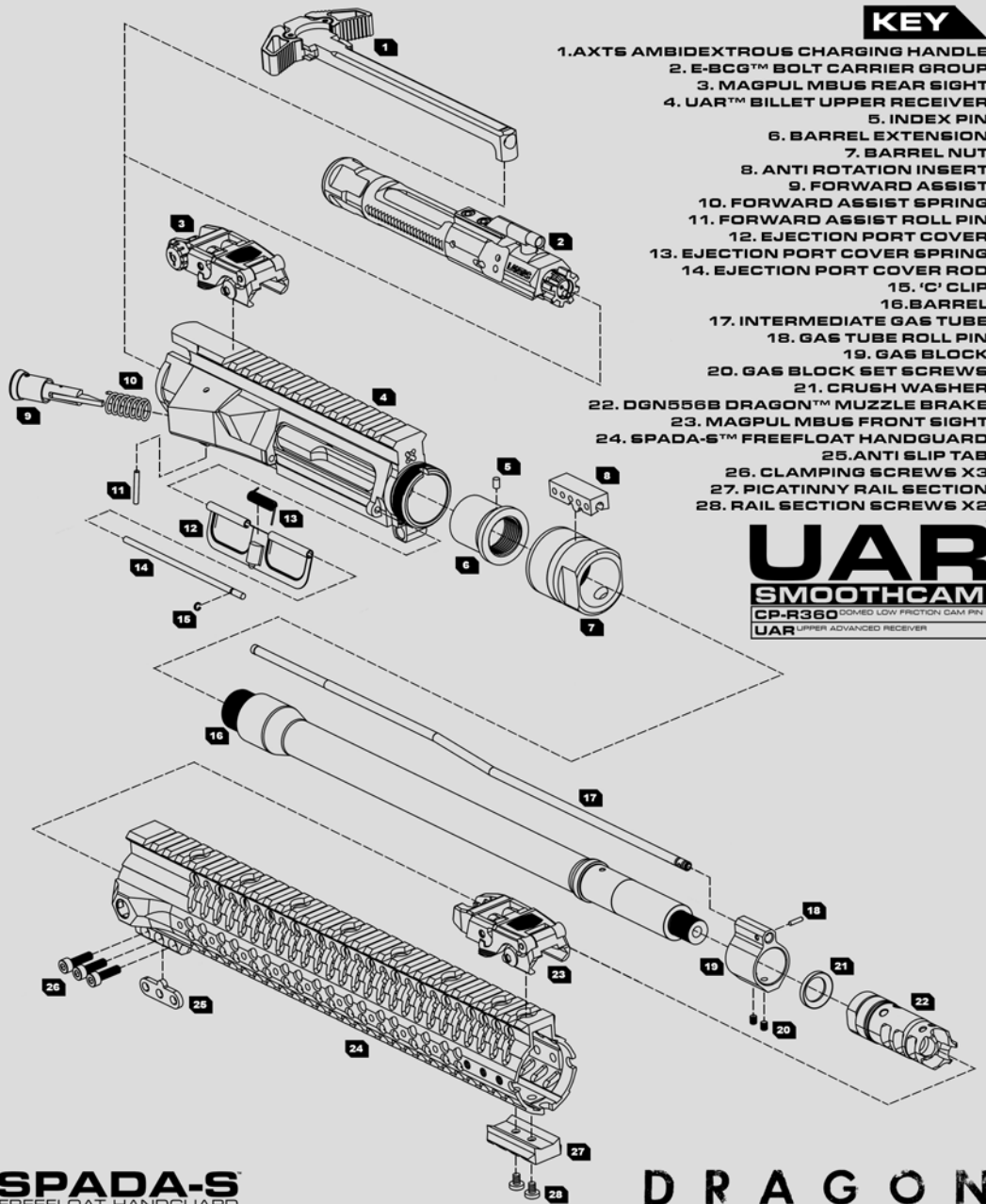

PARTS INFORMATION

LOWER RECEIVER

PRECISION MACHINED FROM 7075T6 BILLET ALUMINUM & TYPE 3 HARDCOAT ANODIZED RECEIVER, WITH FLARED MAGWELL FOR EASIER LOADING & A 3.5LB SINGLE STAGE TRIGGER FITTED AS STANDARD. MAGPUL MOE+ GRIP, CTR STOCK & .70" RECOIL PAD INCLUDED.

LANTAC
E-CT1
TRIGGER

KEY

1. MAGPUL CTR STOCK & .70" RECOIL PAD.
2. BUFFER TUBE
3. BUFFER SPRING
4. ABS™ BUFFER
5. CASTLE NUT
6. ANTI ROTATION PLATE
7. BUFFER DETENT SPRING
8. BUFFER DETENT
9. TAKEDOWN PIN SPRING
10. TAKEDOWN PIN DETENT
11. TAKEDOWN PIN
12. PIVOT PIN
13. PIVOT PIN SPRING
14. PIVOT PIN DETENT
15. 7075T6 BILLET RECEIVER
16. CMC E-CT™ TRIGGER
17. TRIGGER PIN SCREWS
18. TRIGGER PINS
19. MAGAZINE CATCH
20. MAGAZINE CATCH SPRING
21. MAGAZINE CATCH BUTTON
22. MAGPUL MOE+ GRIP
23. GRIP SCREW WASHER
24. GRIP SCREW
25. AXTS SAFETY SELECTOR
26. SAFETY DETENT
27. SAFETY DETENT SPRING
28. BOLT CATCH
29. BOLT CATCH DETENT
30. BOLT CATCH SPRING
31. BOLT CATCH ROLL PIN

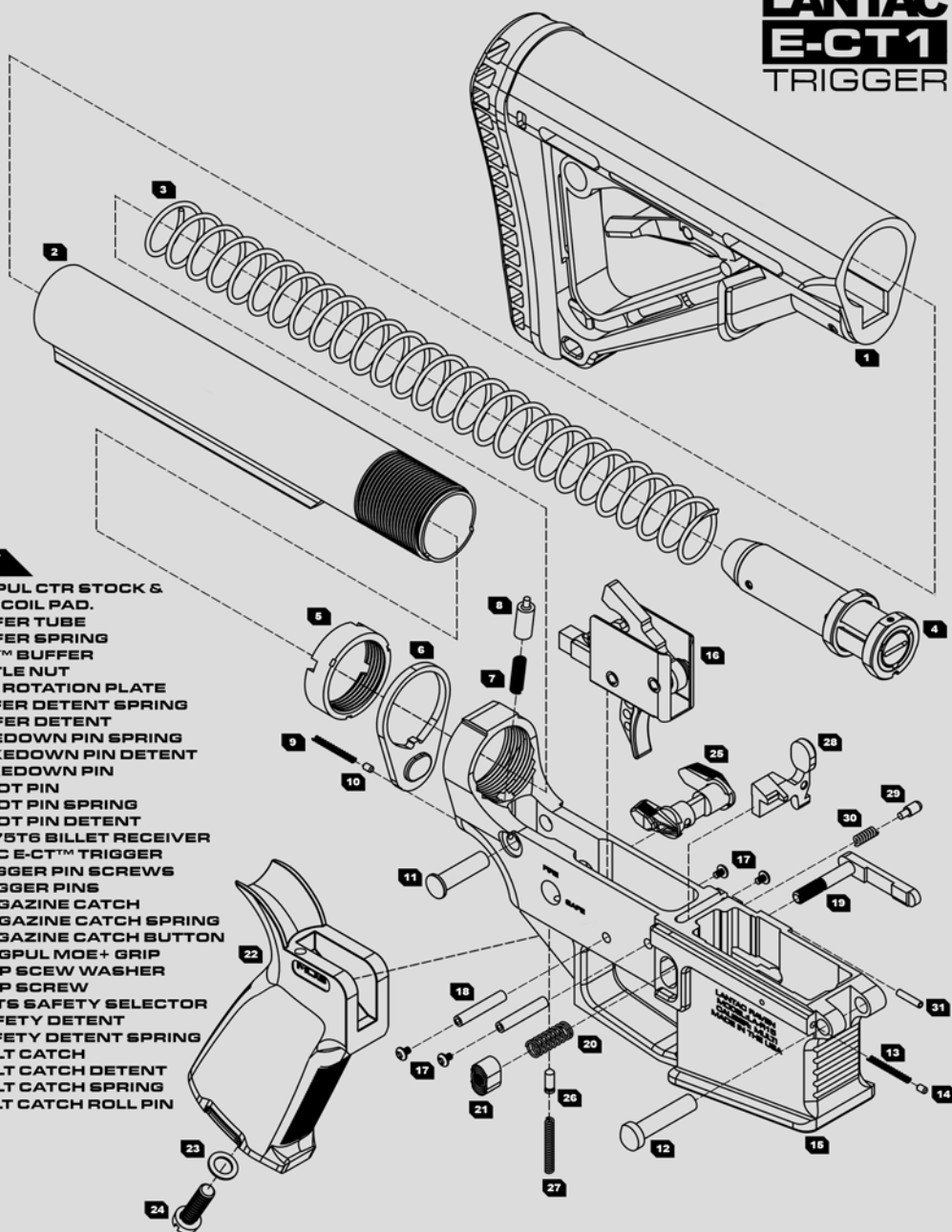

RECEIVER ASSEMBLIES

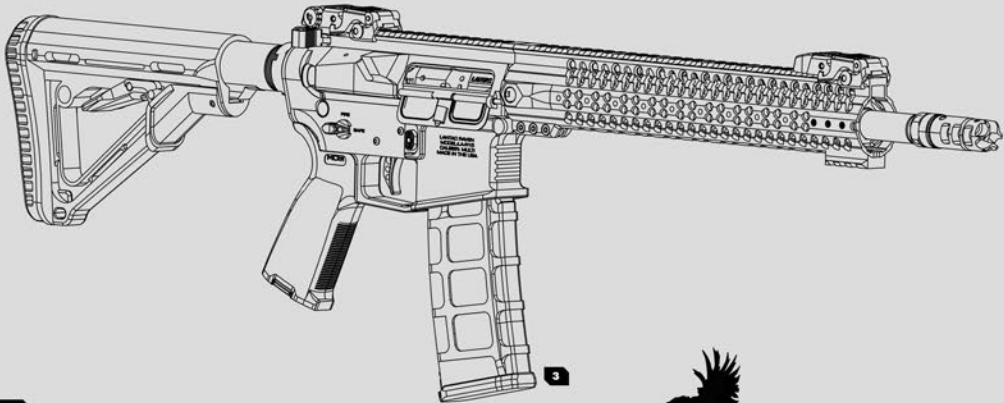
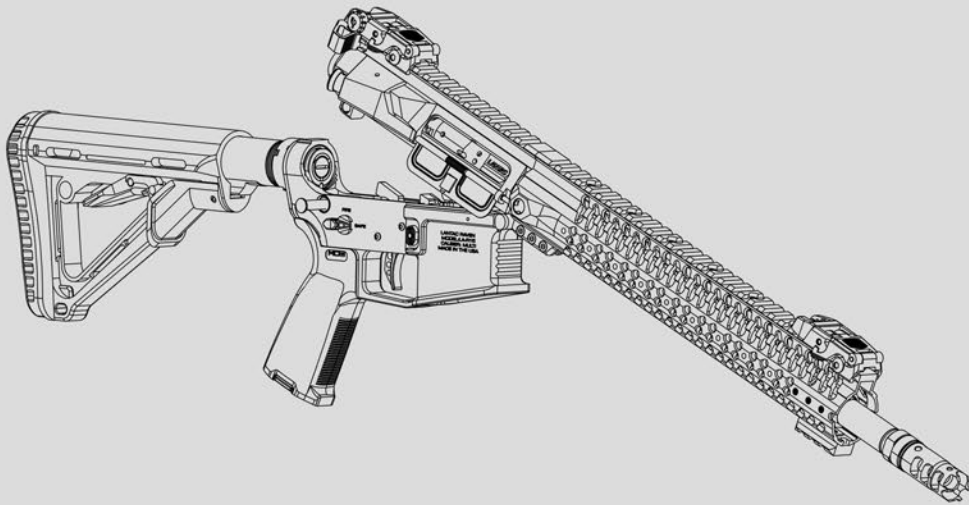
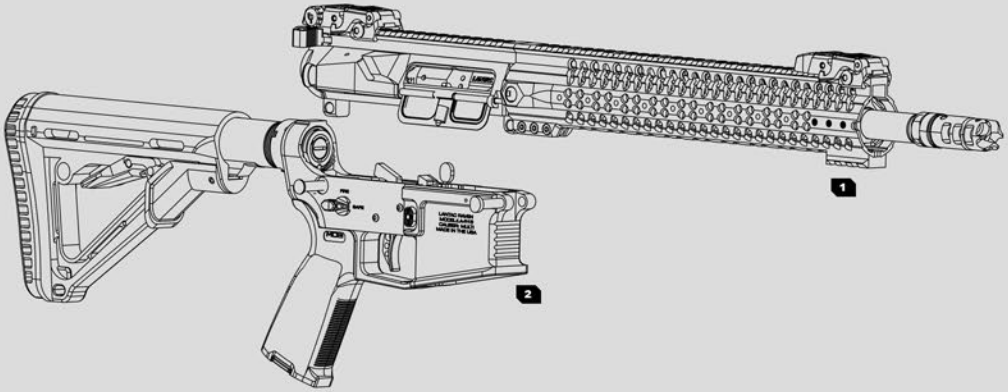

KEY

- 1. 7075T6 BILLET UPPER RECEIVER ASSEMBLY
- 2. 7075T6 BILLET LOWER RECEIVER ASSEMBLY
- 3. MAGPUL PMAG 30RND MAGAZINE*



*SEE RESTRICTIONS

LANTAC

817-420-6011
WWW.LANTAC-USA.COM

27

RIFLE RECORD SHEET

LANTAC USA LLC RAVEN™ RIFLE

MODEL _____

SERIAL NUMBER _____

CALIBER _____

PURCHASED FROM _____

PURCHASE DATE _____

PURCHASE PRICE _____

NOTES



LANTAC™

WWW.LANTAC-USA.COM

1300 FORUM WAY : FORT WORTH: TEXAS: 76140

1.817.420.6011

V1.00/2016 COPYRIGHT 2016 ALL RIGHTS RESERVED LANTAC USA LLC. PATENTS GRANTED & PENDING.



MADE IN THE USA

